



Activity Report 2016

Project-Team APICS

Analysis and Problems of Inverse type in
Control and Signal processing

RESEARCH CENTER
Sophia Antipolis - Méditerranée

THEME
**Optimization and control of dynamic
systems**

Table of contents

1. Members	1
2. Overall Objectives	2
3. Research Program	2
3.1. Introduction	2
3.2. Range of inverse problems	4
3.2.1. Elliptic partial differential equations (PDE)	4
3.2.2. Systems, transfer and scattering	6
3.3. Approximation	7
3.3.1. Best analytic approximation	7
3.3.2. Best meromorphic and rational approximation	9
3.3.2.1. Scalar meromorphic and rational approximation	9
3.3.2.2. Matrix-valued rational approximation	10
3.3.3. Behavior of poles of meromorphic approximants	11
3.4. Software tools of the team	11
3.4.1. DEDALE-HF	12
3.4.2. FindSources3D	12
3.4.3. PRESTO-HF	12
3.4.4. RARL2	13
3.4.5. Sollya	14
4. Application Domains	14
4.1. Introduction	14
4.2. Inverse magnetization problems	14
4.3. Inverse source problems in EEG	15
4.4. Identification and design of microwave devices	15
5. New Results	18
5.1. Inverse problems for Poisson-Laplace equations	18
5.1.1. Inverse magnetization issues in the thin-plate framework	19
5.1.2. Inverse magnetization issues from sparse spherical data	20
5.1.3. Surface distributed magnetizations and vector fields decomposition	21
5.1.4. Decomposition of the geomagnetic field	22
5.1.5. Inverse problems in medical imaging	22
5.2. Matching problems and their applications	23
5.2.1. Approach based on interpolation	24
5.2.2. Uniform matching and global optimality considerations	25
5.3. Sensitivities of Electrical Parameters with respect to physical parameters	25
5.4. Stability of amplifiers	25
5.5. Tools for numerically guaranteed computations	26
5.6. Asymptotics of weighted Bergman polynomials	26
6. Bilateral Contracts and Grants with Industry	26
6.1. Contract CNES-Inria-XLIM	26
6.2. Contract CNES-Inria-UPV/EHU	27
6.3. Contract BESA GmbH-Inria	27
6.4. Flextronics	27
7. Partnerships and Cooperations	27
7.1. Regional Initiatives	27
7.2. National Initiatives	27
7.2.1. ANR COCORAM	27
7.2.2. ANR MagLune	28
7.3. European Initiatives	28

7.4.	International Initiatives	28
7.4.1.	Inria Associate Teams Not Involved in an Inria International Labs	28
7.4.2.	Inria International Partners	28
7.5.	International Research Visitors	29
7.6.	List of international and industrial partners	29
8.	Dissemination	29
8.1.	Promoting Scientific Activities	29
8.1.1.	Scientific Events Organisation	30
8.1.2.	Scientific Events Selection	30
8.1.3.	Journal	30
8.1.3.1.	Member of the Editorial Boards	30
8.1.3.2.	Reviewer - Reviewing Activities	30
8.1.4.	Invited Talks	31
8.1.5.	Scientific Expertise	31
8.1.6.	Research Administration	31
8.2.	Teaching - Supervision - Juries	31
8.2.1.	Teaching	31
8.2.2.	Supervision	31
8.2.3.	Juries	32
8.3.	Popularization	32
9.	Bibliography	32

Project-Team APICS

Creation of the Project-Team: 2005 January 01

Keywords:

Computer Science and Digital Science:

- 6.1.1. - Continuous Modeling (PDE, ODE)
- 6.2. - Scientific Computing, Numerical Analysis & Optimization
 - 6.2.1. - Numerical analysis of PDE and ODE
 - 6.2.5. - Numerical Linear Algebra
 - 6.2.6. - Optimization
- 6.3.1. - Inverse problems
- 6.3.3. - Data processing
- 6.3.4. - Model reduction
- 6.4. - Automatic control
 - 6.4.4. - Stability and Stabilization
- 7.3. - Optimization
- 7.5. - Geometry, Topology
- 7.6. - Computer Algebra

Other Research Topics and Application Domains:

- 2.6. - Biological and medical imaging
 - 2.6.1. - Brain imaging
- 3. - Environment and planet
 - 3.3. - Geosciences
 - 3.3.1. - Earth and subsoil
- 5.2. - Design and manufacturing
 - 5.2.4. - Aerospace
- 5.4. - Microelectronics
- 6.2.2. - Radio technology
- 6.2.3. - Satellite technology

1. Members

Research Scientists

Laurent Baratchart [Inria, Senior Researcher, Team Leader, HDR]
Sylvain Chevillard [Inria, Researcher]
Juliette Leblond [Inria, Senior Researcher, HDR]
Martine Olivi [Inria, Researcher, HDR]
Fabien Seyfert [Inria, Researcher]

Engineer

Nicolas Schnitzler [SED Inria, part-time in the team, until July 2016]

PhD Students

Gibin Bose [UNSA (Univ. Nice - Sophia Antipolis), from November 2016]
Matthias Caenepeel [Vrije Universiteit Brussel (VUB), until September 2016]

Sebastien Fueyo [Inria, from October 2016]

David Martinez Martinez [Inria, Univ. Limoges]

Konstantinos Mavreas [Inria, UNSA - ED STIC, granted by MESR]

Christos Papageorgakis [Inria, UNSA - ED STIC, granted by BESA GmbH and BDO PACA; part time with the team Athena]

Dmitry Ponomarev [Inria, UNSA - EDSTIC, granted by MESR, Inria, CNES, until June 2016]

Visiting Scientist

Jean-Paul Marmorat [Centre de Mathématiques Appliquées (CMA), École des Mines ParisTech]

Administrative Assistants

Marie-Line Meirinho [Inria, part-time in the team, from September 2016]

Stéphanie Sorres [Inria, part-time in the team, until August 2016]

2. Overall Objectives

2.1. Research Themes

The team develops constructive, function-theoretic approaches to inverse problems arising in modeling and design, in particular for electro-magnetic systems as well as in the analysis of certain classes of signals.

Data typically consist of measurements or desired behaviors. The general thread is to approximate them by families of solutions to the equations governing the underlying system. This leads us to consider various interpolation and approximation problems in classes of rational and meromorphic functions, harmonic gradients, or solutions to more general elliptic partial differential equations (PDE), in connection with inverse potential problems. A recurring difficulty is to control the singularities of the approximants.

The mathematical tools pertain to complex and harmonic analysis, approximation theory, potential theory, system theory, differential topology, optimization and computer algebra. Targeted applications include:

- identification and synthesis of analog microwave devices (filters, amplifiers),
- non-destructive control from field measurements in medical engineering (source recovery in magneto/electro-encephalography), and paleomagnetism (determining the magnetization of rock samples).

In each case, the endeavor is to develop algorithms resulting in dedicated software.

3. Research Program

3.1. Introduction

Within the extensive field of inverse problems, much of the research by Apics deals with reconstructing solutions of classical elliptic PDEs from their boundary behavior. Perhaps the simplest example lies with harmonic identification of a stable linear dynamical system: the transfer-function f can be evaluated at a point $i\omega$ of the imaginary axis from the response to a periodic input at frequency ω . Since f is holomorphic in the right half-plane, it satisfies there the Cauchy-Riemann equation $\bar{\partial}f = 0$, and recovering f amounts to solve a Dirichlet problem which can be done in principle using, *e.g.* the Cauchy formula.

Practice is not nearly as simple, for f is only measured pointwise in the pass-band of the system which makes the problem ill-posed [70]. Moreover, the transfer function is usually sought in specific form, displaying the necessary physical parameters for control and design. For instance if f is rational of degree n , then $\bar{\partial}f = \sum_1^n a_j \delta_{z_j}$ where the z_j are its poles and δ_{z_j} is a Dirac unit mass at z_j . Thus, to find the domain of holomorphy (*i.e.* to locate the z_j) amounts to solve a (degenerate) free-boundary inverse problem, this time on the left half-plane. To address such questions, the team has developed a two-step approach as follows.

Step 1: To determine a complete model, that is, one which is defined at every frequency, in a sufficiently versatile function class (*e.g.* Hardy spaces). This ill-posed issue requires regularization, for instance constraints on the behavior at non-measured frequencies.

Step 2: To compute a reduced order model. This typically consists of rational approximation of the complete model obtained in step 1, or phase-shift thereof to account for delays. We emphasize that deriving a complete model in step 1 is crucial to achieve stability of the reduced model in step 2.

Step 1 relates to extremal problems and analytic operator theory, see Section 3.3.1. Step 2 involves optimization, and some Schur analysis to parametrize transfer matrices of given Mc-Millan degree when dealing with systems having several inputs and outputs, see Section 3.3.2.2. It also makes contact with the topology of rational functions, in particular to count critical points and to derive bounds, see Section 3.3.2. Step 2 raises further issues in approximation theory regarding the rate of convergence and the extent to which singularities of the approximant (*i.e.* its poles) tend to singularities of the approximated function; this is where logarithmic potential theory becomes instrumental, see Section 3.3.3.

Applying a realization procedure to the result of step 2 yields an identification procedure from incomplete frequency data which was first demonstrated in [76] to tune resonant microwave filters. Harmonic identification of nonlinear systems around a stable equilibrium can also be envisaged by combining the previous steps with exact linearization techniques from [33].

A similar path can be taken to approach design problems in the frequency domain, replacing the measured behavior by some desired behavior. However, describing achievable responses in terms of the design parameters is often cumbersome, and most constructive techniques rely on specific criteria adapted to the physics of the problem. This is especially true of filters, the design of which traditionally appeals to polynomial extremal problems [72], [56]. Apics contributed to this area the use of Zolotarev-like problems for multi-band synthesis, although we presently favor interpolation techniques in which parameters arise in a more transparent manner, see Section 3.2.2.

The previous example of harmonic identification quickly suggests a generalization of itself. Indeed, on identifying \mathbb{C} with \mathbb{R}^2 , holomorphic functions become conjugate-gradients of harmonic functions, so that harmonic identification is, after all, a special case of a classical issue: to recover a harmonic function on a domain from partial knowledge of the Dirichlet-Neumann data; when the portion of boundary where data are not available is itself unknown, we meet a free boundary problem. This framework for 2-D non-destructive control was first advocated in [61] and subsequently received considerable attention. It makes clear how to state similar problems in higher dimensions and for more general operators than the Laplacian, provided solutions are essentially determined by the trace of their gradient on part of the boundary which is the case for elliptic equations¹ [13], [79]. Such questions are particular instances of the so-called inverse potential problem, where a measure μ has to be recovered from the knowledge of the gradient of its potential (*i.e.*, the field) on part of a hypersurface (a curve in 2-D) encompassing the support of μ . For Laplace's operator, potentials are logarithmic in 2-D and Newtonian in higher dimensions. For elliptic operators with non constant coefficients, the potential depends on the form of fundamental solutions and is less manageable because it is no longer of convolution type. Nevertheless it is a useful concept bringing perspective on how problems could be raised and solved, using tools from harmonic analysis.

¹There is a subtle difference here between dimension 2 and higher. Indeed, a function holomorphic on a plane domain is defined by its non-tangential limit on a boundary subset of positive linear measure, but there are non-constant harmonic functions in the 3-D ball, C^1 up to the boundary sphere, yet having vanishing gradient on a subset of positive measure of the sphere. Such a "bad" subset, however, cannot have interior points on the sphere.

Inverse potential problems are severely indeterminate because infinitely many measures within an open set produce the same field outside this set; this phenomenon is called *balayage* [69]. In the two steps approach previously described, we implicitly removed this indeterminacy by requiring in step 1 that the measure be supported on the boundary (because we seek a function holomorphic throughout the right half-space), and by requiring in step 2 that the measure be discrete in the left half-plane (in fact: a sum of point masses $\sum_1^n a_j \delta_{z_j}$). The discreteness assumption also prevails in 3-D inverse source problems, see Section 4.3. Conditions that ensure uniqueness of the solution to the inverse potential problem are part of the so-called regularizing assumptions which are needed in each case to derive efficient algorithms.

To recap, the gist of our approach is to approximate boundary data by (boundary traces of) fields arising from potentials of measures with specific support. This differs from standard approaches to inverse problems, where descent algorithms are applied to integration schemes of the direct problem; in such methods, it is the equation which gets approximated (in fact: discretized).

Along these lines, Apics advocates the use of steps 1 and 2 above, along with some singularity analysis, to approach issues of nondestructive control in 2-D and 3-D [2], [5], [40]. The team is currently engaged in the generalization to inverse source problems for the Laplace equation in 3-D, to be described further in Section 3.2.1. There, holomorphic functions are replaced by harmonic gradients; applications are to EEG/MEG and inverse magnetization problems in geosciences, see Section 4.3.

The approximation-theoretic tools developed by Apics to handle issues mentioned so far are outlined in Section 3.3. In Section 3.2 to come, we describe in more detail which problems are considered and which applications are targeted.

3.2. Range of inverse problems

3.2.1. Elliptic partial differential equations (PDE)

Participants: Laurent Baratchart, Sylvain Chevillard, Juliette Leblond, Konstantinos Mavreas, Christos Papageorgakis, Dmitry Ponomarev.

By standard properties of conjugate differentials, reconstructing Dirichlet-Neumann boundary conditions for a function harmonic in a plane domain, when these conditions are already known on a subset E of the boundary, is equivalent to recover a holomorphic function in the domain from its boundary values on E . This is the problem raised on the half-plane in step 1 of Section 3.1. It makes good sense in holomorphic Hardy spaces where functions are entirely determined by their values on boundary subsets of positive linear measure, which is the framework for Problem (P) that we set up in Section 3.3.1. Such issues naturally arise in nondestructive testing of 2-D (or 3-D cylindrical) materials from partial electrical measurements on the boundary. For instance, the ratio between the tangential and the normal currents (the so-called Robin coefficient) tells one about corrosion of the material. Thus, solving Problem (P) where ψ is chosen to be the response of some uncorroded piece with identical shape yields non destructive testing of a potentially corroded piece of material, part of which is inaccessible to measurements. This was an initial application of holomorphic extremal problems to non-destructive control [54], [57].

Another application by the team deals with non-constant conductivity over a doubly connected domain, the set E being now the outer boundary. Measuring Dirichlet-Neumann data on E , one wants to recover level lines of the solution to a conductivity equation, which is a so-called free boundary inverse problem. For this, given a closed curve inside the domain, we first quantify how constant the solution on this curve. To this effect, we state and solve an analog of Problem (P), where the constraint bears on the real part of the function on the curve (it should be close to a constant there), in a Hardy space of a conjugate Beltrami equation, of which the considered conductivity equation is the compatibility condition (just like the Laplace equation is the compatibility condition of the Cauchy-Riemann system). Subsequently, a descent algorithm on the curve leads one to improve the initial guess. For example, when the domain is regarded as separating the edge of a tokamak's vessel from the plasma (rotational symmetry makes this a 2-D situation), this method can be used to estimate the shape of a plasma subject to magnetic confinement. This was actually carried out in collaboration with CEA (French nuclear agency) and the University of Nice (JAD Lab.), to data from *Tore*

Supra [60]. The procedure is fast because no numerical integration of the underlying PDE is needed, as an explicit basis of solutions to the conjugate Beltrami equation in terms of Bessel functions was found in this case. Generalizing this approach in a more systematic manner to free boundary problems of Bernoulli type, using descent algorithms based on shape-gradient for such approximation-theoretic criteria, is an interesting prospect now under study in the team..

The piece of work we just mentioned requires defining and studying Hardy spaces of the conjugate-Beltrami equation, which is an interesting topic by itself. For Sobolev-smooth coefficients of exponent greater than 2, they were investigated in [4], [34]. The case of the critical exponent 2 is treated in [12], which apparently provides the first example of well-posedness for the Dirichlet problem in the non-strictly elliptic case: the conductivity may be unbounded or zero on sets of zero capacity and, accordingly, solutions need not be locally bounded. Exponent 2 seems also to be the key to a similar theory on general (rectifiable) domains in the plane, for exponent 2 is all one is left with in general after a conformal transformation of the domain.

Generalized Hardy classes as above are used in [13] where we address the uniqueness issue in the classical Robin inverse problem on a Lipschitz domain of $\Omega \subset \mathbb{R}^n$, $n \geq 2$, with uniformly bounded Robin coefficient, L^2 Neumann data and conductivity of Sobolev class $W^{1,r}(\Omega)$, $r > n$. We show that uniqueness of the Robin coefficient on a subset of the boundary, given Cauchy data on the complementary part, does hold in dimension $n = 2$, thanks to a unique continuation result, but needs not hold in higher dimension. In higher dimension, this raises an open issue on harmonic gradients, namely whether the positivity of the Robin coefficient is compatible with identical vanishing of the boundary gradient on a subset of positive measure.

The 3-D version of step 1 in Section 3.1 is another subject investigated by Apics: to recover a harmonic function (up to an additive constant) in a ball or a half-space from partial knowledge of its gradient. This prototypical inverse problem (*i.e.* inverse to the Cauchy problem for the Laplace equation) often recurs in electromagnetism. At present, Apics is involved with solving instances of this inverse problem arising in two fields, namely medical imaging *e.g.* for electroencephalography (EEG) or magneto-encephalography (MEG), and paleomagnetism (recovery of rocks magnetization) [2], [36], see Section 5.1. In this connection, we collaborate with two groups of partners: Athena Inria project-team, CHU La Timone, and BESA company on the one hand, Geosciences Lab. at MIT and Cerege CNRS Lab. on the other hand. The question is considerably more difficult than its 2-D counterpart, due mainly to the lack of multiplicative structure for harmonic gradients. Still, substantial progress has been made over the last years using methods of harmonic analysis and operator theory.

The team is further concerned with 3-D generalizations and applications to non-destructive control of step 2 in Section 3.1. A typical problem is here to localize inhomogeneities or defaults such as cracks, sources or occlusions in a planar or 3-dimensional object, knowing thermal, electrical, or magnetic measurements on the boundary. These defaults can be expressed as a lack of harmonicity of the solution to the associated Dirichlet-Neumann problem, thereby posing an inverse potential problem in order to recover them. In 2-D, finding an optimal discretization of the potential in Sobolev norm amounts to solve a best rational approximation problem, and the question arises as to how the location of the singularities of the approximant (*i.e.* its poles) reflects the location of the singularities of the potential (*i.e.* the defaults we seek). This is a fairly deep issue in approximation theory, to which Apics contributed convergence results for certain classes of fields expressed as Cauchy integrals over extremal contours for the logarithmic potential [6], [37], [51]. Initial schemes to locate cracks or sources *via* rational approximation on planar domains were obtained this way [40], [44], [54]. It is remarkable that finite inverse source problems in 3-D balls, or more general algebraic surfaces, can be approached using these 2-D techniques upon slicing the domain into planar sections [7], [41]. More precisely, each section cuts out a planar domain, the boundary of which carries data which can be proved to match an algebraic function. The singularities of this algebraic function are not located at the 3-D sources, but are related to them: the section contains a source if and only if some function of the singularities in that section meets a relative extremum. Using bisection it is thus possible to determine an extremal place along all sections parallel to a given plane direction, up to some threshold which has to be chosen small enough that one does not miss a source. This way, we reduce the original source problem in 3-D to a sequence of inverse poles and

branchpoints problems in 2-D. This bottom line generates a steady research activity within Apics, and again applications are sought to medical imaging and geosciences, see Sections 4.3, 4.2 and 5.1.

Conjectures may be raised on the behavior of optimal potential discretization in 3-D, but answering them is an ambitious program still in its infancy.

3.2.2. Systems, transfer and scattering

Participants: Laurent Baratchart, Matthias Caenepeel, Sylvain Chevillard, Martine Olivi, Fabien Seyfert.

Through contacts with CNES (French space agency), members of the team became involved in identification and tuning of microwave electromagnetic filters used in space telecommunications, see Section 4.4. The initial problem was to recover, from band-limited frequency measurements, physical parameters of the device under examination. The latter consists of interconnected dual-mode resonant cavities with negligible loss, hence its scattering matrix is modeled by a 2×2 unitary-valued matrix function on the frequency line, say the imaginary axis to fix ideas. In the bandwidth around the resonant frequency, a modal approximation of the Helmholtz equation in the cavities shows that this matrix is approximately rational, of Mc-Millan degree twice the number of cavities.

This is where system theory comes into play, through the so-called *realization* process mapping a rational transfer function in the frequency domain to a state-space representation of the underlying system of linear differential equations in the time domain. Specifically, realizing the scattering matrix allows one to construct a virtual electrical network, equivalent to the filter, the parameters of which mediate in between the frequency response and the geometric characteristics of the cavities (*i.e.* the tuning parameters).

Hardy spaces provide a framework to transform this ill-posed issue into a series of regularized analytic and meromorphic approximation problems. More precisely, the procedure sketched in Section 3.1 goes as follows:

1. infer from the pointwise boundary data in the bandwidth a stable transfer function (*i.e.* one which is holomorphic in the right half-plane), that may be infinite dimensional (numerically: of high degree). This is done by solving a problem analogous to (P) in Section 3.3.1, while taking into account prior knowledge on the decay of the response outside the bandwidth, see [9] for details.
2. A stable rational approximation of appropriate degree to the model obtained in the previous step is performed. For this, a descent method on the compact manifold of inner matrices of given size and degree is used, based on an original parametrization of stable transfer functions developed within the team [28], [9].
3. Realizations of this rational approximant are computed. To be useful, they must satisfy certain constraints imposed by the geometry of the device. These constraints typically come from the coupling topology of the equivalent electrical network used to model the filter. This network is composed of resonators, coupled according to some specific graph. This realization step can be recast, under appropriate compatibility conditions [55], as solving a zero-dimensional multivariate polynomial system. To tackle this problem in practice, we use Gröbner basis techniques and continuation methods which team up in the Dedale-HF software (see Section 3.4.1).

Let us mention that extensions of classical coupling matrix theory to frequency-dependent (reactive) couplings have been carried-out in recent years [1] for wide-band design applications.

Apics also investigates issues pertaining to design rather than identification. Given the topology of the filter, a basic problem in this connection is to find the optimal response subject to specifications that bear on rejection, transmission and group delay of the scattering parameters. Generalizing the classical approach based on Chebyshev polynomials for single band filters, we recast the problem of multi-band response synthesis as a generalization of the classical Zolotarev min-max problem for rational functions [27] [8]. Thanks to quasi-convexity, the latter can be solved efficiently using iterative methods relying on linear programming. These were implemented in the software easy-FF (see [easy-FF](#)). Currently, the team is engaged in the synthesis of more complex microwave devices like multiplexers and routers, which connect several filters through wave guides. Schur analysis plays an important role here, because scattering matrices of passive systems are of Schur type (*i.e.* contractive in the stability region). The theory originates with the work of I. Schur [75], who

devised a recursive test to check for contractivity of a holomorphic function in the disk. The so-called Schur parameters of a function may be viewed as Taylor coefficients for the hyperbolic metric of the disk, and the fact that Schur functions are contractions for that metric lies at the root of Schur's test. Generalizations thereof turn out to be efficient to parametrize solutions to contractive interpolation problems [29]. Dwelling on this, Apics contributed differential parametrizations (atlases of charts) of lossless matrix functions [28], [71], [65] which are fundamental to our rational approximation software RARL2 (see Section 3.4.4). Schur analysis is also instrumental to approach de-embedding issues, and provides one with considerable insight into the so-called matching problem. The latter consists in maximizing the power a multiport can pass to a given load, and for reasons of efficiency it is all-pervasive in microwave and electric network design, *e.g.* of antennas, multiplexers, wifi cards and more. It can be viewed as a rational approximation problem in the hyperbolic metric, and the team presently deals with this hot topic using contractive interpolation with constraints on boundary peak points, within the framework of the (defense funded) ANR COCORAM, see Sections 5.2 and 7.2.1.

In recent years, our attention was driven by CNES and UPV (Bilbao) to questions about stability of high-frequency amplifiers, see Section 6.2. Contrary to previously discussed devices, these are *active* components. The response of an amplifier can be linearized around a set of primary current and voltages, and then admittances of the corresponding electrical network can be computed at various frequencies, using the so-called harmonic balance method. The initial goal is to check for stability of the linearized model, so as to ascertain existence of a well-defined working state. The network is composed of lumped electrical elements namely inductors, capacitors, negative *and* positive reactors, transmission lines, and controlled current sources. Our research so far has focused on describing the algebraic structure of admittance functions, so as to set up a function-theoretic framework where the two-steps approach outlined in Section 3.1 can be put to work. The main discovery is that the unstable part of each partial transfer function is rational and can be computed by analytic projection, see Section 5.4. We now start investigating the linearized harmonic transfer-function around a periodic cycle, to check for stability under non necessarily small inputs. This generalization generates both doctoral and postdoctoral work by new students in the team.

3.3. Approximation

Participants: Laurent Baratchart, Sylvain Chevillard, Juliette Leblond, Martine Olivi, Dmitry Ponomarev, Fabien Seyfert.

3.3.1. Best analytic approximation

In dimension 2, the prototypical problem to be solved in step 1 of Section 3.1 may be described as: given a domain $D \subset \mathbb{R}^2$, to recover a holomorphic function from its values on a subset K of the boundary of D . For the discussion it is convenient to normalize D , which can be done by conformal mapping. So, in the simply connected case, we fix D to be the unit disk with boundary unit circle T . We denote by H^p the Hardy space of exponent p , which is the closure of polynomials in $L^p(T)$ -norm if $1 \leq p < \infty$ and the space of bounded holomorphic functions in D if $p = \infty$. Functions in H^p have well-defined boundary values in $L^p(T)$, which makes it possible to speak of (traces of) analytic functions on the boundary.

To find an analytic function g in D matching some measured values f approximately on a sub-arc K of T , we formulate a constrained best approximation problem as follows.

(P) Let $1 \leq p \leq \infty$, K a sub-arc of T , $f \in L^p(K)$, $\psi \in L^p(T \setminus K)$ and $M > 0$; find a function $g \in H^p$ such that $\|g - \psi\|_{L^p(T \setminus K)} \leq M$ and $g - f$ is of minimal norm in $L^p(K)$ under this constraint.

Here ψ is a reference behavior capturing *a priori* assumptions on the behavior of the model off K , while M is some admissible deviation thereof. The value of p reflects the type of stability which is sought and how much one wants to smooth out the data. The choice of L^p classes is suited to handle pointwise measurements.

To fix terminology, we refer to (P) as a *bounded extremal problem*. As shown in [39], [42], [48], the solution to this convex infinite-dimensional optimization problem can be obtained when $p \neq 1$ upon iterating with respect to a Lagrange parameter the solution to spectral equations for appropriate Hankel and Toeplitz operators. These spectral equations involve the solution to the special case $K = T$ of (P) , which is a standard extremal problem [63]:

(P_0) Let $1 \leq p \leq \infty$ and $\varphi \in L^p(T)$; find a function $g \in H^p$ such that $g - \varphi$ is of minimal norm in $L^p(T)$.

The case $p = 1$ is more or less open.

Various modifications of (P) can be tailored to meet specific needs. For instance when dealing with lossless transfer functions (see Section 4.4), one may want to express the constraint on $T \setminus K$ in a pointwise manner: $|g - \psi| \leq M$ a.e. on $T \setminus K$, see [43]. In this form, the problem comes close to (but still is different from) H^∞ frequency optimization used in control [66], [74]. One can also impose bounds on the real or imaginary part of $g - \psi$ on $T \setminus K$, which is useful when considering Dirichlet-Neumann problems, see [68].

The analog of Problem (P) on an annulus, K being now the outer boundary, can be seen as a means to regularize a classical inverse problem occurring in nondestructive control, namely to recover a harmonic function on the inner boundary from Dirichlet-Neumann data on the outer boundary (see Sections 3.2.1, 4.3, 5.1.5). It may serve as a tool to approach Bernoulli type problems, where we are given data on the outer boundary and we *seek the inner boundary*, knowing it is a level curve of the solution. In this case, the Lagrange parameter indicates how to deform the inner contour in order to improve data fitting. Similar topics are discussed in Section 3.2.1 for more general equations than the Laplacian, namely isotropic conductivity equations of the form $\operatorname{div}(\sigma \nabla u) = 0$ where σ is no longer constant. Then, the Hardy spaces in Problem (P) are those of a so-called conjugate Beltrami equation: $\bar{\partial} f = \nu \bar{\partial} \bar{f}$ [67], which are studied for $1 < p < \infty$ in [4], [12], [34] and [58]. Expansions of solutions needed to constructively handle such issues in the specific case of linear fractional conductivities (occurring for instance in plasma shaping) have been expounded in [60].

Another instance of problem (P) in with $p = 2$ and additional pointwise interpolation constraints inside a simply connected domain (disk) D was studied and solved in [11], Part I, and [15]. Such pointwise interpolation constraints could be of practical interest for inverse Cauchy type problems in cases where interior information is also available or to model uncertainty on boundary data.

Though originally considered in dimension 2, Problem (P) carries over naturally to higher dimensions where analytic functions get replaced by gradients of harmonic functions. Namely, given some open set $\Omega \subset \mathbb{R}^n$ and some \mathbb{R}^n -valued vector field V on an open subset O of the boundary of Ω , we seek a harmonic function in Ω whose gradient is close to V on O .

When Ω is a ball or a half-space, a substitute for holomorphic Hardy spaces is provided by the Stein-Weiss Hardy spaces of harmonic gradients [77]. Conformal maps are no longer available when $n > 2$, so that Ω can no longer be normalized. More general geometries than spheres and half-spaces have not been much studied so far.

On the ball, the analog of Problem (P) is

(P_1) Let $1 \leq p \leq \infty$ and $B \subset \mathbb{R}^n$ the unit ball. Fix O an open subset of the unit sphere $S \subset \mathbb{R}^n$. Let further $V \in L^p(O)$ and $W \in L^p(S \setminus O)$ be \mathbb{R}^n -valued vector fields. Given $M > 0$, find a harmonic gradient $G \in H^p(B)$ such that $\|G - W\|_{L^p(S \setminus O)} \leq M$ and $G - V$ is of minimal norm in $L^p(O)$ under this constraint.

When $p = 2$, Problem (P_1) was solved in [2] as well as its analog on a shell, when the tangent component of V is a gradient (when O is Lipschitz the general case follows easily from this). The solution extends the work in [39] to the 3-D case, using a generalization of Toeplitz operators. The case of the shell was motivated by applications to the processing of EEG data. An important ingredient is a refinement of the Hodge decomposition, that we call the *Hardy-Hodge* decomposition, allowing us to express a \mathbb{R}^n -valued vector field in $L^p(S)$, $1 < p < \infty$, as the sum of a vector field in $H^p(B)$, a vector field in $H^p(\mathbb{R}^n \setminus \bar{B})$, and a tangential divergence free vector field on S ; the space of such divergence-free fields is denoted by $D(S)$. If $p = 1$ or

$p = \infty$, L^p must be replaced by the real Hardy space or the space of functions with bounded mean oscillation. More generally this decomposition, which is valid on any sufficiently smooth surface (see Section 5.1), seems to play a fundamental role in inverse potential problems. In fact, it was first introduced formally on the plane to describe silent magnetizations supported in \mathbb{R}^2 (*i.e.* those generating no field in the upper half space) [36].

Just like solving problem (P) appeals to the solution of problem (P_0) , our ability to solve problem (P_1) will depend on the possibility to tackle the special case where $O = S$:

(P_2) Let $1 \leq p \leq \infty$ and $V \in L^p(S)$ be a \mathbb{R}^n -valued vector field. Find a harmonic gradient $G \in H^p(B)$ such that $\|G - V\|_{L^p(S)}$ is minimum.

Problem (P_2) is simple when $p = 2$ by virtue of the Hardy Hodge decomposition together with orthogonality of $H^2(B)$ and $H^2(\mathbb{R}^n \setminus \overline{B})$, which is the reason why we were able to solve (P_1) in this case. Other values of p cannot be treated as easily and are still under investigation, especially the case $p = \infty$ which is of particular interest and presents itself as a 3-D analog to the Nehari problem [73].

Companion to problem (P_2) is problem (P_3) below.

(P_3) Let $1 \leq p \leq \infty$ and $V \in L^p(S)$ be a \mathbb{R}^n -valued vector field. Find $G \in H^p(B)$ and $D \in D(S)$ such that $\|G + D - V\|_{L^p(S)}$ is minimum.

Note that (P_2) and (P_3) are identical in 2-D, since no non-constant tangential divergence-free vector field exists on T . It is no longer so in higher dimension, where both (P_2) and (P_3) arise in connection with inverse potential problems in divergence form, like source recovery in electro/magneto encephalography and paleomagnetism, see Sections 3.2.1 and 4.3.

3.3.2. Best meromorphic and rational approximation

The techniques set forth in this section are used to solve step 2 in Section 3.2 and they are instrumental to approach inverse boundary value problems for the Poisson equation $\Delta u = \mu$, where μ is some (unknown) measure.

3.3.2.1. Scalar meromorphic and rational approximation

We put R_N for the set of rational functions with at most N poles in D . By definition, meromorphic functions in $L^p(T)$ are (traces of) functions in $H^p + R_N$.

A natural generalization of problem (P_0) is:

(P_N) Let $1 \leq p \leq \infty$, $N \geq 0$ an integer, and $f \in L^p(T)$; find a function $g_N \in H^p + R_N$ such that $g_N - f$ is of minimal norm in $L^p(T)$.

Only for $p = \infty$ and f continuous is it known how to solve (P_N) in semi-closed form. The unique solution is given by AAK theory (named after Adamjan, Arov and Krein), which connects the spectral decomposition of Hankel operators with best approximation [73].

The case where $p = 2$ is of special importance for it reduces to rational approximation. Indeed, if we write the Hardy decomposition $f = f^+ + f^-$ where $f^+ \in H^2$ and $f^- \in H^2(\mathbb{C} \setminus \overline{D})$, then $g_N = f^+ + r_N$ where r_N is a best approximant to f^- from R_N in $L^2(T)$. Moreover, r_N has no pole outside D , hence it is a *stable* rational approximant to f^- . However, in contrast to the case where $p = \infty$, this best approximant may *not* be unique.

The former Miaou project (predecessor of Apics) designed a dedicated steepest-descent algorithm for the case $p = 2$ whose convergence to a *local minimum* is guaranteed; until now it seems to be the only procedure meeting this property. This gradient algorithm proceeds recursively with respect to N on a compactification of the parameter space [32]. Although it has proved to be effective in all applications carried out so far (see Sections 4.3, 4.4), it is still unknown whether the absolute minimum can always be obtained by choosing initial conditions corresponding to *critical points* of lower degree (as is done by the RARL2 software, Section 3.4.4).

In order to establish global convergence results, Apics has undertaken a deeper study of the number and nature of critical points (local minima, saddle points...), in which tools from differential topology and operator theory team up with classical interpolation theory [45], [47]. Based on this work, uniqueness or asymptotic uniqueness of the approximant was proved for certain classes of functions like transfer functions of relaxation systems (*i.e.* Markov functions) [49] and more generally Cauchy integrals over hyperbolic geodesic arcs [52]. These are the only results of this kind. Research by Apics on this topic remained dormant for a while by reasons of opportunity, but revisiting the work [30] in higher dimension is a worthy and timely endeavor today. Meanwhile, an analog to AAK theory was carried out for $2 \leq p < \infty$ in [48]. Although not as effective computationally, it was recently used to derive lower bounds [3]. When $1 \leq p < 2$, problem (P_N) is still quite open.

A common feature to the above-mentioned problems is that critical point equations yield non-Hermitian orthogonality relations for the denominator of the approximant. This stresses connections with interpolation, which is a standard way to build approximants, and in many respects best or near-best rational approximation may be regarded as a clever manner to pick interpolation points. This was exploited in [53], [50], and is used in an essential manner to assess the behavior of poles of best approximants to functions with branched singularities, which is of particular interest for inverse source problems (*cf.* Sections 3.4.2 and 5.1).

In higher dimensions, the analog of Problem (P_N) is best approximation of a vector field by gradients of discrete potentials generated by N point masses. This basic issue is by no means fully understood, and it is an exciting field of research. It is connected with certain generalizations of Toeplitz or Hankel operators, and with constructive approaches to so-called weak factorizations for real Hardy functions [59].

Besides, certain constrained rational approximation problems, of special interest in identification and design of passive systems, arise when putting additional requirements on the approximant, for instance that it should be smaller than 1 in modulus (*i.e.* a Schur function). In particular, Schur interpolation lately received renewed attention from the team, in connection with matching problems. There, interpolation data are subject to a well-known compatibility condition (positive definiteness of the so-called Pick matrix), and the main difficulty is to put interpolation points on the boundary of D while controlling both the degree and the extremal points (peak points for the modulus) of the interpolant. Results obtained by Apics in this direction generalize a variant of contractive interpolation with degree constraint as studied in [64], see Section 5.2. We mention that contractive interpolation with nodes approaching the boundary has been a subsidiary research topic by the team in the past, which plays an interesting role in the spectral representation of certain non-stationary stochastic processes [35], [38]. The subject is intimately connected to orthogonal polynomials on the unit circle, and this line of investigation has been pursued towards an asymptotic study of orthogonal polynomials on planar domains, which is today an active area in approximation theory with application to quantum particle systems, spectra of random matrices, and Hele-Shaw flows, see Section 5.6.

3.3.2.2. Matrix-valued rational approximation

Matrix-valued approximation is necessary to handle systems with several inputs and outputs but it generates additional difficulties as compared to scalar-valued approximation, both theoretically and algorithmically. In the matrix case, the McMillan degree (*i.e.* the degree of a minimal realization in the System-Theoretic sense) generalizes the usual notion of degree for rational functions. For instance when poles are simple, the McMillan degree is the sum of the ranks of the residues.

The basic problem that we consider now goes as follows: let $\mathcal{F} \in (H^2)^{m \times l}$ and n an integer; find a rational matrix of size $m \times l$ without poles in the unit disk and of McMillan degree at most n which is nearest possible to \mathcal{F} in $(H^2)^{m \times l}$. Here the L^2 norm of a matrix is the square root of the sum of the squares of the norms of its entries.

The scalar approximation algorithm derived in [32] and mentioned in Section 3.3.2.1 generalizes to the matrix-valued situation [62]. The first difficulty here is to parametrize inner matrices (*i.e.* matrix-valued functions analytic in the unit disk and unitary on the unit circle) of given McMillan degree degree n . Indeed, inner matrices play the role of denominators in fractional representations of transfer matrices (using the so-called Douglas-Shapiro-Shields factorization). The set of inner matrices of given degree is a smooth manifold that

allows one to use differential tools as in the scalar case. In practice, one has to produce an atlas of charts (local parametrizations) and to handle changes of charts in the course of the algorithm. Such parametrization can be obtained using interpolation theory and Schur-type algorithms, the parameters of which are vectors or matrices ([28], [65], [71]). Some of these parametrizations are also interesting to compute realizations and achieve filter synthesis ([65], [71]). The rational approximation software “RARL2” developed by the team is described in Section 3.4.4.

Difficulties relative to multiple local minima of course arise in the matrix-valued case as well, and deriving criteria that guarantee uniqueness is even more difficult than in the scalar case. The case of rational functions of degree n or small perturbations thereof (the consistency problem) was solved in [46]. Matrix-valued Markov functions are the only known example beyond this one [31].

Let us stress that RARL2 seems the only algorithm handling rational approximation in the matrix case that demonstrably converges to a local minimum while meeting stability constraints on the approximant. It is still a working pin of many developments by Apics on frequency optimization and design.

3.3.3. Behavior of poles of meromorphic approximants

Participant: Laurent Baratchart.

We refer here to the behavior of poles of best meromorphic approximants, in the L^p -sense on a closed curve, to functions f defined as Cauchy integrals of complex measures whose support lies inside the curve. Normalizing the contour to be the unit circle T , we are back to Problem (P_N) in Section 3.3.2.1; invariance of the latter under conformal mapping was established in [5]. Research so far has focused on functions whose singular set inside the contour is polar, meaning that the function can be continued analytically (possibly in a multiple-valued manner) except over a set of logarithmic capacity zero.

Generally speaking in approximation theory, assessing the behavior of poles of rational approximants is essential to obtain error rates as the degree goes large, and to tackle constructive issues like uniqueness. However, as explained in Section 3.2.1, the original twist by Apics is to consider this issue also as a means to extract information on singularities of the solution to a Dirichlet-Neumann problem. The general theme is thus: *how do the singularities of the approximant reflect those of the approximated function?* This approach to inverse problem for the 2-D Laplacian turns out to be attractive when singularities are zero- or one-dimensional (see Section 4.3). It can be used as a computationally cheap initial condition for more precise but much heavier numerical optimizations which often do not even converge unless properly initialized. As regards crack detection or source recovery, this approach boils down to analyzing the behavior of best meromorphic approximants of given pole cardinality to a function with branch points, which is the prototype of a polar singular set. For piecewise analytic cracks, or in the case of sources, we were able to prove ([5], [6], [37]), that the poles of the approximants accumulate, when the degree goes large, to some extremal cut of minimum weighted logarithmic capacity connecting the singular points of the crack, or the sources [40]. Moreover, the asymptotic density of the poles turns out to be the Green equilibrium distribution on this cut in D , therefore it charges the singular points if one is able to approximate in sufficiently high degree (this is where the method could fail, because high-order approximation requires rather precise data).

The case of two-dimensional singularities is still an outstanding open problem.

It is remarkable that inverse source problems inside a sphere or an ellipsoid in 3-D can be approached with such 2-D techniques, as applied to planar sections, see Section 5.1. The technique is implemented in the software FindSources3D, see Section 3.4.2.

3.4. Software tools of the team

In addition to the above-mentioned research activities, Apics develops and maintains a number of long-term software tools that either implement and illustrate effectiveness of the algorithms theoretically developed by the team or serve as tools to help further research by team members. We present briefly the most important of them.

3.4.1. DEDALE-HF

SCIENTIFIC DESCRIPTION

Dedale-HF consists in two parts: a database of coupling topologies as well as a dedicated predictor-corrector code. Roughly speaking each reference file of the database contains, for a given coupling topology, the complete solution to the coupling matrix synthesis problem (C.M. problem for short) associated to particular filtering characteristics. The latter is then used as a starting point for a predictor-corrector integration method that computes the solution to the C.M. corresponding to the user-specified filter characteristics. The reference files are computed off-line using Gröbner basis techniques or numerical techniques based on the exploration of a monodromy group. The use of such continuation techniques, combined with an efficient implementation of the integrator, drastically reduces the computational time.

Dedale-HF has been licensed to, and is currently used by TAS-Espana

FUNCTIONAL DESCRIPTION

Dedale-HF is a software dedicated to solve exhaustively the coupling matrix synthesis problem in reasonable time for the filtering community. Given a coupling topology, the coupling matrix synthesis problem consists in finding all possible electromagnetic coupling values between resonators that yield a realization of given filter characteristics. Solving the latter is crucial during the design step of a filter in order to derive its physical dimensions, as well as during the tuning process where coupling values need to be extracted from frequency measurements.

- Participant: Fabien Seyfert
- Contact: Fabien Seyfert
- URL: <http://www-sop.inria.fr/apics/Dedale/>

3.4.2. FindSources3D

FindSources3D-bolis

KEYWORDS: Health - Neuroimaging - Visualization - Compilers - Medical - Image - Processing

FUNCTIONAL DESCRIPTION

FindSources3D is a software program dedicated to the resolution of inverse source problems in electroencephalography (EEG). From pointwise measurements of the electrical potential taken by electrodes on the scalp, FindSources3D estimates pointwise dipolar current sources within the brain in a spherical model.

After a first data transmission “cortical mapping” step, it makes use of best rational approximation on 2-D planar cross-sections and of the software RARL2 in order to locate singularities. From those planar singularities, the 3-D sources are estimated in a last step.

This version of FindSources3D provides a modular, ergonomic, accessible and interactive platform, with a convenient graphical interface and a tool that can be distributed and used, for EEG medical imaging. Modularity is now granted (using the tools dtk, Qt, with compiled Matlab libraries). It offers a detailed and nice visualization of data and tuning parameters, processing steps, and of the computed results (using VTK).

- Participants: Juliette Leblond, Maureen Clerc Gallagher, Théodore Papadopoulo, Jean-Paul Marmorat and Nicolas Schnitzler
- Contact: Juliette Leblond
- URL: <http://www-sop.inria.fr/apics/FindSources3D/en/index.html>

3.4.3. PRESTO-HF

SCIENTIFIC DESCRIPTION

For the matrix-valued rational approximation step, Presto-HF relies on RARL2. Constrained realizations are computed using the Dedale-HF software. As a toolbox, Presto-HF has a modular structure, which allows one for example to include some building blocks in an already existing software.

The delay compensation algorithm is based on the following assumption: far off the pass-band, one can reasonably expect a good approximation of the rational components of S_{11} and S_{22} by the first few terms of their Taylor expansion at infinity, a small degree polynomial in $1/s$. Using this idea, a sequence of quadratic convex optimization problems are solved, in order to obtain appropriate compensations. In order to check the previous assumption, one has to measure the filter on a larger band, typically three times the pass band.

This toolbox has been licensed to, and is currently used by Thales Alenia Space in Toulouse and Madrid, Thales airborne systems and Flextronics (two licenses). XLIM (University of Limoges) is a heavy user of Presto-HF among the academic filtering community and some free license agreements have been granted to the microwave department of the University of Erlangen (Germany) and the Royal Military College (Kingston, Canada).

FUNCTIONAL DESCRIPTION

Presto-HF is a toolbox dedicated to low-pass parameter identification for microwave filters. In order to allow the industrial transfer of our methods, a Matlab-based toolbox has been developed, dedicated to the problem of identification of low-pass microwave filter parameters. It allows one to run the following algorithmic steps, either individually or in a single stroke:

- Determination of delay components caused by the access devices (automatic reference plane adjustment),
- Automatic determination of an analytic completion, bounded in modulus for each channel,
- Rational approximation of fixed McMillan degree,
- Determination of a constrained realization.
 - Participants: Fabien Seyfert, Jean-Paul Marmorat and Martine Olivi
 - Contact: Fabien Seyfert
 - URL: <https://project.inria.fr/presto-hf/>

3.4.4. RARL2

Réalisation interne et Approximation Rationnelle L2

SCIENTIFIC DESCRIPTION

The method is a steepest-descent algorithm. A parametrization of MIMO systems is used, which ensures that the stability constraint on the approximant is met. The implementation, in Matlab, is based on state-space representations.

RARL2 performs the rational approximation step in the software tools PRESTO-HF and FindSources3D. It is distributed under a particular license, allowing unlimited usage for academic research purposes. It was released to the universities of Delft and Maastricht (the Netherlands), Cork (Ireland), Brussels (Belgium), Macao (China) and BITS-Pilani Hyderabad Campus (India).

FUNCTIONAL DESCRIPTION

RARL2 is a software for rational approximation. It computes a stable rational L2-approximation of specified order to a given L2-stable (L2 on the unit circle, analytic in the complement of the unit disk) matrix-valued function. This can be the transfer function of a multivariable discrete-time stable system. RARL2 takes as input either:

- its internal realization,
- its first N Fourier coefficients,
- discretized (uniformly distributed) values on the circle. In this case, a least-square criterion is used instead of the L2 norm.

It thus performs model reduction in the first or the second case, and leans on frequency data identification in the third. For band-limited frequency data, it could be necessary to infer the behavior of the system outside the bandwidth before performing rational approximation.

An appropriate Möbius transformation allows to use the software for continuous-time systems as well.

- Participants: Jean-Paul Marmorat and Martine Olivi
- Contact: Martine Olivi
- URL: <http://www-sop.inria.fr/apics/RARL2/rarl2.html>

3.4.5. *Sollya*

KEYWORDS: Numerical algorithm - Supremum norm - Curve plotting - Remez algorithm - Code generator - Proof synthesis

FUNCTIONAL DESCRIPTION

Sollya is an interactive tool where the developers of mathematical floating-point libraries (libm) can experiment before actually developing code. The environment is safe with respect to floating-point errors, i.e. the user precisely knows when rounding errors or approximation errors happen, and rigorous bounds are always provided for these errors.

Among other features, it offers a fast Remez algorithm for computing polynomial approximations of real functions and also an algorithm for finding good polynomial approximants with floating-point coefficients to any real function. As well, it provides algorithms for the certification of numerical codes, such as Taylor Models, interval arithmetic or certified supremum norms.

It is available as a free software under the CeCILL-C license.

- Participants: Sylvain Chevillard, Christoph Lauter, Mioara Joldes and Nicolas Jourdan
- Partners: CNRS - ENS Lyon - UCBL Lyon 1
- Contact: Sylvain Chevillard
- URL: <http://sollya.gforge.inria.fr/>

4. Application Domains

4.1. Introduction

Application domains are naturally linked to the problems described in Sections 3.2.1 and 3.2.2. By and large, they split into a systems-and-circuits part and an inverse-source-and-boundary-problems part, united under a common umbrella of function-theoretic techniques as described in Section 3.3.

4.2. Inverse magnetization problems

Participants: Laurent Baratchart, Sylvain Chevillard, Juliette Leblond, Konstantinos Mavreas, Dmitry Ponomarev.

Generally speaking, inverse potential problems, similar to the one appearing in Section 4.3, occur naturally in connection with systems governed by Maxwell's equation in the quasi-static approximation regime. In particular, they arise in magnetic reconstruction issues. A specific application is to geophysics, which led us to form the Inria Associate Team "IMPINGE" (Inverse Magnetization Problems IN GEosciences) together with MIT and Vanderbilt University. A recent collaboration with Cerege (CNRS, Aix-en-Provence), in the framework of the ANR-project MagLune, completes this picture, see Section 7.2.2.

To set up the context, recall that the Earth's geomagnetic field is generated by convection of the liquid metallic core (geodynamo) and that rocks become magnetized by the ambient field as they are formed or after subsequent alteration. Their remanent magnetization provides records of past variations of the geodynamo, which is used to study important processes in Earth sciences like motion of tectonic plates and geomagnetic reversals. Rocks from Mars, the Moon, and asteroids also contain remanent magnetization which indicates the past presence of core dynamos. Magnetization in meteorites may even record fields produced by the young sun and the protoplanetary disk which may have played a key role in solar system formation.

For a long time, paleomagnetic techniques were only capable of analyzing bulk samples and compute their net magnetic moment. The development of SQUID microscopes has recently extended the spatial resolution to sub-millimeter scales, raising new physical and algorithmic challenges. The associate team IMPINGE aims at tackling them, experimenting with the SQUID microscope set up in the Paleomagnetism Laboratory of the department of Earth, Atmospheric and Planetary Sciences at MIT. Typically, pieces of rock are sanded down to a thin slab, and the magnetization has to be recovered from the field measured on a planar region at small distance from the slab.

Mathematically speaking, both inverse source problems for EEG from Section 4.3 and inverse magnetization problems described presently amount to recover the (3-D valued) quantity m (primary current density in case of the brain or magnetization in case of a thin slab of rock) from measurements of the potential:

$$\int_{\Omega} \frac{\operatorname{div} m(x') dx'}{|x-x'|}, \quad (1)$$

outside the volume Ω of the object. The difference is that the distribution m is located in a volume in the case of EEG, and on a plane in the case of rock magnetization. This results in quite different identifiability properties, see [36] and Section 5.1.1, but the two situations share a substantial Mathematical common core.

Another timely instance of inverse magnetization problems lies with geomagnetism. Satellites orbiting around the Earth measure the magnetic field at many points, and nowadays it is a challenge to extract global information from those measurements. In collaboration with C. Gerhards from the University of Vienna, Apics has started to work on the problem of separating the magnetic field due to the magnetization of the globe's crust from the magnetic field due to convection in the liquid metallic core. The techniques involves are variants, in a spherical context, from those developed within the IMPINGE associate team for paleomagnetism, see Section 5.1.4.

4.3. Inverse source problems in EEG

Participants: Laurent Baratchart, Juliette Leblond, Jean-Paul Marmorat, Christos Papageorgakis, Nicolas Schnitzler.

This work is conducted in collaboration with Maureen Clerc and Théo Papadopoulo from the Athena EPI.

Solving overdetermined Cauchy problems for the Laplace equation on a spherical layer (in 3-D) in order to extrapolate incomplete data (see Section 3.2.1) is a necessary ingredient of the team's approach to inverse source problems, in particular for applications to EEG, see [7]. Indeed, the latter involves propagating the initial conditions through several layers of different conductivities, from the boundary shell down to the center of the domain where the singularities (*i.e.* the sources) lie. Once propagated to the innermost sphere, it turns out that traces of the boundary data on 2-D cross sections coincide with analytic functions with branched singularities in the slicing plane [6], [41]. The singularities are related to the actual location of the sources, namely their moduli reach in turn a maximum when the plane contains one of the sources. Hence we are back to the 2-D framework of Section 3.3.3, and recovering these singularities can be performed *via* best rational approximation. The goal is to produce a fast and sufficiently accurate initial guess on the number and location of the sources in order to run heavier descent algorithms on the direct problem, which are more precise but computationally costly and often fail to converge if not properly initialized. Our belief is that such a localization process can add a geometric, valuable piece of information to the standard temporal analysis of EEG signal records.

Numerical experiments obtained with our software FindSources3D give very good results on simulated data and we are now engaged in the process of handling real experimental data (see Sections 3.4.2 and 5.1), in collaboration with the Athena team at Inria Sophia Antipolis, neuroscience teams in partner-hospitals (la Timone, Marseille), and the BESA company (Munich).

4.4. Identification and design of microwave devices

Participants: Laurent Baratchart, Sylvain Chevillard, Jean-Paul Marmorat, Martine Olivi, Fabien Seyfert.

This is joint work with Stéphane Bila (XLIM, Limoges).

One of the best training grounds for function-theoretic applications by the team is the identification and design of physical systems whose performance is assessed frequency-wise. This is the case of electromagnetic resonant systems which are of common use in telecommunications.

In space telecommunications (satellite transmissions), constraints specific to on-board technology lead to the use of filters with resonant cavities in the microwave range. These filters serve multiplexing purposes (before or after amplification), and consist of a sequence of cylindrical hollow bodies, magnetically coupled by irises (orthogonal double slits). The electromagnetic wave that traverses the cavities satisfies the Maxwell equations, forcing the tangent electrical field along the body of the cavity to be zero. A deeper study of the Helmholtz equation states that an essentially discrete set of wave vectors is selected. In the considered range of frequency, the electrical field in each cavity can be decomposed along two orthogonal modes, perpendicular to the axis of the cavity (other modes are far off in the frequency domain, and their influence can be neglected).



Figure 1. Picture of a 6-cavities dual mode filter. Each cavity (except the last one) has 3 screws to couple the modes within the cavity, so that 16 quantities must be optimized. Quantities such as the diameter and length of the cavities, or the width of the 11 slits are fixed during the design phase.

Each cavity (see Figure 1) has three screws, horizontal, vertical and midway (horizontal and vertical are two arbitrary directions, the third direction makes an angle of 45 or 135 degrees, the easy case is when all cavities show the same orientation, and when the directions of the irises are the same, as well as the input and output slits). Since screws are conductors, they behave as capacitors; besides, the electrical field on the surface has to be zero, which modifies the boundary conditions of one of the two modes (for the other mode, the electrical field is zero hence it is not influenced by the screw), the third screw acts as a coupling between the two modes. The effect of an iris is opposite to that of a screw: no condition is imposed on a hole, which results in a coupling between two horizontal (or two vertical) modes of adjacent cavities (in fact the iris is the union of two rectangles, the important parameter being their width). The design of a filter consists in finding the size of each cavity, and the width of each iris. Subsequently, the filter can be constructed and tuned by adjusting the screws. Finally, the screws are glued once a satisfactory response has been obtained. In what follows, we shall consider a typical example, a filter designed by the CNES in Toulouse, with four cavities near 11 GHz.

Near the resonance frequency, a good approximation to the Helmholtz equations is given by a second order differential equation. Thus, one obtains an electrical model of the filter as a sequence of electrically-coupled resonant circuits, each circuit being modeled by two resonators, one per mode, the resonance frequency of which represents the frequency of a mode, and whose resistance accounts for electric losses (surface currents) in the cavities.

This way, the filter can be seen as a quadripole, with two ports, when plugged onto a resistor at one end and fed with some potential at the other end. One is now interested in the power which is transmitted and reflected. This leads one to define a scattering matrix S , which may be considered as the transfer function of a stable causal linear dynamical system, with two inputs and two outputs. Its diagonal terms $S_{1,1}$, $S_{2,2}$ correspond to reflections at each port, while $S_{1,2}$, $S_{2,1}$ correspond to transmission. These functions can be measured at certain frequencies (on the imaginary axis). The matrix S is approximately rational of order 4 times the number of cavities (that is 16 in the example on Figure 2), and the key step consists in expressing the components of the equivalent electrical circuit as functions of the S_{ij} (since there are no formulas expressing the lengths of the screws in terms of parameters of this electrical model). This representation is also useful to analyze the numerical simulations of the Maxwell equations, and to check the quality of a design, in particular the absence of higher resonant modes.

In fact, resonance is not studied via the electrical model, but via a low-pass equivalent circuit obtained upon linearizing near the central frequency, which is no longer conjugate symmetric (*i.e.* the underlying system may no longer have real coefficients) but whose degree is divided by 2 (8 in the example).

In short, the strategy for identification is as follows:

- measuring the scattering matrix of the filter near the optimal frequency over twice the pass band (which is 80MHz in the example).
- Solving bounded extremal problems for the transmission and the reflection (the modulus of the response being respectively close to 0 and 1 outside the interval measurement, cf. Section 3.3.1) in order to get a model for the scattering matrix as an analytic matrix-valued function. This provides us with a scattering matrix known to be close to a rational matrix of order roughly 1/4 of the number of data points.
- Approximating this scattering matrix by a true rational transfer-function of appropriate degree (8 in this example) via the Endymion or RARL2 software (cf. Section 3.3.2.2).
- A state space realization of S , viewed as a transfer function, can then be obtained, where additional symmetry constraints coming from the reciprocity law and possibly other physical features of the device have to be imposed.
- Finally one builds a realization of the approximant and looks for a change of variables that eliminates non-physical couplings. This is obtained by using algebraic-solvers and continuation algorithms on the group of orthogonal complex matrices (symmetry forces this type of transformation).

The final approximation is of high quality. This can be interpreted as a confirmation of the linearity assumption on the system: the relative L^2 error is less than 10^{-3} . This is illustrated by a reflection diagram (Figure 2). Non-physical couplings are less than 10^{-2} .

The above considerations are valid for a large class of filters. These developments have also been used for the design of non-symmetric filters, which are useful for the synthesis of repeating devices.

The team further investigates problems relative to the design of optimal responses for microwave devices. The resolution of a quasi-convex Zolotarev problems was proposed, in order to derive guaranteed optimal multi-band filter responses subject to modulus constraints [8]. This generalizes the classical single band design techniques based on Chebyshev polynomials and elliptic functions. The approach relies on the fact that the modulus of the scattering parameter $|S_{1,2}|$ admits a simple expression in terms of the filtering function $D = |S_{1,1}|/|S_{1,2}|$, namely

$$|S_{1,2}|^2 = \frac{1}{1 + D^2}.$$

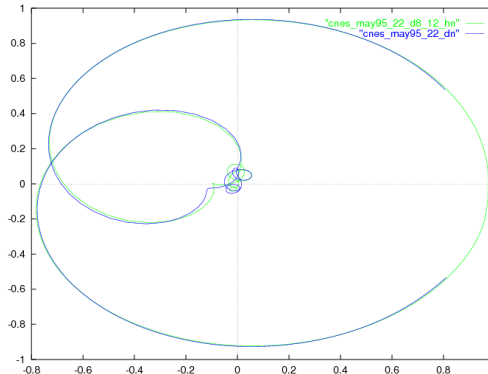

Figure 2. Nyquist Diagram. Rational approximation (degree 8) and data - S_{22} .

The filtering function appears to be the ratio of two polynomials p_1/p_2 , the numerator of the reflection and transmission scattering factors, that may be chosen freely. The denominator q is then obtained as the unique stable unitary polynomial solving the classical Feldtkeller spectral equation:

$$qq^* = p_1p_1^* + p_2p_2^*.$$

The relative simplicity of the derivation of a filter's response, under modulus constraints, owes much to the possibility of forgetting about Feldtkeller's equation and express all design constraints in terms of the filtering function. This no longer the case when considering the synthesis N -port devices for $N > 3$, like multiplexers, routers and power dividers, or when considering the synthesis of filters under matching conditions. The efficient derivation of multiplexers responses is the subject of recent investigation by Apics, using techniques based on constrained Nevanlinna-Pick interpolation (see Section 5.2).

Through contacts with CNES (Toulouse) and UPV (Bilbao), Apics got additionally involved in the design of amplifiers which, unlike filters, are active devices. A prominent issue here is stability. A twenty years back, it was not possible to simulate unstable responses, and only after building a device could one detect instability. The advent of so-called *harmonic balance* techniques, which compute steady state responses of linear elements in the frequency domain and look for a periodic state in the time domain of a network connecting these linear elements *via* static non-linearities made it possible to compute the harmonic response of a (possibly nonlinear and unstable) device [78]. This has had tremendous impact on design, and there is a growing demand for software analyzers. The team is also becoming active in this area.

In this connection, there are two types of stability involved. The first is stability of a fixed point around which the linearized transfer function accounts for small signal amplification. The second is stability of a limit cycle which is reached when the input signal is no longer small and truly nonlinear amplification is attained (*e.g.* because of saturation). Work by the team so far has been concerned with the first type of stability, and emphasis is put on defining and extracting the "unstable part" of the response, see Section 5.4. The stability check for limit cycles is now under investigation.

5. New Results

5.1. Inverse problems for Poisson-Laplace equations

Participants: Laurent Baratchart, Sylvain Chevillard, Juliette Leblond, Konstantinos Mavreas, Christos Papageorgakis, Dmitry Ponomarev.

This section is concerned with inverse problems for 3-D Poisson-Laplace equations, among which source recovery issues. Though the geometrical settings differ in Sections 5.1.1 and 5.1.5, the characterization of silent sources (those giving rise to a vanishing field) is one common problem to both cases. The latter has been resolved in the magnetization setup for thin slabs [36]. The case of volumetric distribution is currently being investigated, starting with magnetization distributions on closed surfaces to which the general volumetric case can be reduced by balayage.

5.1.1. Inverse magnetization issues in the thin-plate framework

This work is carried out in the framework of the Inria Associate Team IMPINGE, comprising Eduardo Andrade Lima and Benjamin Weiss from the Earth Sciences department at MIT (Boston, USA) and Douglas Hardin, Michael Northington, Edward Saff and Cristobal Villalobos from the Mathematics department at Vanderbilt University (Nashville, USA).

The overall goal of IMPINGE is to determine magnetic properties of rock samples (*e.g.* meteorites or stalactites) from weak field measurements close to the sample that can nowadays be obtained using SQUIDs (superconducting quantum interference devices). During previous years, we always considered the case when the rock is cut into slabs so thin that the magnetization distribution could be considered to lie in a plane. This year, we started considering the situation where the thickness r of the sample cannot be ignored. The thin-slab case thus appears as a limiting case when r goes to 0.

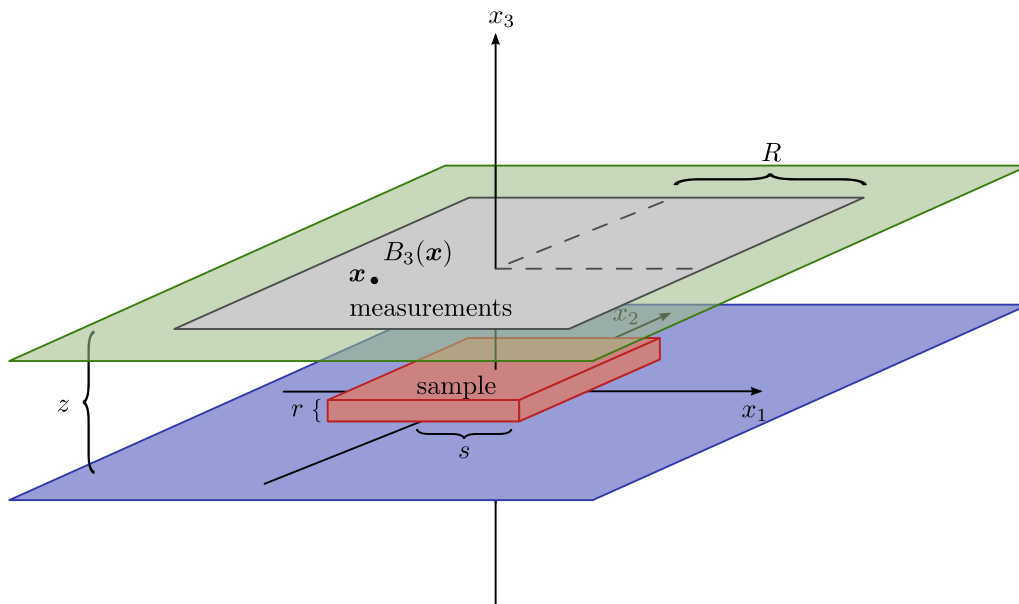

Figure 3. Schematic view of the experimental setup

Figure 3 presents a schematic view of the experimental setup: the sample lies on a horizontal plane at height 0 and its support is included in a parallelepiped. The vertical component B_3 of the field produced by the sample is measured on points of a horizontal square at height z .

We focused on net moment recovery, the net moment of a magnetization being given by its mean value on the sample. The net moment is a valuable piece of information to Physicists and has the advantage of being well-defined: whereas two different magnetizations can generate the same field, the net moment depends only on the field and not on the magnetization itself. Hence the goal may be described as building a numerical

magnetometer, capable of analyzing data close to the sample. This is in contrast to classical magnetometers which regard the latter as a single dipole, an approximation which is only valid away from the sample and is not suitable to handle weak fields which get quickly blurred by ambient magnetic sources. This research effort was paid in two different, complementary directions.

The first approach consists in computing asymptotic expansions of the integrals $\iint B_3(x_1, x_2, z) dx_1 dx_2$, $\iint x_1 B_3(x_1, x_2, z) dx_1 dx_2$ and $\iint x_2 B_3(x_1, x_2, z) dx_1 dx_2$, on several domains (namely, the 2-D balls of radius R for the 1, 2 and ∞ norm, that are squares, disks, diamonds), in terms of the moments of first and higher order of the magnetization m . Last year, we obtained formulas valid only under the thin-slab hypothesis. This year, we extended the results to the case of a volumetric magnetization. We posted a preprint [22] with these results on HAL, and our partners at MIT are currently conducting practical experiments with the SQUID to illustrate the method, before submitting it to some journal. In parallel, Fourier based techniques designed by reformulating the problem with the help of the Kelvin transform also furnish an asymptotic expansion of the net moment involving, at the first order, the above-mentioned integrals computed on disks of large radius. The computations are quite involved but allow to obtain higher-order terms. This constitutes Part III of D. Ponomarev's PhD work [11], defended this year.

The second approach attempts to generalize the previous expansions. The initial question is: given measurements of B_3 , find a function $\phi(x_1, x_2)$ such that $\iint \phi(x_1, x_2) B_3(x_1, x_2) dx_1 dx_2$ is best possible an estimate of the net moment components $\langle m_i \rangle$ ($i = 1, 2, 3$), in some appropriate sense. This problem has no solution really because, for any $\epsilon > 0$, there exists a function ϕ_ϵ allowing to estimate the moment with an error bounded by ϵ . We proved that, when ϵ tends to zero, the norm of the function ϕ_ϵ tends to infinity, which hinders an accurate numerical computation of the integral since B_3 is only known on a discrete grid of points. We therefore expressed the problem as a bounded extremal problem (see Section 3.3.1): to find the best ϕ_ϵ (with the smallest possible error value ϵ) under the constraint that $\|\nabla \phi_\epsilon\|_2 \leq M$. Here, M is a user-defined parameter. We improved on the iterative algorithm devised last year and completed the theoretical justification of its convergence. Basic properties of the operators involved, which are necessary to carry out the procedure, have been derived in [21], along with perspectives on minimum L^2 regularization for the computation of local moments (which are usually not determined by the field, unlike the net moment).

We also performed preliminary numerical experiments which are very encouraging, but still need to be pushed further in connection with the delicate issue of how dense should the grid of data points be in order to reach a prescribed level of precision. An article on this topic is in preparation.

In this connection, the PhD thesis of D. Ponomarev's [11], Part II, contains a study of the 2D spectral problem for the truncated Poisson operator in planar geometry. This is a simplified (*i.e.* 2-D) setup for the relation between the magnetization and the magnetic potential, of which the magnetic field is the gradient. It is relevant because, by the familiar Courant min-max principle, the eigenvectors of the magnetization-to-field operator produce in principle an efficient basis to expand a given magnetization in short series. Describing these eigenvectors is a long-standing problem. Asymptotic formulas as the measurement height gets small with respect to the size of the sample have been obtained, both for dominant eigenvalues and eigenvectors, through connections with other spectral problems. In fact, asymptotic reductions for large and small values of the main parameters (distance h from the measurement plane to the sample support and sample support size), yield approximate solutions by means of simpler integral equations and ODEs.

5.1.2. Inverse magnetization issues from sparse spherical data

The team Apics is a partner of the ANR project MagLune on Lunar magnetism, headed by the Geophysics and Planetology Department of Cerege, CNRS, Aix-en-Provence (see Section 7.2.2). Recent studies let geoscientists to think that the Moon used to have a magnetic dynamo for a while, yet the exact process that triggered and fed this dynamo is still not understood, much less why it stopped. The overall goal of the project is to devise models to explain how this dynamo phenomenon was possible on the Moon.

The geophysicists from Cerege went this year to NASA to perform measurements on a few hundreds of samples brought back from the Moon by Apollo missions. The samples are kept inside bags with a protective atmosphere, and geophysicists are not allowed to open the bags, nor to take out samples from NASA facilities.

Moreover, the process must be carried out efficiently as a fee is due to NASA by the time when handling these moon samples. Therefore, measurements were performed with some specific magnetometer designed by our colleagues from Cerege. This device measures the components of the magnetic field produced by the sample, at some discrete set of points located on circles belonging to three cylinders (see Figure 4). The objective of Apics is to enhance the numerical efficiency of post-processing data obtained with this magnetometer.

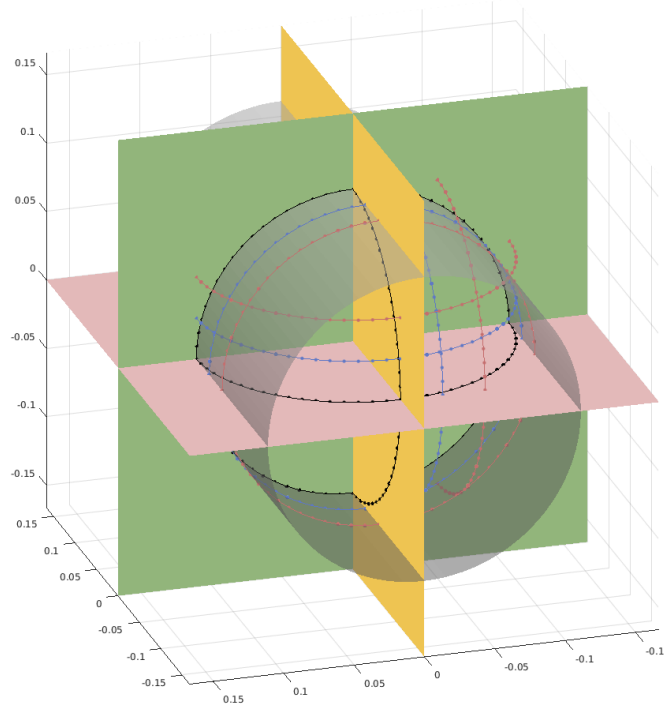

Figure 4. Typical measurements obtained with the instrument of Cerege. Measurements of the field are performed on nine circles, given as sections of three cylinders. On each circle, only one component of the field is measured: the component B_h along the axis of the corresponding cylinder (blue points), the component B_n radial with respect to the circle (black points), or the component B_τ tangential to the circle (red points).

This year, we continued the approach initiated in 2015 during K. Mavreas' internship: under the hypothesis that the field can be well explained by a single magnetic dipole, and using ideas similar to those underlying the FindSources3D tool (see Sections 3.4.2 and 5.1.5), we try to recover the position and moment of the dipole. The rational approximation technique that we are using gives, for each circle of measurements, a partial information about the position of the dipole. These partial informations obtained on all nine circles must then be combined in order to recover the exact position. Theoretically speaking, the nine partial informations are redundant and the position could be obtained by several equivalent techniques. But in practice, due to the fact that the field is not truly generated by a single dipole, and also because of noise in the measurements and numerical errors in the rational approximation step, all methods do not show the same reliability when combining the partial results. We studied several approaches, testing them on synthetic examples, with more or less noise, in order to propose a good heuristic for the reconstruction of the position. This is still on-going work.

5.1.3. Surface distributed magnetizations and vector fields decomposition

This is a joint work with Pei Dang and Tao Qian from the University of Macao.

Silent magnetizations in the thin plate case were characterized in [36] using a decomposition of \mathbb{R}^3 -valued vector fields defined on $\mathbb{R}^2 \sim \mathbb{R}^2 \times \{0\} \subset \mathbb{R}^3$. More precisely, in rather general smoothness classes (involving all distributions with compact support), such a vector field is the sum of the traces on \mathbb{R}^2 of a harmonic gradient in the upper half space, a harmonic gradient in the lower half space, and of a tangential divergence-free vector field. This year the corresponding decomposition has been obtained in L^p -classes on closed surfaces, where $1 < p < \infty$ if the surface is smooth but p has to be restricted around the value 2 if the surface is only Lipschitz smooth. The proof uses elliptic regularity theory, some Hodge theory and Clifford analysis.

In the case where the curvature is constant (*i.e.* for spheres and planes), one recovers using the previous result that silent distribution have no inner harmonic gradient component, whereas in the case of more general surfaces one finds they have to satisfy a spectral equation for the double layer potential. This also furnishes a characterization of volumetric silent distributions by saying that their balayage to the boundary of the volume (which is a closed surface) is silent. An article is being written on this topic.

5.1.4. Decomposition of the geomagnetic field

This is a joint work with Christian Gerhards from the University of Vienna.

The techniques based on solving bounded extremal problems, set forth in Section 5.1.1 to estimate the net moment of a planar magnetization, may be used to approach the problem of decomposing the magnetic field of the Earth into its crustal and core components, when adapted to a spherical geometry.

Indeed, in geomagnetism it is of interest to separate the Earth's core magnetic field from the crustal magnetic field. However, satellite measurements can only sense the superposition of the two contributions. In practice, the measured magnetic field is expanded in terms of spherical harmonics and a separation into crust and core contribution is done empirically by a sharp cutoff in the spectral domain. Under the assumption that the crustal magnetic field is supported on a strict subset of the Earth's surface, which is nearly verified as some regions on the globe are only very weakly magnetic, one can state an extremal problem to find a linear form yielding an arbitrary coefficient of the expansion in spherical harmonics on the crustal field, while being nearly zero on the core contribution. An article is being prepared to report on this research.

5.1.5. Inverse problems in medical imaging

This work is conducted in collaboration with Jean-Paul Marmorat and Nicolas Schnitzler, together with Maureen Clerc and Théo Papadopoulo from the Athena EPI.

In 3-D, functional or clinically active regions in the cortex are often modeled by pointwise sources that have to be localized from measurements, taken by electrodes on the scalp, of an electrical potential satisfying a Laplace equation (EEG, electroencephalography). In the works [6], [41] on the behavior of poles in best rational approximants of fixed degree to functions with branch points, it was shown how to proceed via best rational approximation on a sequence of 2-D disks cut along the inner sphere, for the case where there are finitely many sources (see Section 4.3).

In this connection, a dedicated software FindSources3D (see Section 3.4.2) is being developed, in collaboration with the team Athena and the CMA. In addition to the modular and ergonomic platform version of FindSources3D, a new (Matlab) version of the software that automatically performs the estimation of the quantity of sources is being built. It uses an alignment criterion in addition to other clustering tests for the selection. It appears that, in the rational approximation step, *multiple* poles possess a nice behavior with respect to branched singularities. This is due to the very physical assumptions on the model (for EEG data, one should consider *triple* poles). Though numerically observed in [7], there is no mathematical justification so far why multiple poles generate such strong accumulation of the poles of the approximants. This intriguing property, however, is definitely helping source recovery. It is used in order to automatically estimate the "most plausible" number of sources (numerically: up to 3, at the moment). Last but not least, this new version may take as inputs actual EEG measurements, like time signals, and performs a suitable singular value decomposition in order to separate independent sources.

In connection with these and other brain exploration modalities like electrical impedance tomography (EIT), we are now studying conductivity estimation problems. This is the topic of the PhD research work of C. Papageorgakis (co-advised with the Athena project-team and BESA GmbH). In layered models, it concerns the estimation of the conductivity of the skull (intermediate layer). Indeed, the skull was assumed until now to have a given isotropic constant conductivity, whose value can differ from one individual to another. A preliminary issue in this direction is: can we uniquely recover and estimate a single-valued skull conductivity from one EEG recording? This has been established in the spherical setting when the sources are known, see [14]. Situations where sources are only partially known and the geometry is more realistic than a sphere are currently under study. When the sources are unknown, we should look for more data (additional clinical and/or functional EEG, EIT, ...) that could be incorporated in order to recover both the sources locations and the skull conductivity. Furthermore, while the skull essentially consists of a hard bone part, which may be assumed to have constant electrical conductivity, it also contains spongy bone compartments. These two distinct components of the skull possess quite different conductivities. The influence of the second on the overall model is currently being studied.

5.2. Matching problems and their applications

Participants: Laurent Baratchart, Martine Olivi, David Martinez Martinez, Fabien Seyfert.

This is collaborative work with Stéphane Bila (XLIM, Limoges, France), Yohann Sence (XLIM, Limoges, France), Thierry Monediere (XLIM, Limoges, France), Francois Torrès (XLIM, Limoges, France) in the context of the ANR Cocoram (see Section 7.2.1).

Filter synthesis is usually performed under the hypothesis that both ports of the filter are loaded on a constant resistive load (usually 50 Ohm). In complex systems, filters are however cascaded with other devices, and end up being loaded, at least at one port, on a non purely resistive frequency varying load. This is for example the case when synthesizing a multiplexer: each filter is here loaded at one of its ports on a common junction. Thus, the load varies with frequency by construction, and is not purely resistive either. Likewise, in an emitter-receiver, the antenna is followed by a filter. Whereas the antenna can usually be regarded as a resistive load at some frequencies, this is far from being true on the whole pass-band. A mismatch between the antenna and the filter, however, causes irremediable power losses, both in emission and transmission. Our goal is therefore to develop a method for filter synthesis that allows us to match varying loads on specific frequency bands, while enforcing some rejection properties away from the pass-band.

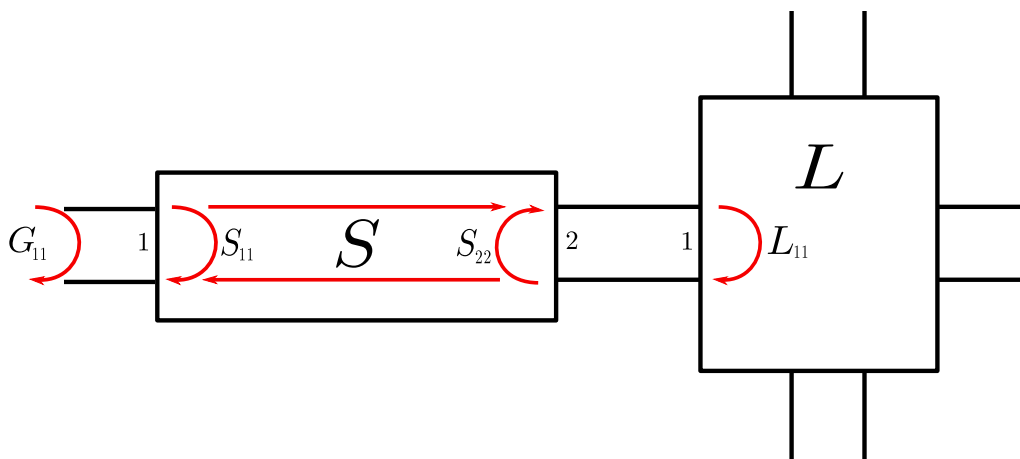

Figure 5. Filter plugged on a system with reflexion coefficient L_{11}

Figure 5 shows a filter with scattering matrix S , plugged at its right port on a frequency varying load with reflection parameter $L_{1,1}$. If the filter is lossless, simple algebraic manipulations show that on the frequency axis the reflex-ion parameter satisfies:

$$|G_{1,1}| = \left| \frac{S_{2,2} - \overline{L_{1,1}}}{1 - S_{2,2}L_{1,1}} \right| = \delta(G_{1,1}, S_{2,2}).$$

The matching problem of minimizing $|G_{1,1}|$ amounts therefore to minimize the pseudo-hyperbolic distance δ between the filter's reflex-ion parameter $S_{2,2}$ and the load's reflex-ion $L_{1,1}$, on a given frequency band. On the contrary enforcing a rejection level on a stop band, amounts to maintaining the value of $\delta(L_{1,1}, S_{2,2})$ above a certain threshold on this frequency band. For a broad class of filters, namely those that can be modeled by a circuit of n coupled resonators, the scattering matrix S is a rational function of McMillan degree n in the frequency variable. The matching problem thus appears to be a rational approximation problem in the hyperbolic metric.

5.2.1. Approach based on interpolation

When the degree n of the rational function $S_{2,2}$ is fixed, the hyperbolic minimization problem is non-convex which leads us to seek methods to derive good initial guesses for classical descent algorithms. To this effect, if $S_{2,2} = p/q$ where p, q are polynomials, we considered the following interpolation problem \mathcal{P} : given n frequency points $w_1 \cdots w_n$ and a transmission polynomial r , to find a monic polynomial p of degree n such that:

$$j = 1..n, \quad \frac{p}{q}(w_j) = \overline{L_{1,1}(w_j)}$$

where q is the unique monic Hurwitz polynomial of degree n satisfying the Feldtkeller equation

$$qq^* = pp^* + rr^*,$$

which accounts for the losslessness of the filter. The frequencies (w_k) are perfect matching points where $\delta(S_{2,2}(w_k), L_{1,1}(w_k)) = 0$ holds, while the real zeros (x_k) of r are perfect rejection points (i.e. $\delta(S_{2,2}(x_k), L_{1,1}(x_k)) = 1$). The interpolation problem is therefore a point-wise version of our original matching-rejection problem. The monic restriction on p and q ensures the realizability of the filter in terms of coupled resonating circuits. If a perfect phase shifter is added in front of the filter, realized for example with a transmission line on a narrow frequency band, these monic restrictions can be dropped and an extra interpolation point w_{n+1} is added, thereby yielding another interpolation problem $\widehat{\mathcal{P}}$. Our main result, states that \mathcal{P} as well as $\widehat{\mathcal{P}}$ admit a unique solution. Moreover the evaluation map defined by $\psi(p) = (p/q(x_1), \dots, p/q(x_n))$ is a homeomorphism from monic polynomials of degree n onto \mathbb{D}^n (\mathbb{D} the complex open disk), and ψ^{-1} is a diffeomorphism on an open, connected, dense set of \mathbb{D}^n . This last property has shown to be crucial for the design of an effective computational procedure based on continuation techniques. Current implementations of the latter tackle instances of \mathcal{P} or $\widehat{\mathcal{P}}$ for $n = 10$ in less than 0.1 *sec*, and allow for a recursive use of this interpolation framework in multiplexer synthesis problems. We presented these techniques at the MTNS conference 2016 held in Mineapolis [17]. The detailed mathematical proofs can be found in [23] which is under review at SIMA, the SIAM journal on Mathematical Analysis.

5.2.2. Uniform matching and global optimality considerations

The previous interpolation procedure provides us with a matching/rejecting filtering characteristics at a discrete set of frequencies. This may serve as a starting point for heavier optimization procedures, where the matching and rejection specifications are expressed uniformly over the bandwidth. Although the practical results thus obtained have shown to be quite convincing, we have no proof of their global optimality. This led us to seek alternative approaches able to assess, at least in simple cases, global optimality of the derived response. By optimality we mean, as in classical filtering, the ability to derive the uniformly best matching response in a given pass-band, while ensuring some rejection constraints on a stop-band. Following the approach of Fano and Youla, we considered the problem of designing a 2×2 loss-less frequency response, under the condition that a specified load can be "unchained" from one of its port. This classically amounts to set interpolation conditions on the response at the transmission zeros of the Darlington extension of the load. When the load admits a rational representation of degree 1, and if the transmission zeros of the overall system are fixed, then we were able to show that the uniform matching problem over an interval, together with rejection constraints at other frequency locations, reduces to a convex minimization problem with convex constraints over the set of non-negative polynomials of given degree. In this case, which is already of some practical interest for antenna matching (antennas usually exhibit a single resonance in their matching band which is decently approximated at order 1), it is therefore possible to perform filter synthesis with a guarantee on the global optimality of the obtained characteristics. The practical approach, relying on convex duality and linear programming is presented in [26], together with an implementation using a SIW (substrate integrated filter).

5.3. Sensitivities of Electrical Parameters with respect to physical parameters

Participants: Matthias Caenepel, Martine Olivi, Fabien Seyfert.

This work was conducted in collaboration with Yves Rolain (VUB, Brussels, Belgium). The goal is to automatize and improve our computer-aided tuning (CAT) method for coupled-resonator microwave synthesis, which is based on rational approximation and circuit extraction as explained before. The novelty here lies with estimating the Jacobian of the function that relates the physical filter design parameters to the extracted coupling parameters. Lately commercial full-wave electromagnetic (EM) simulators provide the adjoint sensitivities of the S-parameters with respect to the geometrical parameters. This information allows us for an efficient estimation of the Jacobian since it no longer requires finite difference based evaluation. Our tuning method first extracts the physically implemented coupling matrix, and then estimates the corresponding Jacobian. Next it compares the extracted coupling matrix to the target coupling matrix (golden goal). Using the difference between the coupling matrices and the pseudo-inverse of the estimated Jacobian, a correction that brings the design parameters closer to the golden goal is obtained. This process is repeated iteratively until the correction becomes sufficiently small with respect to a user-specified goal. In the case of coupling structures with multiple solutions, the Jacobian is calculated for each admissible solution. This paper presents a criterion to identify the physical solution among the different possibilities. The CAT method has been applied to the design of a cascaded triplet (CT) filter implemented in a microstrip technology. This filter is a well-known examples of a non-canonical coupling structure. See [24] for details.

5.4. Stability of amplifiers

Participants: Laurent Baratchart, Sylvain Chevillard, Martine Olivi, Fabien Seyfert, Sebastien Fueyo.

This work is performed under contract with CNES-Toulouse and the University of Bilbao as well as in collaboration with Adam Cooman (VUB, Brussels, Belgium). The goal is to help design amplifiers, in particular to detect instability at an early stage of the design. Activity in this area is gaining importance with the coming of a doctoral and a postdoctoral student along with planned software developments.

Performing a stability analysis during the design of any electronic circuit is critical to guarantee its correct operation. A closed-loop stability analysis can be performed by analyzing the impedance presented by the circuit at a well-chosen node without internal access to the simulator. If any of the poles of this impedance lie in the complex right half-plane, the circuit is unstable. The classic way to detect unstable poles is to fit a rational model on the impedance. This rational approximation has to deal with model order selection, which is difficult in circuits with transmission lines. In the practical approach we develop in collaboration with Adam Cooman, a projection-based method is proposed which splits the impedance into a stable and an unstable part by projecting on an orthogonal basis of stable and unstable functions. Working with a projection instead of a rational approximation greatly simplifies the stability analysis. When the projection is mapped from the complex plane to the unit disc, it boils down to calculating a Fourier series. If a significant part of the impedance is projected on the unstable part, a low-order rational approximation is fitted on this unstable part to find the location of the unstable poles. See [25] for details. Adapting such tools to check the stability of a trajectory, linearizing around the latter, is tantamount to develop a similar theory for time-varying periodic systems. This is the subject of S. Fueyo's PhD work.

5.5. Tools for numerically guaranteed computations

Participant: Sylvain Chevillard.

The overall and long-term goal is to enhance the quality of numerical computations. The software tool Sollya (see Section 3.4.5), developed together with C. Lauter (Université Pierre et Marie Curie) intends to provide an interactive environment for performing numerically rigorous computations. During year 2016, we released version 5.0 (in June) and version 6.0 (in October) of Sollya. Among other things, these releases have heavily improved the internal handling of polynomial expressions and the speed of the faithful evaluation of functions. They also make the library API more complete and fix most of the reported bugs. Another important novelty of 2016 is that Sollya is now officially included in the Debian Linux distribution.

5.6. Asymptotics of weighted Bergman polynomials

Participant: Laurent Baratchart.

We extended this year exterior asymptotics for orthonormal polynomials with respect to a weight on a planar region Ω (so-called weighted Bergman polynomials) to the case where Ω is simply connected, asymptotically conformal and chord arc, with exterior conformal map f from the complement of the disk to the complement of Ω such that f''/f' lies in a Hardy class H^q with $q < 1$. This class of domain is more general than, say the $C^{1\alpha}$ class. Meanwhile the weight should have integrable non-tangential maximal function and non-tangential limit with positive geometric mean. As $n \rightarrow \infty$, the formula reads

$$P_n(z) = \left(\frac{n+1}{\pi}\right)^{1/2} S_{w \circ f}(\Phi(z)) \Phi^n(z) \Phi'(z) \{1 + o(1)\},$$

locally uniformly outside the convex hull of Ω , where $\Phi = f^{-1}$ and $S_{w \circ f}$ is the Szegő function of the boundary weight. The proof uses quasi-conformal mappings and some Hardy space theory, along with classical Fourier analysis of Taylor sections.

The result goes much beyond those previously known, which either assume analyticity of Ω or else constant or analytic weight. An article is being written on this topic.

6. Bilateral Contracts and Grants with Industry

6.1. Contract CNES-Inria-XLIM

This contract (reference Inria: 7066, CNES: 127 197/00) involving CNES, XLIM and Inria, focuses on the development of synthesis algorithms for N -ports microwave devices. The objective is to derive analytical procedures for the design of multiplexers and routers, as opposed to "black box optimization" which is usually employed in this field (for $N \geq 3$). Emphasis at the moment bears on so-called "star-topologies".

6.2. Contract CNES-Inria-UPV/EHU

This contract (reference CNES: RS14/TG-0001-019) involving CNES, University of Bilbao (UPV/EHU) and Inria aims at setting up a methodology for testing the stability of amplifying devices. The work at Inria is concerned with the design of frequency optimization techniques to identify the unstable part of the linearized response and analyze the linear periodic components.

6.3. Contract BESA GmbH-Inria

This is a research agreement between Inria (Apics and Athena teams) and the German company BESA ², which deals with head conductivity estimation and co-advising of the doctoral work of C. Papageorgakis, see Section 5.1.5. BESA is funding half of the corresponding research grant, the other half is supported by Region PACA (BDO), see Section 1.

6.4. Flextronics

Flextronics, active in the manufacturing of communication devices all over the world, bought two sets of licenses for Presto-HF and Dedale-HF. Deployment of our tools in their production facilities for wireless communication units is being studied.

7. Partnerships and Cooperations

7.1. Regional Initiatives

- Contract Provence Alpes Côte d’Azur (PACA) Region - Inria, BDO (no. 2014-05764) funding the research grant of C. Papageorgakis, see Sections 5.1.5, 6.3.
- The team participates in the project WIMAG (Wave IMAGing) funded by the IDEX UCA-Jedi. It aims at identifying and gathering the research and development by partners of UCA involved in wave imaging systems. Other partners are UNS and CNRS (GéoAzur, I3S, LEAT, LJAD), together with Orange Labs.
- The team participates in the transversal action C4PO funded by the IDEX UCA-Jedi. This “Center for Planetary Origin” brings together scientists from various fields to advance and organize Planetary Science at the the University of Nice, and supports research and teaching initiatives within its framework.

7.2. National Initiatives

7.2.1. ANR COCORAM

The ANR (Astrid) project COCORAM (Co-design et co-intégration de réseaux d’antennes actives multi-bandes pour systèmes de radionavigation par satellite) started January 2014. We are associated with three other teams from XLIM (Limoges University), geared respectively towards filters, antennas and amplifiers design. The core idea of the project is to realize dual band reception an emission chains by co-conceiving the antenna, the filters, and the amplifier. We are specifically in charge of the theoretical design of the filters, matching the impedance of a bi-polarized dual band antenna. This is a perfect training ground to test, apply and adapt our work on matching problems (see Section 5.2).

²<http://www.besa.de/>

7.2.2. ANR MagLune

The ANR project MagLune (Magnétisme de la Lune) has been approved July 2014. It involves the Cerege (Centre de Recherche et d'Enseignement de Géosciences de l'Environnement, joint laboratory between Université Aix-Marseille, CNRS and IRD), the IGP (Institut de Physique du Globe de Paris) and ISTerre (Institut des Sciences de la Terre). Associated with Cerege are Inria (Apics team) and Irphe (Institut de Recherche sur les Phénomènes Hors Équilibre, joint laboratory between Université Aix-Marseille, CNRS and École Centrale de Marseille). The goal of this project (led by geologists) is to understand the past magnetic activity of the Moon, especially to answer the question whether it had a dynamo in the past and which mechanisms were at work to generate it. Apics participates in the project by providing mathematical tools and algorithms to recover the remanent magnetization of rock samples from the moon on the basis of measurements of the magnetic field it generates. The techniques described in Section 5.1 are instrumental for this purpose.

7.3. European Initiatives

7.3.1. Collaborations with Major European Organizations

Apics is part of the European Research Network on System Identification (ERNSI) since 1992.

System identification deals with the derivation, estimation and validation of mathematical models of dynamical phenomena from experimental data.

7.4. International Initiatives

7.4.1. Inria Associate Teams Not Involved in an Inria International Labs

7.4.1.1. IMPINGE

Title: Inverse Magnetization Problems IN GEosciences.

International Partner (Institution - Laboratory - Researcher):

Massachusetts Institute of Technology (United States) - Department of Earth, Atmospheric and Planetary Sciences - Benjamin P. Weiss

Start year: 2016

See also: <http://www-sop.inria.fr/apics/IMPINGE/>

The associate team IMPINGE is concerned with the inverse problem of recovering a magnetization distribution from measurements of the magnetic field above rock slabs using a SQUID microscope (developed at MIT). The application domain is to Earth and planetary sciences. Indeed, the remanent magnetization of rocks provides valuable information on their history. This is a renewal of the previous Associate Team IMPINGE that ended 2015. The US team also involves a group of Mathematicians (D. Hardin, M. Northington, E.B. Saff) at Vanderbilt University.

7.4.2. Inria International Partners

7.4.2.1. Declared Inria International Partners

MIT-France seed funding is a competitive collaborative research program ran by the Massachusetts Institute of Technology (Cambridge, Ma, USA). Together with E. Lima and B. Weiss from the Earth and Planetary Sciences dept. at MIT, Apics obtained two-years support from the above-mentioned program to run a project entitled: "Development of Ultra-high Sensitivity Magnetometry for Analyzing Ancient Rock Magnetism"

NSF Grant L. Baratchart, S. Chevillard and J. Leblond are external investigators in the NSF Grant 2015-2018, "Collaborative Research: Computational methods for ultra-high sensitivity magnetometry of geological samples" led by E.B. Saff (Vanderbilt Univ.) and B. Weiss (MIT).

7.5. International Research Visitors

7.5.1. Visits of International Scientists

- Christian Gerhards (Universität Wien, Vienna, Austria, September 5-9).
- Douglas Hardin (Vanderbilt University, Nashville, Tennessee, USA, June 11-21).
- Nuutti Hyvonen (Aalto University, Finland, June 13-14).
- Benjamin Lanfer (BESA, Munich, Germany, February 4-5).
- Eduardo Lima (MIT, Boston, Massachusetts, USA, June 13-17).
- Michael Northington (Vanderbilt University, Nashville, Tennessee, USA, June 11-22).
- Vladimir Peller (University of Michigan at East Lansing, June 10-24).
- Cristobal Villalobos (Vanderbilt University, Nashville, Tennessee, USA, June 8-21).

7.6. List of international and industrial partners

- Collaboration under contract with Thales Alenia Space (Toulouse, Cannes, and Paris), CNES (Toulouse), XLIM (Limoges), University of Bilbao (Universidad del País Vasco / Euskal Herriko Unibertsitatea, Spain), BESA company (Munich), Flextronics.
- Regular contacts with research groups at UST (Villeneuve d'Asq), Universities of Bordeaux-I (Talence), Orléans (MAPMO), Aix-Marseille (CMI-LATP), Nice Sophia Antipolis (Lab. JAD), Grenoble (IJF and LJK), Paris 6 (P. et M. Curie, Lab. JLL), Inria Saclay (Lab. Poems), Cerege-CNRS (Aix-en-Provence), CWI (the Netherlands), MIT (Boston, USA), Vanderbilt University (Nashville USA), Steklov Institute (Moscow), Michigan State University (East-Lansing, USA), Texas A&M University (College Station USA), Indiana University-Purdue University at Indianapolis, Politecnico di Milano (Milan, Italy), University of Trieste (Italy), RMC (Kingston, Canada), University of Leeds (UK), of Maastricht (the Netherlands), of Cork (Ireland), Vrije Universiteit Brussel (Belgium), TU-Wien and Universität Wien (Austria), TFH-Berlin (Germany), ENIT (Tunis), KTH (Stockholm), University of Cyprus (Nicosia, Cyprus), University of Macau (Macau, China), SIAE Microelettronica (Milano).
- The project is involved in the GDR-project AFHP (CNRS), in the ANR (Astrid program) project COCORAM (with XLIM, Limoges, and DGA), in the ANR (Défis de tous les savoirs program) project MagLune (with Cerege, IPGP, ISTerre, Irphe), in a MIT-France collaborative seed funding, in the Associate Inria Team IMPINGE (with MIT, Boston), and in a NSF grant (with Vanderbilt University and MIT).

8. Dissemination

8.1. Promoting Scientific Activities

- L. Baratchart gave a talk at the Shanks workshop “Mathematical methods for inverse magnetization problems arising in geosciences”, organized at Vanderbilt University (Nashville, USA), March 2016, a talk at “SEAM”, organized by the AMS at USF (Tampa, USA), a talk at “AppOpt” organized by ICIMAF in Havana (Cuba) <http://gama.uc3m.es/claroline1811/courses/APPOPT16/document/index.html> and a talk at ‘SIGMA’2016 (Signal-Image-Géométrie-Modélisation-Approximation). <http://programme-scientifique.weebly.com/1506.html>, organized by the SMAI at CIRM (Luminy, France).
- S. Chevillard gave a talk at the Shanks workshop “Mathematical methods for inverse magnetization problems arising in geosciences”, organized at Vanderbilt University (Nashville, USA), March 2016.

- B. Hanzon gave a presentation at the CDC 2016 pre-workshop on "realization theory and its role in system identification" (joint work with M. Olivi and R. Peeters) <https://sites.google.com/site/mihalypetreczky/workshop-cdc-2016>, Las-Vegas, USA, December 11.
- J. Leblond presented a communication at the above-mentioned Shanks Workshop, at the conference PICOF 2016 (Problèmes Inverses, Contrôle, Optimisation de Formes, Autrans, France, June 1-3 2016, <http://picof.sciencesconf.org/>), and at the seminar Mécanique, Modélisation Mathématique et Numérique, LMNO, Univ. Caen, France, December 5, 2016.
- M. Olivi gave a talk at the conference SIGMA'2016 (Signal-Image-Géométrie-Modélisation-Approximation). <http://programme-scientifique.weebly.com/1506.html>, Marseille, France, October 30-November 4.
- F. Seyfert presented a communication at the 22nd International Symposium on Mathematical Theory of Networks and Systems <https://sites.google.com/a/umn.edu/mtns-2016/>, USA, Minneapolis, July 12-15, 2016.
- K. Mavreas presented a communication at the Conference Advances in Lunar Magnetism: from Paleomagnetism to Dynamos, Cargèse, France, June 1-3, 2016, http://maglune.cerege.fr/?page_id=416. Together with C. Papageorgakis, they participated to the Semaine d'Étude Mathématiques-Informatique Entreprises, Grenoble, France, October 24-28, 2016. Grenoble.
- C. Papageorgakis presented a communication at the Conference PICOF 2016 and at the Science Day in BESA company, Munich, Germany, December 15, 2016.
- D. Ponomarev presented a communication at the above-mentioned Shanks Workshop and a poster at the Conference PICOF 2016.
- D. Martinez Martinez gave a seminar at the department ELEC of the Vrije Universiteit of Brussels (sept. 18) and at the Universidad Politécnica de Cartagena, ETSI (December 14). He gave a talk at the 2016 IEEE International Conference on Antenna Measurements & Applications, Syracuse (NY), USA, October 23-27.

8.1.1. Scientific Events Organisation

8.1.1.1. Member of the Organizing Committees

K. Mavreas and C. Papageorgakis were among the PhD students in charge of the PhD students Seminar within the Research Center.

J. Leblond was one of the co-organizers of the 3rd "Journée Mathématiques et Parité", IHP, Paris, July 8, 2016, <http://postes.smai.emath.fr/apres/parite/journee2016/>.

8.1.2. Scientific Events Selection

8.1.2.1. Member of the Conference Program Committees

L. Baratchart was a member of the program committee of "Mathematical Theory of Network and Systems" (MTNS) 2016, Minneapolis, Minnesota, USA.

J. Leblond was a member of the Scientific Committee of the Conference PICOF 2016.

8.1.3. Journal

8.1.3.1. Member of the Editorial Boards

L. Baratchart is sitting on the Editorial Board of the journals *Constructive Methods and Function Theory* and *Complex Analysis and Operator Theory*.

8.1.3.2. Reviewer - Reviewing Activities

L. Baratchart served as a reviewer for several journals (Annales Inst. Fourier, SIMA, Numerical Algorithms, Journal of Approx. Theory, Complex Variables and Elliptic Equations, ...)

J. Leblond was a reviewer for the journal *Multidimensional Systems and Signal Processing*, *Czechoslovak Mathematical Journal*.

M. Olivi was a reviewer for the journals *Automatica* and *IEEE Transactions on Automatic Control* and for the IEEE Conference on Decision and Control.

F. Seyfert was a reviewer for the journal *IEEE Microwave Theory and Techniques*.

8.1.4. Invited Talks

L. Baratchart was an invited speaker at the “25-th Summer Meeting in Mathematical Analysis”, organized by the Russian Academy of Sciences at the Euler Institute (St-Petersburg, Russia) <http://gauss40.pdmi.ras.ru/ma25/>, an invited speaker at the workshop “New Trends in Approximation Theory” organized by the CSM at the Fields Institute (Toronto, Canada) <http://www.fields.utoronto.ca/activities/16-17/approximation>, an invited speaker at the conference “Quasilinear equations, Inverse Problems and their Applications” organized by EAIP, RFBR, MIPT and Ecole Polytechnique at the Moscow Institute of Physics and Technology (Dolgoprundy, Russia) <http://www.cmap.polytechnique.fr/~novikov/miptip16/>, and an invited speaker at the “Complex Analysis Day” in Marne-la-Vallée.

S. Chevillard was invited to give a talk at the Fifth Approximation Days, International conference on constructive complex approximation, <http://math.univ-lille1.fr/~bbecker/ja2016/>, Lille, France, May 20, 2016.

J. Leblond was a plenary speaker at the Conference WiS&E 2016 (Waves in Sciences and Engineering), <http://qro.cinvestav.mx/index.php/wise2016>, Queretaro, Mexico, August 22-26, 2016, and an invited speaker at the Workshop SIGMA’2016 (Signal, Image, Geometry, Modelling, Approximation), <https://www.ceremade.dauphine.fr/~peyre/sigma2016/>, Luminy, France, October 31 - November 4, 2016.

F. Seyfert was invited to give a talk at the Workshop on Mathematical Aspects of Network Synthesis <http://www-control.eng.cam.ac.uk/Main/Workshop8>, Cambridge, UK, September 21-22, 2016.

8.1.5. Scientific Expertise

L. Baratchart is a member of the Mathematical panel of experts of ANR.

8.1.6. Research Administration

S. Chevillard was representative at the “comité de centre” and at the “comité des projets” (Research Center Inria-Sophia) until September 2016.

J. Leblond is an elected member of the “Conseil Scientifique” and of the “Commission Administrative Paritaire” of Inria. Until May, she was in charge of the mission “Conseil et soutien aux chercheurs” within the Research Center. She is also a member of the “Conseil Académique” of the Univ. Côte d’Azur (UCA).

8.2. Teaching - Supervision - Juries

8.2.1. Teaching

Colles: S. Chevillard is giving “Colles” at Centre International de Valbonne (CIV) (2 hours per week).

8.2.2. Supervision

PhD: D. Ponomarev, *Some inverse problems with partial data*, Université Nice Sophia Antipolis, defended on June 14, 2016 (advisors: J. Leblond, L. Baratchart).

PhD: M. Caenepeel, *The development of models for the design of RF/microwave filters*, Vrije Universiteit Brussel (VUB), defended on October 19, 2016 (advisors: Y. Rolain, M. Olivi, F. Seyfert).

PhD in progress: C. Papageorgakis, *Conductivity model estimation*, since October 2014 (advisors: J. Leblond, M. Clerc, B. Lanfer).

PhD in progress: K. Mavreas, *Inverse source problems in planetary sciences: dipole localization in Moon rocks from sparse magnetic data*, since October 2015 (advisors: S. Chevillard, J. Leblond).

PhD in progress: D. Martinez Martinez, *Méthodologie et Outils de Synthèse pour des Fonctions de Filtrage Chargées par des Impédances complexes*, since October 2015, advisors: L. Baratchart and F. Seyfert.

PhD in progress: G. Bose, *Filter Design to Match Antennas*, since December 2016, advisors: F. Ferrero and F. Seyfert.

PhD in progress: S. Fueyo, *Cycles limites et stabilité dans les circuits*, since October 2016, advisors: L. Baratchart and J.B. Pomet.

8.2.3. Juries

L. Baratchart sat on the PhD defense committee of d'Alexey Agaltsov (Ecole Polytechnique, <http://www.adum.fr/script/detailSout.pl?mat=65164&site=PSaclay>) and on the committee for the defense of *Habilitation à diriger des recherches* of E. Abakumov (Université Paris-Est, Marne-la-Vallée, <http://umr-math.univ-mlv.fr/evenements/soutenances/?type=101>).

J. Leblond was a member of the "Jury d'admissibilité du concours CR" of the Inria Research Center and of the "Comités de Sélection" for professors at UNSA (Polytech Nice) and at the University Paris-Sud Orsay (March-May 2016). She was a reviewer for the PhD thesis of Silviu Ioan Filip, Univ. Lyon, December 2016.

F. Seyfert was a member of the PhD jury of Adam Cooman at the ELEC. department of the VUB (Bruxelles, Belgium). The PhD's title is "Distorsion Analysis of Analog Electronic Circuits Using Modulated Signals".

8.3. Popularization

- M. Olivi is responsible for Scientific Mediation and president of the Committee MASTIC (Commission d'Animation et de Médiation Scientifique) <https://project.inria.fr/mastic/>. She animated two half-day workshop sessions "activités débranchées" at "l'ESPE de Nice" for primary school students (March 08 & 15), 200 students each session). She participates to the event "la fête de la science" in Nice (October 13) for scholars and in Antibes (October 22 & 23, 6200 people). She gave a talk "180'" at the "Journées Scientifiques Inria" in Rennes.
- K. Mavreas and C. Papageorgakis actively participated to events organized by the Committee MASTIC (Fête de la Science, ...).

9. Bibliography

Major publications by the team in recent years

- [1] S. AMARI, F. SEYFERT, M. BEKHEIT. *Theory of Coupled Resonator Microwave Bandpass Filters of Arbitrary Bandwidth*, in "Microwave Theory and Techniques, IEEE Transactions on", August 2010, vol. 58, n^o 8, pp. 2188 -2203
- [2] B. ATFEH, L. BARATCHART, J. LEBLOND, J. R. PARTINGTON. *Bounded extremal and Cauchy-Laplace problems on the sphere and shell*, in "J. Fourier Anal. Appl.", 2010, vol. 16, n^o 2, pp. 177–203, Published online Nov. 2009, <http://dx.doi.org/10.1007/s00041-009-9110-0>
- [3] L. BARATCHART, S. CHEVILLARD, T. QIAN. *Minimax principle and lower bounds in H^2 -rational approximation*, in "Journal of Approximation Theory", 2015, vol. 206, pp. 17–47

- [4] L. BARATCHART, J. LEBLOND, S. RIGAT, E. RUSS. *Hardy spaces of the conjugate Beltrami equation*, in "Journal of Functional Analysis", 2010, vol. 259, n^o 2, pp. 384-427, <http://dx.doi.org/10.1016/j.jfa.2010.04.004>
- [5] L. BARATCHART, F. MANDRÉA, E. B. SAFF, F. WIELONSKY. *2D inverse problems for the Laplacian: a meromorphic approximation approach*, in "Journal de Math. Pures et Appliquées", 2008, vol. 86, pp. 1-41
- [6] L. BARATCHART, H. STAHL, M. YATTSELEV. *Weighted Extremal Domains and Best Rational Approximation*, in "Advances in Mathematics", 2012, vol. 229, pp. 357-407, <http://hal.inria.fr/hal-00665834>
- [7] M. CLERC, J. LEBLOND, J.-P. MARMORAT, T. PAPADOPOULOU. *Source localization using rational approximation on plane sections*, in "Inverse Problems", May 2012, vol. 28, n^o 5, 24 p. , <http://hal.inria.fr/inria-00613644>
- [8] V. LUNOT, F. SEYFERT, S. BILA, A. NASSER. *Certified Computation of Optimal Multiband Filtering Functions*, in "IEEE Transactions on Microwave Theory and Techniques", 2008, vol. 56, n^o 1, pp. 105-112, <http://dx.doi.org/10.1109/TMTT.2007.912234>
- [9] M. OLIVI, F. SEYFERT, J.-P. MARMORAT. *Identification of microwave filters by analytic and rational H2 approximation*, in "Automatica", January 2013, vol. 49, n^o 2, pp. 317-325 [DOI : 10.1016/J.AUTOMATICA.2012.10.005], <http://hal.inria.fr/hal-00753824>

Publications of the year

Doctoral Dissertations and Habilitation Theses

- [10] M. CAENEPEEL. *Modeling technique for the efficient design of microwave bandpass filters*, Inria Sophia Antipolis - Méditerranée ; Vrije Universiteit Brussels, October 2016, <https://hal.archives-ouvertes.fr/tel-01421150>
- [11] D. PONOMAREV. *Some inverse problems with partial data*, Inria Sophia Antipolis - Méditerranée, June 2016, <https://hal.archives-ouvertes.fr/tel-01400595>

Articles in International Peer-Reviewed Journals

- [12] L. BARATCHART, A. BORICHEV, S. CHAABI. *Pseudo-holomorphic functions at the critical exponent*, in "Journal of the European Mathematical Society", 2016, vol. 18, n^o 9 [DOI : 10.4171/JEMS], <https://hal.inria.fr/hal-00824224>
- [13] L. BARATCHART, L. BOURGEOIS, J. LEBLOND. *Uniqueness results for inverse Robin problems with bounded coefficient*, in "Journal of Functional Analysis", 2016 [DOI : 10.1016/J.JFA.2016.01.011], <https://hal.inria.fr/hal-01084428>
- [14] M. CLERC, J. LEBLOND, J.-P. MARMORAT, C. PAPAGEORGAKIS. *Uniqueness result for an inverse conductivity recovery problem with application to EEG*, in "Rendiconti dell'Istituto di Matematica dell'Università di Trieste. An International Journal of Mathematics", 2016, vol. 48, Special issue dedicated to Giovanni Alessandrini, <https://hal.archives-ouvertes.fr/hal-01303640>
- [15] J. LEBLOND, D. PONOMAREV. *Recovery of harmonic functions in planar domains from partial boundary data respecting internal values*, in "Journal of Inverse and Ill-posed Problems", 2016 [DOI : 10.1515/JIIP-2015-0089], <https://hal.archives-ouvertes.fr/hal-01242160>

- [16] S. LEFTERIU, M. OLIVI, F. SEYFERT, M. OLDONI. *System identification of microwave filters from multiplexers by rational interpolation*, in "Automatica", August 2016, <https://hal.inria.fr/hal-01357934>

International Conferences with Proceedings

- [17] L. BARATCHART, M. OLIVI, F. SEYFERT. *A unified approach to Nevanlinna-Pick interpolation problems*, in "22nd International Symposium on Mathematical Theory of Networks and Systems", Minneapolis, United States, July 2016, <https://hal.archives-ouvertes.fr/hal-01420880>

Conferences without Proceedings

- [18] M. CLERC, J. LEBLOND, J.-P. MARMORAT, C. PAPAGEORGAKIS. *On some inverse conductivity recovery problem in a sphere: Uniqueness and reconstruction results with applications to EEG*, in "Problèmes Inverses, Contrôle et Optimisation de Formes (PICO)", Autrans, France, June 2016, <https://hal.inria.fr/hal-01410030>
- [19] J. LEBLOND, L. BARATCHART, S. CHEVILLARD, D. PONOMAREV. *Magnetic moments recovery from partial field measurements*, in "PICO (Problèmes Inverses, Contrôle, Optimisation de Formes)", Autrans, France, June 2016, <https://hal.archives-ouvertes.fr/hal-01413094>

- [20] D. MARTÍNEZ MARTÍNEZ, F. SEYFERT, M. OLIVI, J. SENCE, S. BILA, F. TORRES, T. MONÉDIÈRE, B. JARRY, A. PERIGAUD, B. FRIGUI, R. CHANTALAT. *Optimized synthesis of a microwave equalizer for matching a high performance small antenna*, in "2016 IEEE International Conference on Antenna Measurements & Applications", Syracuse, United States, October 2016, <https://hal.archives-ouvertes.fr/hal-01420641>

Other Publications

- [21] L. BARATCHART, S. CHEVILLARD, J. LEBLOND. *Silent and equivalent magnetic distributions on thin plates*, September 2016, Accepted for publication in Theta Series in Advanced Mathematics, <https://hal.inria.fr/hal-01286117>
- [22] L. BARATCHART, S. CHEVILLARD, J. LEBLOND, E. A. LIMA, D. PONOMAREV. *Moments estimation of magnetic source terms from partial data*, 2016, working paper or preprint, <https://hal.inria.fr/hal-01421157>
- [23] L. BARATCHART, M. OLIVI, F. SEYFERT. *Boundary nevanlinna-pick interpolation with prescribed peak points. Application to impedance matching*, October 2016, Submitted for publication to SIMA (SIAM journal on Mathematical Analysis) July 2016, <https://hal.inria.fr/hal-01377782>
- [24] M. CAENEPEEL, F. SEYFERT, M. OLIVI, Y. ROLAIN. *Electromagnetic Optimization of Microwave Filters using Adjoint Sensitivities*, December 2016, submitted to Transactions on Microwave Theory and Techniques, <https://hal.inria.fr/hal-01419500>
- [25] A. COOMAN, F. SEYFERT, M. OLIVI, S. CHEVILLARD, L. BARATCHART. *Model-Free Closed-Loop Stability Analysis: A Linear Functional Approach*, October 2016, Preprint of the version submitted to IEEE Transactions on Microwave Theory and Techniques, <https://hal.inria.fr/hal-01381731>
- [26] D. MARTÍNEZ MARTÍNEZ, F. SEYFERT, M. OLIVI, S. BILA, F. TORRES, J. SENCE. *Synthesis Method for Matching Filters*, December 2016, working paper or preprint, <https://hal.archives-ouvertes.fr/hal-01420636>

References in notes

- [27] N. I. ACHESER. *Elements of the Theory of Elliptic Functions*, AMS, 1990
- [28] D. ALPAY, L. BARATCHART, A. GOMBANI. *On the Differential Structure of Matrix-Valued Rational Inner Functions*, in "Operator Theory : Advances and Applications", 1994, vol. 73, pp. 30–66
- [29] J. A. BALL, I. GOHBERG, L. RODMAN. *Interpolation of rational matrix functions*, Birkhäuser, 1990
- [30] L. BARATCHART. *A remark on uniqueness of best rational approximants of degree 1 in L^2 of the circle*, in "Elec. Trans.on Numerical Anal.", 2006, vol. 25, pp. 54–66
- [31] L. BARATCHART. *On the H^2 Rational Approximation of Markov Matrix-Valued Functions*, in "Proc. 17th Symposium on Mathematical Theory of Networks and Systems (MTNS)", Kyoto, Japon, 2006, pp. 180–182
- [32] L. BARATCHART, M. CARDELLI, M. OLIVI. *Identification and rational L^2 approximation: a gradient algorithm*, in "Automatica", 1991, vol. 27, pp. 413–418
- [33] L. BARATCHART, M. CHYBA, J.-B. POMET. *A Grobman-Hartman theorem for control systems*, in "J. Dyn. Differential Eqs.", 2007, vol. 19, pp. 75-107
- [34] L. BARATCHART, Y. FISCHER, J. LEBLOND. *Dirichlet/Neumann problems and Hardy classes for the planar conductivity equation*, in "Complex Variables and Elliptic Equations", 2014, 41 p. [DOI : 10.1080/17476933.2012.755755], <https://hal.archives-ouvertes.fr/hal-00909577>
- [35] L. BARATCHART, L. GOLINSKII, S. KUPIN. *Orthogonal rational functions and nonstationary stochastic processes: a Szegő theory*, in "Proc. 19th Symposium on Mathematical Theory of Networks and Systems", Budapest, 2010
- [36] L. BARATCHART, D. HARDIN, E. A. LIMA, E. B. SAFF, B. WEISS. *Characterizing kernels of operators related to thin-plate magnetizations via generalizations of Hodge decompositions*, in "Inverse Problems", 2013, vol. 29, n^o 1 [DOI : 10.1088/0266-5611/29/1/015004], <http://hal.inria.fr/hal-00919261>
- [37] L. BARATCHART, R. KUESTNER, V. TOTIK. *Zero distributions via orthogonality*, in "Annales de l'Institut Fourier", 2005, vol. 55, n^o 5, pp. 1455–1499
- [38] L. BARATCHART, S. KUPIN, V. LUNOT, M. OLIVI. *Multipoint Schur algorithm and orthogonal rational functions: convergence properties, I*, in "Journal d'Analyse", 2011, vol. 112, pp. 207-255, <http://arxiv.org/abs/0812.2050v3>
- [39] L. BARATCHART, J. LEBLOND. *Hardy approximation to L^p functions on subsets of the circle with $1 \leq p < \infty$* , in "Constructive Approximation", 1998, vol. 14, pp. 41–56
- [40] L. BARATCHART, J. LEBLOND, F. MANDRÉA, E. B. SAFF. *How can meromorphic approximation help to solve some 2D inverse problems for the Laplacian?*, in "Inverse Problems", 1999, vol. 15, n^o 1, pp. 79–90, <http://dx.doi.org/10.1088/0266-5611/15/1/012>

- [41] L. BARATCHART, J. LEBLOND, J.-P. MARMORAT. *Sources identification in 3D balls using meromorphic approximation in 2D disks*, in "Electronic Transactions on Numerical Analysis (ETNA)", 2006, vol. 25, pp. 41–53
- [42] L. BARATCHART, J. LEBLOND, J. R. PARTINGTON. *Hardy approximation to L^∞ functions on subsets of the circle*, in "Constructive Approximation", 1996, vol. 12, pp. 423–435
- [43] L. BARATCHART, J. LEBLOND, F. SEYFERT. *Extremal problems of mixed type in H^2 of the circle*, Inria, 2009, n^o RR-7087, <http://fr.arxiv.org/abs/0911.1441>
- [44] L. BARATCHART, F. MANDRÉA, E. B. SAFF, F. WIELONSKY. *2D inverse problems for the Laplacian: a meromorphic approximation approach*, in "Journal de Math. Pures et Appliquées", 2008, vol. 86, pp. 1-41
- [45] L. BARATCHART, M. OLIVI. *Index of critical points in l^2 -approximation*, in "System and Control Letters", 1988, vol. 10, pp. 167–174
- [46] L. BARATCHART, M. OLIVI. *Critical points and error rank in best H^2 matrix rational approximation of fixed McMillan degree*, in "Constructive Approximation", 1998, vol. 14, pp. 273–300
- [47] L. BARATCHART, E. B. SAFF, F. WIELONSKY. *A criterion for uniqueness of a critical point in H^2 rational approximation*, in "Journal d'Analyse", 1996, vol. 70, pp. 225–266
- [48] L. BARATCHART, F. SEYFERT. *An L^p analog to AAK theory for $p \geq 2$* , in "Journal of Functional Analysis", 2002, vol. 191, n^o 1, pp. 52–122
- [49] L. BARATCHART, H. STAHL, F. WIELONSKY. *Asymptotic uniqueness of best rational approximants of given degree to Markov functions in L^2 of the circle*, in "Constr. Approx.", 2001, vol. 17, n^o 1, pp. 103–138
- [50] L. BARATCHART, M. YATTSELEV. *Convergent interpolation to Cauchy integrals over analytic arcs*, in "Found. Comp. Math.", 2009, vol. 9, n^o 6, pp. 675–715
- [51] L. BARATCHART, M. YATTSELEV. *Meromorphic approximants for complex Cauchy transforms with polar singularities*, in "Mat. Sbornik", 2009, vol. 200, n^o 9, pp. 3-40
- [52] L. BARATCHART, M. YATTSELEV. *Asymptotic uniqueness of best rational approximants to complex Cauchy transforms in L^2 of the circle*, in "Recent trends in orthogonal polynomials and approximation theory", Providence, RI, Contemp. Math., Amer. Math. Soc., 2010, vol. 507, pp. 87–111
- [53] L. BARATCHART, M. YATTSELEV. *Convergent Interpolation to Cauchy Integrals over Analytic Arcs with Jacobi-Type Weights*, in "International Mathematics Research Notices", 2010, vol. 2010, n^o 22, pp. 4211–4275, <http://hal.inria.fr/hal-00508314>
- [54] A. BEN ABDA, F. BEN HASSEN, J. LEBLOND, M. MAHJOUB. *Sources recovery from boundary data: a model related to electroencephalography*, in "Mathematical and Computer Modelling", 2009, vol. 49, n^o 11–12, pp. 2213–2223, <http://dx.doi.org/10.1016/j.mcm.2008.07.016>
- [55] R. CAMERON, J.-C. FAUGÈRE, F. ROUILLIER, F. SEYFERT. *Exhaustive approach to the coupling matrix synthesis problem and application to the design of high degree asymmetric filters*, in "International Journal

- of RF and Microwave Computer-Aided Engineering", 2007, vol. 17, n^o 1, pp. 4–12, <http://hal.inria.fr/hal-00663777>
- [56] R. CAMERON, A. HARISH, C. RADCLIFFE. *Synthesis of advanced microwave filters without diagonal cross-couplings*, in "IEEE Transactions on Microwave Theory and Techniques", dec 2002, vol. 50, n^o 12, pp. 2862–2872, <http://dx.doi.org/10.1109/TMTT.2002.805141>
- [57] S. CHAABANE, I. FELLAH, M. JAOUA, J. LEBLOND. *Logarithmic stability estimates for a Robin coefficient in 2D Laplace inverse problems*, in "Inverse Problems", 2004, vol. 20, n^o 1, pp. 49–57, <http://dx.doi.org/10.1088/0266-5611/20/1/003>
- [58] S. CHAABI. *Analyse complexe et problèmes de Dirichlet dans le plan : équation de Weinstein et autres conductivités non bornées*, Mathématiques et Informatique de Marseille, 2013
- [59] R. COIFMAN, R. ROCHBERG, G. WEISS. *Factorization theorems for Hardy spaces in several variables*, in "Ann. Math.", 1976, vol. 103, pp. 611–635
- [60] Y. FISCHER. *Approximation des des classes de fonctions analytiques généralisées et résolution de problèmes inverses pour les tokamaks*, Univ. Nice Sophia Antipolis, 2011, <http://tel.archives-ouvertes.fr/tel-00643239/>
- [61] A. FRIEDMAN, M. VOGELIUS. *Determining cracks by boundary measurements*, in "Indiana Univ. Math. J.", 1989, vol. 38, n^o 3, pp. 527–556
- [62] P. FULCHERI, M. OLIVI. *Matrix rational H^2 -approximation: a gradient algorithm based on Schur analysis*, in "SIAM J. on Control & Optim.", 1998, vol. 36, pp. 2103–2127
- [63] J. B. GARNETT. *Bounded analytic functions*, Academic Press, 1981
- [64] T. GEORGIU. *A topological approach to Nevanlinna-Pick interpolation*, in "SIAM J. Math. Anal.", 1987, vol. 18, n^o 5, pp. 1248–1260
- [65] B. HANZON, M. OLIVI, R. L. PEETERS. *Balanced realizations of discrete-time stable all-pass systems and the tangential Schur algorithm*, in "Linear Algebra and its Applications", 2006, vol. 418, pp. 793-820, <http://dx.doi.org/10.1016/j.laa.2006.09.029>
- [66] J. HELTON, D. MARSHALL. *Frequency domain analysis and analytic selections*, in "Indiana Univ. Math. J.", 1990, vol. 39, n^o 1, pp. 157–184
- [67] T. IWANIEC, G. MARTIN. *Geometric function theory and non-linear analysis*, Oxford Univ. Press, 2001
- [68] B. JACOB, J. LEBLOND, J.-P. MARMORAT, J. R. PARTINGTON. *A constrained approximation problem arising in parameter identification*, in "Linear Algebra and its Applications", 2002, vol. 351-352, pp. 487-500
- [69] N. LANDKHOFF. *Foundations of modern potential theory*, Springer-Verlag, 1972
- [70] M. LAVRENTIEV. *Some Improperly Posed Problems of Mathematical Physics*, Springer, 1967

-
- [71] J.-P. MARMORAT, M. OLIVI. *Nudelman Interpolation, Parametrization of Lossless Functions and balanced realizations*, in "Automatica", 2007, vol. 43, pp. 1329–1338, <http://dx.doi.org/10.1016/j.automatica.2007.01.020>
- [72] H. ORCHARD, G. TEMES. *Filter Design Using Transformed Variables*, in "IEEE Transactions on Circuit Theory", dec 1968, vol. 15, n^o 4, pp. 385–408, <http://dx.doi.org/10.1109/TCT.1968.1082870>
- [73] V. PELLER. *Hankel Operators and their Applications*, Springer, 2003
- [74] A. SCHNECK. *Constrained Hardy space approximation*, in "J. Approx. Theory", 2010, vol. 8, pp. 1466–1483
- [75] I. SCHUR. *Über Potenzreihen die im innern des einheitskreises beschränkt sind*, in "J. Reine Angew. Math.", 1917, vol. 147, pp. 205–232
- [76] F. SEYFERT, L. BARATCHART, J.-P. MARMORAT, S. BILA, J. SOMBRIN. *Extraction of coupling parameters for microwave filters: determinati on of a stable rational model from scattering data*, in "2003 IEEE MTT-S International Microwave Symposium Digest", Philadelphie, États-Unis, IEEE, 2003, vol. 1, pp. 25–28, <http://hal.inria.fr/hal-00663504>
- [77] E. M. STEIN. *Harmonic Analysis*, Princeton University Press, 1993
- [78] A. SUÀREZ, R. QUÉRÉ. *Stability analysis of nonlinear microwave circuits*, Artech House, 2003
- [79] T. WOLFF. *Counterexamples with harmonic gradients in \mathbf{R}^3* , in "Essays on Fourier analysis in honor of Elias M. Stein", Math. Ser., Princeton Univ. Press, 1995, vol. 42, pp. 321–384