



RESEARCH CENTER

FIELD

**Applied Mathematics, Computation
and Simulation**

Activity Report 2014

Section New Results

Edition: 2015-03-24

NUMERICAL SCHEMES AND SIMULATIONS

1. BACCHUS Team 5
2. CAGIRE Team 8
3. DEFI Project-Team 11
4. ECUADOR Project-Team 17
5. GAMMA3 Project-Team 21
6. IPSO Project-Team 25
7. MATHERIALS Team 33
8. MC2 Team 39
9. MEPHYSTO Team 42
10. MOKAPLAN Team 44
11. NACHOS Project-Team 47
12. NANO-D Project-Team 51
13. OPALE Project-Team 62
14. POEMS Project-Team 70

OPTIMIZATION AND CONTROL OF DYNAMIC SYSTEMS

15. APICS Project-Team 77
16. BIPOP Project-Team 86
17. COMMANDS Project-Team 92
18. CORIDA Team 98
19. DISCO Project-Team 101
20. GECO Project-Team 108
21. I4S Project-Team 113
22. Maxplus Project-Team 121
23. MCTAO Project-Team 142
24. NECS Project-Team 144
25. NON-A Project-Team 151
26. QUANTIC Team 157

OPTIMIZATION, MACHINE LEARNING AND STATISTICAL METHODS

27. CLASSIC Project-Team 161
28. DOLPHIN Project-Team 162
29. GEOSTAT Project-Team 165
30. MISTIS Project-Team 172
31. MODAL Project-Team 182
32. REALOPT Project-Team 186
33. SELECT Project-Team 190
34. SEQUEL Project-Team 195
35. SIERRA Project-Team 204
36. TAO Project-Team 209

STOCHASTIC APPROACHES

37. ASPI Project-Team 214

38. CQFD Project-Team	217
39. MATHRISK Project-Team	227
40. REGULARITY Project-Team	232
41. TOSCA Project-Team	236

BACCHUS Team

5. New Results

5.1. Penalisation methods using unstructured meshes

Participants: Heloise Beaugendre [Corresponding member], Cécile Dobrzynski, Leo Nouveau, Quentin Viville.

In Computational Fluid Dynamics the interest on embedded boundary methods for Navier-Stokes equations increases because they simplify the meshing issue, the simulation of multi-physics flows and the coupling of fluid-solid interactions in situation of large motions or deformations. Nevertheless an accurate treatment of the wall boundary conditions remains an issue of these methods. In this work we develop an immersed boundary method for unstructured meshes based on a penalization technique and we use mesh adaption to improve the accuracy of the method close to the boundary. The idea is to combine the strength of mesh adaptation, that is to provide an accurate flow description especially when dealing with wall boundary conditions, to the simplicity of embedded grids techniques, that is to simplify the meshing issue and the wall boundary treatment when combined with a penalization term to enforce boundary conditions. The bodies are described using a level-set method and are embedded in an unstructured grid. Once a first numerical solution is computed mesh adaptation based on two criteria the level-set and the quality of the solution is performed. The full paper has been published in the Journal of Computational Physics in January 2014.

External contributors. This work has benefitted from the collaboration with the University of Zurich, and in particular with R. Abgrall.

5.2. Mesh adaptation by continuous deformation

Participants: Luca Arpaia, Mario Ricchiuto [Corresponding member].

As discussed in section 3.3 Meshes and scalable discrete data structures an accurate resolution of time dependent flows requires a dynamic mesh adaptation procedure which is quite complex and costly, especially when combined with parallel distributed memory implementations. To alleviate this cost, and still allow mesh adaptation for time dependent problems we have started to look into adaptation techniques which do not involve any re-meshing. In particular, we have studied methods based on continuous mesh deformation. These methods require, at each time step, the solution of a PDE for the mesh as well as for the flow variables. This year we have settled several fundamental questions related to the basic formulation of the method, and its coupling with either implicit or explicit time discretisation methods of the flow variables. Initial applications to free surface flows have been considered showing the generality and potential of our results [39].

5.3. Non-hydrostatic modelling of free surface flows

Participants: Stevan Bellec, Mathieu Colin [Corresponding member], Andrea Filippini, Maria Kazolea, Mario Ricchiuto.

This year we have made a lot of progress in the understanding of the properties of Boussinesq-type models for near shore applications. In particular, we have performed a systematic analysis of the nonlinear behaviour of these models in the surf-zone, and in particular of their shoaling properties. These properties influence fundamentally the wave breaking process, and thus the impact of the wave on coastal structures. We have clearly identified two families of physical behaviours, associated to a similar formal structure of the equations. This result has been presented in [30], [45], and the full study is currently in revision on the Coastal Engineering journal.

In parallel, we have continued the study of the implementation of wave breaking models, comparing several physical criteria for the detection of the beginning and end of the breaking process. So far, we have only tested the so-called hybrid approach in which the hyperbolic Shallow Water equations are used in breaking regions, and the energy dissipation of breaking waves is modelled by the dissipation of mathematical entropy in shock waves. The work performed complements the initial study performed by M. Kazolea in her PhD and also proposes new physical detection criteria [28], [44] (a full paper is in preparation).

Furthermore, we have began a systematic study on the existence of particular solutions (such as solitary waves for example) to the different Boussinesq-type models in view of having efficient materials to determinate the efficiency of our numerical schemes and to perform preliminary simulations.

The last important theoretical brick we added this year is the study of fully discrete asymptotic models, obtained by pre-discretizing the two-dimensional incompressible free surface Euler equations with a finite element method, and then by performing an asymptotic development (in terms of the classical nonlinearity and dispersion parameters). We have thus obtained a discrete model which, although consistent with a known continuous Boussinesq system, represents a surprisingly improved discret eversion of these equations, hardly obtainable by classical discretisation choices.

Besides the modelling effort, we have also started woking on real applications. In particular, we have worked on case studies involving harbour dynamics and river hydraulics. In the first case, M. Kazolea has performed a systematic study of the contribution of harbour resonance in the excitation of the Venetian harbor basin of Chania, during typical winder storms. Concerning river hydraulics, we have performed a parametric study of the appearance of tidal bores in estuaries, with parameters given by the tide non-linearity (amplitude), and the friction in the river. Both works will be presented at the next world congress of the International Association for Hydro-Environment Engineering.

External contributors. This work has benefitted from the collaboration with the EPOC lab in Bordeaux, and in particular with P. Bonneton.

5.4. Two-phase flow numerical simulation with real-gas effects and occurrence of rarefaction shock waves

Participants: Maria Giovanna Rodio, Pietro Marco Congedo [Corresponding member].

A discrete equation method (DEM) for the simulation of compressible multiphase flows including real-gas effects has been developed. A reduced five equation model is obtained starting from the semi-discrete numerical approximation of the two-phase model. A simple procedure is then proposed for using a more complex equation of state, thus improving the quality of the numerical prediction. Classical test-cases well-known in literature are performed featuring a strong importance of thermodynamic complexity for a good prediction of temperature evolution. Finally, a computational study on the occurrence of rarefaction shock waves (RSW) in a two-phase shock tube is presented, with dense vapors of complex organic fluids. Since previous studies have shown that a RSW is relatively weak in a single-phase (vapor) configuration, its occurrence and intensity are investigated considering the influence of the initial volume fraction, initial conditions and the thermodynamic model [11]. A transition modelling has been also introduced for considering heat and mass transfer terms. In this way, metastable states have been simulated in cavitating flows Finally, a semi-intrusive stochastic technique has been formulated for taking into account uncertainties in the simulation of metastable states.

External contributors. This work has benefitted from the collaboration with the University of Zurich, and in particular with R. Abgrall.

5.5. Formulation of stochastic methods for CFD

Participants: Gianluca Geraci, Kunkun Tang, Francesca Fusi, Pietro Marco Congedo [Corresponding member].

A novel adaptive strategy for stochastic problems has been developed, inspired from the classical Harten's framework. The proposed algorithm allows building, in a very general manner, stochastic numerical schemes starting from a whatever type of deterministic schemes and handling a large class of problems, from unsteady to discontinuous solutions. Its formulations permits to recover the same results concerning the interpolation theory of the classical multiresolution approach, but with an extension to uncertainty quantification problems. The present strategy permits to build numerical scheme with a higher accuracy with respect to other classical uncertainty quantification techniques, but with a strong reduction of the numerical cost and memory requirements. Moreover, the flexibility of the proposed approach allows to employ any kind of probability density function, even discontinuous and time varying, without introducing further complications in the algorithm. The advantages of the present strategy are demonstrated by performing several numerical problems where different forms of uncertainty distributions are taken into account, such as discontinuous and unsteady custom-defined probability density functions. In addition to algebraic and ordinary differential equations, numerical results for the challenging 1D Kraichnan–Orszag are reported in terms of accuracy and convergence. Finally, a two degree-of-freedom aeroelastic model for a subsonic case is presented. Though quite simple, the model allows recovering some physical key aspect, on the fluid/structure interaction, thanks to the quasi-steady aerodynamic approximation employed. The injection of an uncertainty is chosen in order to obtain a complete parameterization of the mass matrix. All the numerical results are compared with respect to classical Monte Carlo solution and with a non-intrusive Polynomial Chaos method [3].

Moreover, in [15], an anchored ANOVA method is proposed to decompose statistical moments. Compared to standard ANOVA with mutually orthogonal components, anchored ANOVA, with arbitrary anchor point, loses orthogonality if employing the same measure. However, an advantage consists in the considerably reduced number of deterministic solver's computations, which renders uncertainty quantification of real engineering problems much easier. Different from existing methods, covariance decomposition of output variance is used in this paper to take account of interactions between non-orthogonal components, yielding an exact variance expansion, and thus, with a suitable numerical integration method, provides a strategy that converges. This convergence is verified by studying academic tests. In particular, sensitivity problem of existing method to anchor point is analyzed via Ishigami case, and we point out covariance decomposition survives from it. Covariance-based sensitivity indices (SI) are also used, compared to variance-based SI. Furthermore, we emphasize covariance decomposition can be generalized in a straightforward way to decompose high order moments. For academic problems, results show the method converges to exact solution regarding both skewness and kurtosis. Finally, the proposed method is applied on a realistic case, i.e. estimating chemical reactions uncertainties in a hypersonic flow around a space vehicle during an atmospheric reentry.

External contributors. This work has benefitted from the collaboration with the University of Zurich, and in particular with R. Abgrall.

CAGIRE Team

6. New Results

6.1. DNS of a Taylor Green vortex

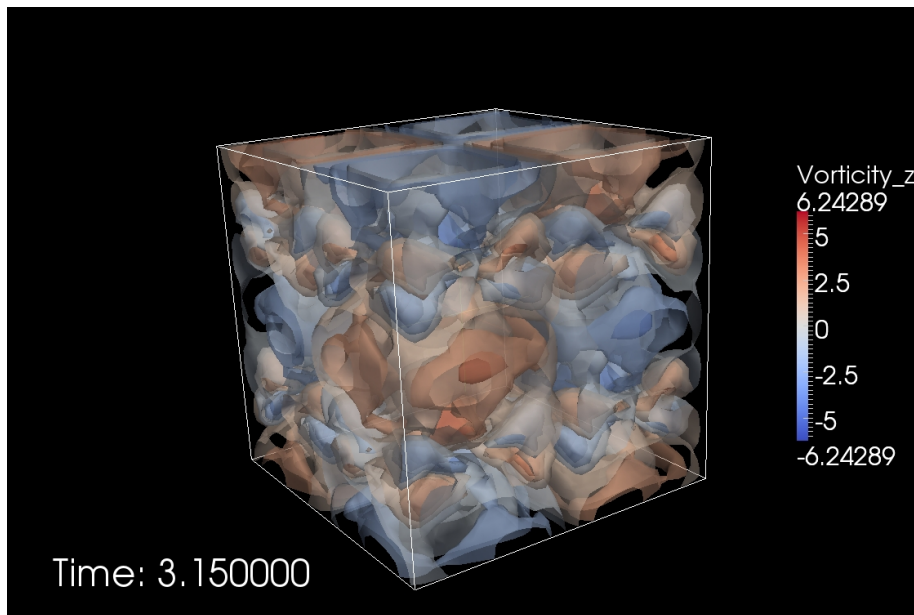

Figure 3. AeroSol simulation of a Taylor-Green vortex: snapshot of one component of the vorticity.

In 2014, we finished the validation of Navier-Stokes discretization with the discontinuous Galerkin method in the Aerosol library. The result of Figure 3 is a first validation in turbulence conditions. The Taylor-Green vortex case is part of the C3 (i.e. "difficult") test cases of the high order CFD workshop, see <https://www.grc.nasa.gov/hiocfd/>.

6.2. Low Mach number flows simulations issues

Our activity for developing schemes suitable for the simulation of low Mach number flows considers the two main techniques developed initially for dealing with either zero Mach number flows (pressure-velocity coupling) or compressible flows (density based approach). For both approaches, we concentrated this year on the specific difficulties related to unsteady flows simulations. For the methodology addressing the pressure-velocity coupling with a low-order discretization technique, we introduced an inertia term in the AUSM+ -up scheme. The resulting scheme, called AUSM-IT (IT for Inertia Term), was designed as an extension of the AUSM+ -up scheme allowing for full Mach number range calculations of unsteady flows including acoustic features. In line with the continuous asymptotic analysis, the AUSM-IT scheme satisfies the conservation of the discrete linear acoustic energy at first order in the low Mach number limit. Its capability to properly handle low Mach number unsteady flows, that may include acoustic waves or discontinuities was numerically illustrated [7].

As far as density based approach are concerned, an analysis of explicit RKDG schemes have been performed for unstationary acoustic waves propagating in a low Mach number flow. Classical cures of the unaccuracy of upwind schemes at low Mach number consist in using centered flux on the pressure. By a two scale asymptotic expansion of the scheme, we proved that this cure is a dead end for resolving unstationary acoustic waves, because it leads to a non dissipative scheme for the wave equations. We developed a dissipative term that can both stabilize the stationary incompressible equations, and the system of acoustic waves. The results with this new type of scheme have been presented in [8].

6.3. Improving the flexibility of turbulence models for industrial applications

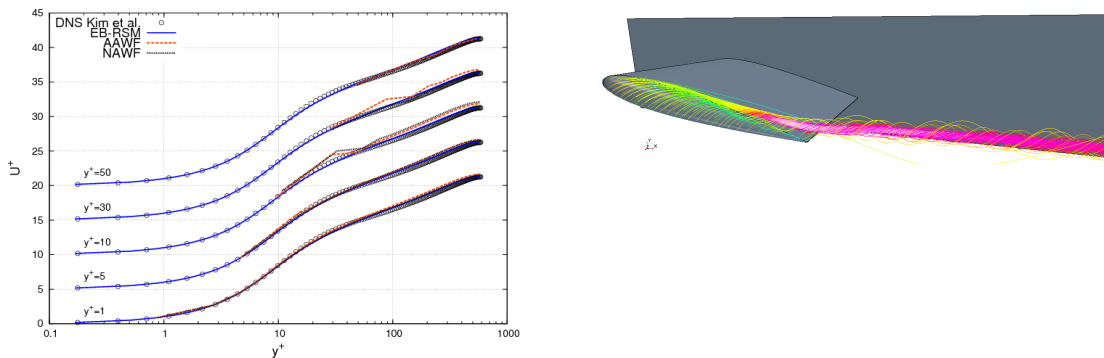

Figure 4. Left: Computation (Code_Saturne) of turbulent channel flow at 3 Reynolds numbers. Comparison with reference DNS of the results given by the EB-RSM integrated down to the wall (ItW, fine mesh) and the EB-RSM with analytical adaptive wall function (AAWF, 3 meshes). Right: EB-RSM computation (STARCCM+ code) of the wing-tip vortex generated by the flow around a NACA 0012 at 10 deg incidence. Visualisation of the streamlines colored with the streamwise vorticity.

In collaboration with industrial partners (EDF and CD-Adapco) developing CFD codes (code_Saturne and STARCCM+, respectively), we are working on the flexibility and robustness of the EB-RSM, an advanced Reynolds-stress turbulence model. Indeed, the two main problems that slow down the spreading of the use of such low-Reynolds number models (i.e., integrating the equations down to solid boundaries) in the industry are the impossibility to control the near-wall mesh quality in the whole domain of a complex industrial application and the occurrence of numerical instabilities due to spurious relaminarizations in some configurations.

In order to address the first issue, we are working, in particular in the frame of the PhD thesis of J.-F. Wald, on the development of adaptive wall functions, i.e., non-homogeneous Dirichlet boundary conditions for the turbulent variables dependant on the size of the cell adjacent to the wall. These wall functions are based on the physical properties of turbulence in the different layers of the near-wall region (asymptotic behaviour in the viscous sublayer and log law in the equilibrium layer), such a way that the flow is correctly reproduced whatever the near-wall refinement of the mesh. Fig. 4 (left) shows that the reproduction of the mean velocity profile in turbulent channel flows obtained using a typical, industrial mesh ($y^+ = 50$) remains very close to the grid-converged solution.

The second issue, the numerical instabilities due to local, spurious relaminarization of the model, can be addressed by investigating the solutions of the dynamical system formed by the model equations in homogeneous situations. Equilibrium solution are intersections of the nullclines (the locus of steady solutions for individual equations) and the stability properties of these fixed points can be visualized using trajectories in the phase space. By investigating the dependance of these stability properties on the parameters of the model, it is possible to eliminate undesired stable fixed points and thus to avoid the appearance of spurious

laminarization. Fig. 4 (right) shows the fully turbulent solution obtained with the modified model in a case where the original model exhibited a severe, unphysical relaminarization of the wing-tip vortex.

6.4. Assessment of the discontinuous Galerkin methods on curved meshes

The internship of Hamza Belkhayat-Zougari was concerned with the handling of high order curved meshes in the Aerosol library. During his internship, we developed new analytical solutions of the Laplace and of the Navier-Stokes equations on curved domains for emphasizing the limitation at second order of high order methods on straight meshes, and for assessing the right order on high order meshes. Example of order obtained on straight and curved meshes can be found on Figure 5 .

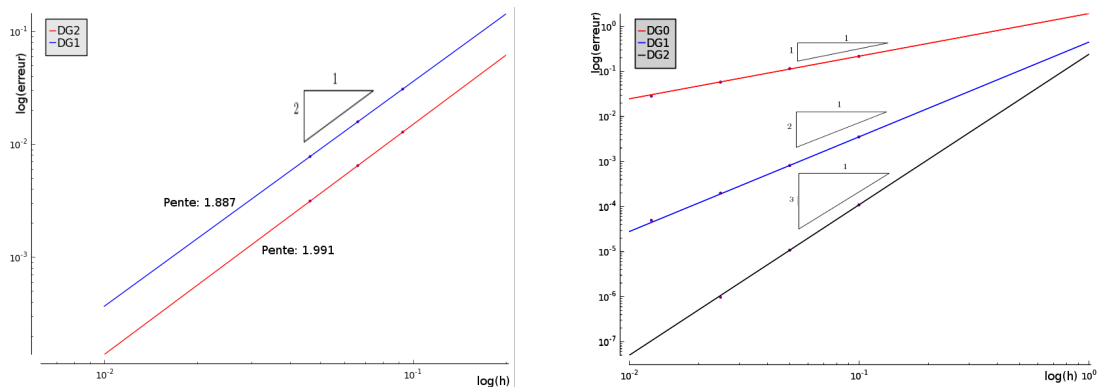

Figure 5. Convergence on a ring for the Laplace equation. Left: high order method on a straight mesh is limited to two. Right: third order accuracy can be recovered by using a second order mesh.

DEFI Project-Team

6. New Results

6.1. Qualitative methods for inverse scattering problems

6.1.1. *Identifying defects in an unknown background using differential measurements*

Participants: Lorenzo Audibert, Housseem Haddar.

With Alexandre Girard, we developed a new qualitative imaging method capable of selecting defects in complex and unknown background from differential measurements of farfield operators: i.e. far measurements of scattered waves in the cases with and without defects. Indeed, the main difficulty is that the background physical properties are unknown. Our approach is based on a new exact characterization of a scatterer domain in terms of the far field operator range and the link with solutions to so-called interior transmission problems. We present the theoretical foundations of the method and some validating numerical experiments in a two dimensional setting [10]. This work is based on the generalized formulation of the Linear Sampling Method with exact characterization of targets in terms of farfield measurements that has been introduced in [1].

6.1.2. *The Factorization Method for a Cavity in an Inhomogeneous Medium*

Participants: Housseem Haddar, Shixu Meng.

With F. Cakoni we considered the inverse scattering problem for a cavity that is bounded by a penetrable anisotropic inhomogeneous medium of compact support where one is interested in determining the shape of the cavity from internal measurements on a curve or surface inside the cavity. We derived a factorization method which provides a rigorous characterization of the support of the cavity in terms of the range of an operator which is computable from the measured data. The support of the cavity is determined without a-priori knowledge of the constitutive parameters of the surrounding anisotropic medium provided they satisfy appropriate physical as well as mathematical assumptions imposed by our analysis. Numerical examples were given showing the viability of our method [7].

6.1.3. *Asymptotic analysis of the transmission eigenvalue problem for a Dirichlet obstacle coated by a thin layer of non-absorbing media*

Participant: Housseem Haddar.

With F. Cakoni and N. Chaulet we considered the transmission eigenvalue problem for an impenetrable obstacle with Dirichlet boundary condition surrounded by a thin layer of non-absorbing inhomogeneous material. We derived a rigorous asymptotic expansion for the first transmission eigenvalue with respect to the thickness of the thin layer. Our convergence analysis is based on a Max–Min principle and an iterative approach which involves estimates on the corresponding eigenfunctions. We provided explicit expressions for the terms in the asymptotic expansion up to order 3 [3].

6.1.4. *Boundary Integral Equations for the Transmission Eigenvalue Problem for Maxwell's Equations*

Participants: Housseem Haddar, Shixu Meng.

In this work, we considered the transmission eigenvalue problem for Maxwell's equations corresponding to non-magnetic inhomogeneities with contrast in electric permittivity that changes sign inside its support. Following the approach developed by Cossonnière-Haddar in the scalar case, we formulate the transmission eigenvalue problem as an equivalent homogeneous system of boundary integral equation and prove that assuming that the contrast is constant near the boundary of the support of the inhomogeneity, the operator associated with this system is Fredholm of index zero and depends analytically on the wave number. Then we show the existence of wave numbers that are not transmission eigenvalues which by an application of the analytic Fredholm theory implies that the set of transmission eigenvalues is discrete with positive infinity as the only accumulation point. This is a joint work with F. Cakoni.

6.1.5. Invisibility in scattering theory

Participant: Lucas Chesnel.

We investigated a time harmonic acoustic scattering problem by a penetrable inclusion with compact support embedded in the free space. We considered cases where an observer can produce incident plane waves and measure the far field pattern of the resulting scattered field only in a finite set of directions. In this context, we say that a wavenumber is a non-scattering wavenumber if the associated relative scattering matrix has a non trivial kernel. Under certain assumptions on the physical coefficients of the inclusion, we showed that the non-scattering wavenumbers form a (possibly empty) discrete set. This result is important in the justification of certain reconstruction techniques like the Linear Sampling Method in practical applications.

In a second step, for a given real wavenumber and a given domain D , we developed a constructive technique to prove that there exist inclusions supported in D for which the corresponding relative scattering matrix is null. These inclusions have the important property to be impossible to detect from far field measurements. The approach leads to a numerical algorithm which allows to provide examples of (approximated) invisible inclusions. This is a joint work with A.-S. Bonnet-Ben Dhia and S.A. Nazarov [11].

6.1.6. Invisibility in electrical impedance tomography

Participant: Lucas Chesnel.

We adapted the technique to construct invisible isotropic conductivities in for the point electrode model in electrical impedance tomography. Again, the theoretical approach, based on solving a fixed point problem, is constructive and allows the implementation of an algorithm for approximating the invisible perturbations. We demonstrated the functionality of the method via numerical examples. This a joint work with N. Hyvönen and S. Staboulis [13].

6.1.7. A quasi-backscattering problem for inverse acoustic scattering in the Born regime

Participants: Housseem Haddar, Jacob Rezac.

In this work we propose a data collection geometry in which to frame the inverse scattering problem of locating unknown obstacles from far-field measurements of time-harmonic scattering data. The measurement geometry, which we call the quasi-backscattering set-up, is configured such that one device acts as a transmitter and a line of receivers extends in one-dimension a small distance from the transmitter. We demonstrate that the data collected can be used to locate inhomogeneities whose physical properties are such that the Born approximation applies. In particular, we are able to image a two-dimensional projection of the location of an obstacle by checking if a test function which corresponds to a point in \mathbb{R}^2 belongs to the range of a measurable operator. The reconstruction algorithm is based on the MUSIC (Multiple Signal Classification) algorithm.

6.2. Iterative Methods for Non-linear Inverse Problems

6.2.1. Inverse medium problem for axisymmetric eddy current models

Participants: Housseem Haddar, Zixian Jiang, Mohamed Kamel Riahi.

We continued our developments of shape optimization methods for inclusion detection in an axisymmetric eddy current model. This problem is motivated by non-destructive testing methodologies for steam generators. We finalized a joint work with A. Lechleiter on numerical methods for the solution of the direct problem in weighted Sobolev spaces using appropriate Dirichlet-to-Neumann mappings to bound the computational domain. We are also finalized jointly with M. El Guedri the work on inverse solver using a regularized steepest descent method for the problem of identifying a magnetite deposits using axial eddy current probe. We addressed two issues:

- We developed asymptotic models to identify thin highly conducting deposits. We derived three possible asymptotic models that can be exploited in the inverse problem. We are about to finalize a preprint on this topic.
- We extended the inverse scheme to 3D configurations with axisymmetry at infinity: this includes exact characterization of the shape derivative for a mixed formulation of eddy current problems and a parametric inversion scheme based on a pre-defined discrete grid for deposit location [14].

6.2.2. *The conformal mapping method and free boundary problems*

Participant: Housseem Haddar.

Together with R. Kress we employed a conformal mapping technique for the inverse problem to reconstruct a perfectly conducting inclusion in a homogeneous background medium from Cauchy data for electrostatic imaging, that is, for solving an inverse boundary value problem for the Laplace equation. In a recent work we proposed an extension of this approach to inverse obstacle scattering for time-harmonic waves, that is, to the solution of an inverse boundary value problem for the Helmholtz equation. The main idea is to use the conformal mapping algorithm in an iterative procedure to obtain Cauchy data for a Laplace problem from the given Cauchy data for the Helmholtz problem. We presented the foundations of the method together with a convergence result and exhibit the feasibility of the method via numerical examples. We are currently investigating the extension of this method to solve free boundary value problems.

6.2.3. *A steepest descent method for inverse electromagnetic scattering problems*

Participant: Housseem Haddar.

Together with N. Chaulet, we proposed the application of a non linear optimization techniques to solve the inverse scattering problems for the 3D Maxwell's equations with generalized impedance boundary conditions. We characterized the shape derivative in the case where the GIBC is defined by a second order surface operator. We then applied a boundary variation method based on a regularized steepest descent to solve the 3-D inverse problem with partial farfield data. The obtained numerical results demonstrated the possibility of identifying the shape of coated objects as well as the parameters of the coating in the 3D Maxwell case [4].

6.2.4. *A posteriori error estimates: Application to Electrical Impedance Tomography*

Participants: Olivier Pantz, Matteo Giacomini.

One of the main problem in shape optimization problems is due to the fact that the gradient is never computed exactly. When the current solution is far from a local optimum, this is not a problem: even a rough approximation of the gradient enable us to exhibit a descent direction. On the contrary, when close to a local optimal, a very precise computation of the gradient is needed. Together with Karim Trabelsi, we propose to use a-posteriori error estimates to evaluate the error made on the computation of the gradient. This enables us to ensure that at each step, a genuine descent direction is used in the gradient method. Our method has been applied to the minimization of the Kohn-Vogelius functional in the context of electrical impedance tomography. An article is currently in preparation.

6.2.5. *A robust stopping rule for EM algorithm with applications to SAXS measurements*

Participants: Federico Benvenuto, Housseem Haddar.

The aim of this work was to develop a fully automatic method for the reconstruction of the volume distribution of diluted polydisperse non-interacting nanoparticles with identical shape from Small Angle X-ray Scattering measurements. The described method solves a maximum likelihood problem with a positivity constraint on the solution by means of an Expectation Maximization iterative scheme coupled with an innovative type of regularization. Such a regularization, together with the positivity constraint results in high fidelity quantitative reconstructions of particle volume distributions making the method particularly effective in real applications. The performance of the method on synthetic data in the case of uni- and bi-modal particle volume distributions are shown. Moreover, the reliability of the method is tested when applied to real data provided by a Xenocs device prototype. Finally, the method can be extended to the analysis of the particle distribution for different types of nano-structures.

6.3. Shape and topology optimization

6.3.1. *Stacking sequence and shape optimization of laminated composite plates*

Participant: Grégoire Allaire.

We consider the optimal design of composite laminates by allowing a variable stacking sequence and in-plane shape of each ply. In order to optimize both variables we rely on a decomposition technique which aggregates the constraints into one unique constraint margin function. Thanks to this approach, a rigorous equivalent bi-level optimization problem is established. This problem is made up of an inner level represented by the combinatorial optimization of the stacking sequence and an outer level represented by the topology and geometry optimization of each ply. We propose for the stacking sequence optimization an outer approximation method which iteratively solves a set of mixed integer linear problems associated to the evaluation of the constraint margin function. For the topology optimization of each ply, we lean on the level set method for the description of the interfaces and the Hadamard method for boundary variations by means of the computation of the shape gradient. An aeronautic test case is exhibited subject to different constraints, namely compliance, reserve factor and first buckling load. This is joint work with G. Delgado.

6.3.2. Thickness control in structural optimization via a level set method

Participant: Grégoire Allaire.

In the context of structural optimization via a level-set method we propose a framework to handle geometric constraints related to a notion of local thickness. The local thickness is calculated using the signed distance function to the shape. We formulate global constraints using integral functionals and compute their shape derivatives. We discuss different strategies and possible approximations to handle the geometric constraints. We implement our approach in two and three space dimensions for a model of linearized elasticity. As can be expected, the resulting optimized shapes are strongly dependent on the initial guesses and on the specific treatment of the constraints since, in particular, some topological changes may be prevented by those constraints. This is a joint work with G. Michailidis

6.4. Asymptotic Analysis

6.4.1. Effective boundary conditions for thin periodic coatings

Participants: Mathieu Chamaillard, Houssein Haddar.

This topic is the object of a collaboration with Patrick Joly and is a continuation of our earlier work on interface conditions done in the framework of the PhD thesis of Berangère Delourme. The goal here is to derive effective conditions that model scattering from thin periodic coatings where the thickness and the periodicity are of the same length but very small compared to the wavelength. The originality of our work, compared to abundant literature is to consider the case of arbitrary geometry (2-D or 3-D) and to consider higher order approximate models. We formally derived third order effective conditions after exhibiting the full asymptotic expansion of the solution in terms of the periodicity length.

6.4.2. Homogenization of the transmission eigenvalue problem with applications to inverse problems

Participant: Houssein Haddar.

In a joint work with F. Cakoni and I. Harris, we consider the interior transmission problem associated with the scattering by an inhomogeneous (possibly anisotropic) highly oscillating periodic media. We show that, under appropriate assumptions, the solution of the interior transmission problem converges to the solution of a homogenized problem as the period goes to zero. Furthermore, we prove that the associated real transmission eigenvalues converge to transmission eigenvalues of the homogenized problem. Finally we show how to use the first transmission eigenvalue of the period media, which is measurable from the scattering data, to obtain information about constant effective material properties of the periodic media. The obtained convergence results are not optimal. Such results with rate of convergence involve the analysis of the boundary correction and will be subject of a forthcoming paper.

6.4.3. Homogenization of electrokinetic models in porous media

Participant: Grégoire Allaire.

With R. Brizzi, J.-F. Duf r che, A. Mikelic and A. Piatnitski, are interested in the homogenization (or upscaling) of a system of partial differential equations describing the non-ideal transport of a N-component electrolyte in a dilute Newtonian solvent through a rigid porous medium. Our recent work has focused on the so-called non-ideal case. Namely we consider the mean spherical approximation (MSA) model which takes into account finite size ions and screening effects. On the one hand we established a rigorous homogenized transport model starting from this microscopic model. On the other hand we did numerical simulations to compute the corresponding effective parameters and make systematic comparisons between the idea model and the MSA model.

6.4.4. Modeling and Simulation of the Mechanical behavior of Vesicles and Red Blood Cells

Participant: Olivier Pantz.

6.4.4.1. Highly anisotropic thin shells

With K. Trabelsi (IPSA), we have proposed a new justification of various non linear highly anisotropic elastic shell models. Among others, we do derive the so called Helfrich functional, that describe the behavior of the lipid bilayer of the vesicle and red blood cells. Our results will soon be published in MEMOCS (Mathematics and Mechanics Complex Systems).

6.4.4.2. Minimization of the Helfrich functional

Our work with K. Trabelsi established that the mechanical behavior of vesicles and red blood cells can be approximated by thin non linear anisotropic elastic shells. Minimizing directly the Helfrich functional is not an easy task from the numerical point of view. Most methods require the use of high order finite elements and stabilization techniques so to prevent mesh degeneration. Instead, we propose to approximate the two dimensional membrane of a vesicle (or red blood cell) by a three dimensional non linear elastic body of small thickness. Firstly, this enable us to use standard finite elements and discretization (basically Lagrange of degree 2). Secondly, the discretized formulation is intrinsically stable, so no stabilization is needed. Finally, even if it leads us to solve a three dimensional problem (instead of the two dimensional initial one), it is no more costly than a direct two dimensional approach as the scale of the mesh can be chosen to be of the same order than the "thickness" of the shell. We have already obtained encouraging results for vesicles. We plan to extend them to the case of vesicles with spontaneous curvature and to red blood cells. Moreover, we are considering different strategies to minimize the computational cost (that is already quite satisfying compared with some other methods).

6.4.5. Modeling of Damage and Fracture

Participant: Olivier Pantz.

6.4.5.1. Fracture as limit of Damage

With Leila Azem (PhD Student), we use a model introduced by G. Allaire, F. Jouve and N. Van Goethem in a previous work to simulate the propagation of fracture. The main idea is to approximate the fracture as a damage material and to compute the evolution of the path of the crack using a shape gradient analysis. Our main contribution consists to propose to use a material derivative approach to compute the shape gradient. The advantage is that it drastically simplify the evaluation of the shape gradient, as no regularization is needed and no jump terms as to be computed on the interface bewteen the healthy and damaged areras. An article is currently in preparation to present our results.

6.4.5.2. Fracture with penalization of the jump

With Leila Azem, we propose to approximate a model of fracture with penalization of the jump of the displacement as a limit of a damage model. This is achieved by a specific choice of the softness of the damage material with respect to the cost to turn material from a healthy to a damaged state. We have carried out a formal analysis to justify our approach and have already obtained several numerical results.

6.5. Diffusion MRI

Participants: Jing-Rebecca Li, Housseem Haddar, Simona Schiavi, Khieu Van Nguyen, Gabrielle Fournet, Dang Van Nguyen.

Diffusion Magnetic Resonance Imaging (DMRI) is a promising tool to obtain useful information on microscopic structure and has been extensively applied to biological tissues. In particular, we would like to focus on two applications:

- Inferring from DMRI measurements changes in the cellular volume fraction occurring upon various physiological or pathological conditions. This application is one of the first to show the promise of DMRI because it can detect acute cerebral ischemia (cell swelling) on the basis of lower than normal apparent diffusion coefficient a few minutes after stroke;
- Estimating the average cell size in the case of tumor imaging This application is useful as a diagnostic tool as well as a tool for the evaluation of tumor treatments;

For both of the above applications we approach the problem via the following steps:

- Construct reduced models of the multiple-compartment Bloch-Torrey partial differential equation (PDE) using homogenization methods.
- Invert the resulting reduced models for the biological parameters of interest: the cellular volume fraction in the first case, and the average distance between neighboring cells in the second case.

We obtained the following results.

- We derived using homogenization techniques an asymptotic model of the diffusion MRI signal for finite pulse magnetic field gradient sequences in the long diffusion time regime and numerically verified it using a Finite Element method for both isotropic and anisotropic diffusion configurations in three dimensions. This resulted in 2 publications.
- We derived a new asymptotic model of the diffusion MRI signal for low gradient strengths that is valid for a wide range of diffusion time scales. An article describing our results is under preparation.
- We performed a numerical study of a cylinder model of the diffusion MRI signal for neuronal dendrite trees. This resulted in 1 publication.
- We implemented a compressed sensing method for obtaining T2-weighted images in shorter scanning time and this method was used to segment nerve cells of the *Aplysia Californica* at the MRI center Neurospin. An article describing our results is under preparation.
- We participated in the characterization of glioma microcirculation and tissue features in a rat brain model using diffusion-encoding magnetic field gradient pulses sequences, working along with collaborators at the high field brain MRI center Neurospin. This resulted in 1 publication.
- We performed Monte-Carlo simulation of blood flow in micro-vessels in the brain with the goal of using the results to explain the MRI signal drop due to incoherent flow in the micro-vessels. This is an ongoing project.

ECUADOR Project-Team

6. New Results

6.1. Resolution of linearised systems

Participants: Olivier Allain [Lemma], Gautier Brèthes, Alain Dervieux, Bruno Koobus, Stephen Wornom.

For Fluid Mechanics as well as for Structural Mechanics, implicit time-advancing is mandatory. It can be applied efficiently if the large systems involved are solved with a good parallel algorithm. In the 90's, a generation of solution algorithms was devised on the basis of Domain Decomposition Methods (DDM). For complex models such as compressible flows, Schwarz DDM were combined with quasi-Newton algorithms like GMRES. For example in the Aironum tool, we use Restrictive Additive Schwarz (RAS, developed by Cai and Farhat). RAS is an ancestor of the widely used class of Newton-Krylov-Schwarz (NKS) algorithms. NKS are, in some versions including RAS, almost scalable *i.e.* their convergence rate is independant of the number of processors. But scalability degrades over a thousand processors. During the ANR ECINADS, coordinated by Ecuador, a Coarse-Grid Deflated RAS was developed. The algorithmic scalability (iteration-wise) holds for all part, except for the coarse grid direct solver, which concerns a much smaller problem. Effective Convergence Scalability (ECS) was confirmed up to 2048 processors. After this level, the asymptotic complexity of the coarse-grid direct solver become predominant and ECS is lost. In other words, with a Coarse-Grid Deflated RAS, the size of the coarse grid problem must be limited in order to enjoy ECS.

In the thesis of Gautier Brèthes, we now study a further step towards super-massive scalability: we use a number of fine and medium grids in order to solve the target large system by a multi-mesh multigrid (MG) algorithm. An important novelty is that the complete FMG technology is applied, with a new stopping criterion avoiding useless cycling [12]. It is well-known that parallel MG is limited to “no-too-coarse” coarse levels due to an excessive ratio between communication and computation. Now our parallel MG can be complemented by the previous version of the solver (deflated RAS) for this no-too-coarse coarse level.

6.2. Algorithmic Differentiation of a CFD code

Participants: Valérie Pascual, Laurent Hascoët, Alain Dervieux.

This activity continues in collaboration with the partners of the FP7 project UMRIDA. The team is assisting Alenia-Aermacchi in the efficient differentiation of its Euler/Navier Stokes UNS3D code in tangent mode, using in particular a differentiable extension of the MPI library.

Inside a collaboration with EDF, Valérie Pascual is also applying Tapenade to produce various adjoint differentiations of the hydrographic code Mascaret.

6.3. Control of approximation errors

Participants: Gautier Brèthes, Eléonore Gauci, Alain Dervieux, Adrien Loseille [Gamma team, Inria-Rocquencourt], Frederic Alauzet [Gamma team, Inria-Rocquencourt], Stephen Wornom, Olivier Allain [Lemma], Anca Belme [University Paris VI].

A study of an interesting combination of Full Multigrid (FMG) and Anisotropic mesh Adaptation (AA) started last year, with the beginning of the thesis of Gautier Brèthes. FMG is one of the (very) few algorithm giving N results by consuming kN floats. Anisotropic adaptation produces approximation errors less than ε with $N = \varepsilon^{-\frac{1}{d_{im}}}$ nodes, this for smooth and non-smooth solution fields. Anisotropic adaptative FMG may produce approximation errors less than ε by consuming $k\varepsilon^{-\frac{1}{d_{im}}}$ floats. Moreover, theory and experiments show that FMG works better when combined with AA. A first AA-FMG platform has been developed. It combines several mesh-adaptation modules developed by Gamma and Distene. It is used for testing new adaptation criteria.

Third-order mesh adaptation was the main topic of last year in error control. The scheme is the ENO finite-volume formulation with quadratic reconstruction. An article describing our results for 2D applications is being written. A 3D version is developed in the Aironum CFD platform. A cooperation with Lemma is also running, with Eléonore Gauci, to apply the scheme to fluid-gas interfaces. Further studies of mesh adaptation for viscous flows are ongoing and an article in collaboration with Gamma3 and University Paris VI (Anca Belme) is being written.

An important novelty in mesh adaptation is the norm-oriented AA method. The method relies on the definition of ad hoc correctors. It has been developed in the academic FMG platform for elliptic problems. Another version is developed by Gamma, in collaboration with Ecuador, for the compressible flow models. The purpose is to devise a composite algorithm in which an approximation error norm can be specified by the user. The introduction of the norm-oriented idea considerably amplifies the impact of adjoint-based AA. The applied mathematician and the engineer now have methods when faced to mesh adaptation for the simulation of a complex PDE system, since they can specify which error norm level they wish, and for which norm. Eléonore Gauci starts a thesis, co-advised by Alain Dervieux and Frédéric Alauzet, on the norm-oriented criteria for CFD and coupled CSM-CFD systems. She also works on a new version of the mesh adaptive CFD demonstrator of Gamma3. This new version improves the resolution of curved features. A cooperation is also starting between Gautier Brèthes and Thierry Coupez (Ecole Centrale de Nantes) on discrete metrics.

These studies are supported by an European FP7 project UMRIDA which deals with the application of AA to approximation error modelling and control, and by ANR project MAIDESC coordinated by Ecuador, which deals with meshes for interfaces, third-order accuracy, meshes for boundary layers, and curved meshes.

6.4. Turbulence models

Participants: Emmanuelle Itam [University Montpellier II], Alain Dervieux, Bruno Koobus, Carine Mousaëd [University Montpellier II], Maria-Vittoria Salvetti [University of Pisa], Stephen Wornom, Bruno Sainte-Rose [Lemma].

The purpose of our work in hybrid RANS/LES is to develop new approaches for industrial applications of LES-based analyses. This year, many experiments have validated the dynamic version of our VMS-LES. The quality of simulations is either comparable to non-dynamic, or better. In the applications targetted (aeronautics, hydraulics), the Reynolds number can be as high as several tenth millions, far too high for pure LES models. However, certain regions in the flow can be better predicted with LES than with usual statistical RANS (Reynolds averaged Navier-Stokes) models. These are mainly vortical separated regions as assumed in one of the most popular hybrid model, the hybrid Detached Eddy Simulation model. Here, “hybrid” means that a blending is applied between LES and RANS. An important difference between a real life flow and a wind tunnel or basin is that the turbulence of the flow upstream of each body is not well known. This year, we have started the study of multiple-body flows. A typical case is the interaction between two parallel cylinders, one being in the wake of the other. A recent workshop showed the rather disastrous predictions of LES models. Most hybrid models behave better, mainly for the first cylinder. We are progressively extending and validating our VMS-LES model and our hybrid ones ([11]).

6.5. AD tools infrastructure

Participants: Laurent Hascoët, Paul Hovland [Argonne National Lab. (Illinois, USA)], Sri Hari Krishna Narayanan [Argonne National Lab. (Illinois, USA)].

We have an ongoing partnership with Paul Hovland’s team at Argonne National Lab, formalized by joint participation in the Inria-Illinois joint lab on petascale computing and with travels funded by the Partner University Fund (PUF) of the French embassy in the USA.

In this framework, we worked on the goal of blending our AD tool Tapenade with Argonne's tool OpenAD, by developing bridges between their internal representations, through a common external representation of analyzed programs. This representation called XAIF is based on XML. We have developed running prototypes of these bridges in both directions, that run on a few examples and that need further development to allow each tool to take advantage of the other's analyses and models. This was supported by two visits of Krishna Narayanan to Inria and one of Laurent Hascoët to Argonne.

We also continued joint development of the Adjoinable-MPI library (AMPI) that provides efficient tangent and adjoint differentiation for MPI-parallel codes, independently of the AD tool used (now AdolC, dco, OpenAD, Tapenade).

We also extracted from Tapenade a standalone kernel (with documented API) for program parsing, analysis, and unparsing, which is not specific to AD and which could be used to develop other source-to-source code transformations. Paul Hovland's team and another Argonne team have shown interest for this library.

6.6. Algorithmic Differentiation and Dynamic Memory

Participants: Laurent Hascoët, Sri Hari Krishna Narayanan [Argonne National Lab. (Illinois, USA)].

In the same framework as in section 6.5, we made progress in the development of the adjoint AD model for programs that use dynamic memory. Adjoint differentiated code obtained by source transformation (OpenAD, Tapenade...) consists of a forward sweep that essentially copies the original code, and a backward sweep that computes the derivatives. These two sweeps must have the same control-flow shape, only reversed. The allocation and deallocation of dynamic memory inside the forward sweep requires a similar pattern in the backward sweep. However, allocations do not always return the same memory chunk, and therefore all memory addresses must be updated to preserve their consistency in the backward sweep.

This problem can only be solved at run-time. A compile-time analysis simply cannot extract the information needed. Our approach is thus to design a library that encapsulates all calls to memory allocation primitives (`malloc`, `free`...) in order to register the allocated addresses and to restore consistency of pointers during the backward sweep. This strategy is similar to the one we use for MPI calls, cf 6.5, and is actually an ingredient in our AMPI strategy.

This approach was tested with success on a medium-size industrial application in structural mechanics. For this unsteady simulation the C code allocates and frees memory repeatedly at each time step. The tangent and adjoint differentiated C codes, as produced by Tapenade, have been adapted by hand to run the new model, showing promising performance. Obviously, the next step is to update the Tapenade AD model to automate this hand adaptation.

6.7. Algorithmic Differentiation and Iterative Processes

Participants: Laurent Hascoët, Ala Taftaf.

Adjoint codes naturally propagate partial gradients backwards from the result of the simulation. However, this uses the data flow of the simulation in reverse order, at a cost that increases with the length of the simulation. In the special case of iterative Fixed-Point loops, it is clear that the first iterations operate on a meaningless "initial guess" state vector, and that reversing the corresponding data-flow is wasted effort. An adapted adjoint strategy for the iterative process should consider only the last or the few last iterations. Also the adjoint loop, which is itself a Fixed-Point iteration, must have its own stopping criterion and not merely run as many times as the direct Fixed-Point loop. We selected the strategy proposed by Bruce Christianson [17] and this year we implemented it in Tapenade. This strategy is triggered by differentiation directives that we defined. We tested this strategy with success on the medium-size testcase provided by Queen Mary University for the AboutFlow project.

Ala Taftaf presented her results at the WCCM congress during the Ecomas conference in Barcelona [13], July 21-25. Ala Taftaf did a two-months secondment for her Marie Curie PhD grant, with our partner team of Queen Mary University of London, during which she helped them take advantage of the latest developments in Tapenade and of her developments about Fixed-Point adjoints.

6.8. Multi-Activity specialized Differentiation

Participants: Laurent Hascoët, Ian Hueckelheim [Queen Mary University of London].

Up to this year, Tapenade did not allow for specialization of differentiated routines for different “activity” patterns. If a procedure must be differentiated once with respect to some of its arguments, and once with respect to another subset of arguments, then only one generalized differentiated procedure is created, with respect to the union of all subsets of active arguments. This incurs an efficiency penalty, but avoids a combinatorial explosion of the differentiated code.

However, there are cases where the efficiency penalty is high, and some users want more flexibility. Also the specialized adjoint for Fixed-Point iterations *cf* 6.7 uses two distinct activity patterns for the Fixed-Point loop body, and merging them loses some of the benefits of the approach. We have modified Tapenade to perform activity-specialized differentiation, giving the end-user a complete control through differentiation directives.

The experiments on a non-contrived industrial testcase of the AboutFlow project showed a non-negligible improvement between 5 to 10%. Work is still in progress to incorporate this new functionality into the mainstream distributed Tapenade. Ian Hueckelheim presented these results at the 16th EuroAD workshop in Jena, Germany, December 8-9.

GAMMA3 Project-Team

4. New Results

4.1. Serendipity and reduced elements

Participants: Paul Louis George [correspondant], Houman Borouchaki, Nicolas Barral.

We give a method to constructing Serendipity elements for quads and hexes with full symmetry properties and indicate the reading of their shape functions. We show that, since the degree 5, the Serendipity elements are no longer symmetric but we propose a method resulting in a Lagrange element of degree 5 with full symmetry properties after adding an adequate number of additional nodes.

On the other hand, we show how to guarantee the geometric validity of a given curved element (seen as a patch) of a mesh. This is achieved after writing the patch in a Bézier setting (Bernstein polynomials and control points). In addition, we discuss the case of patch derived from a transfinite interpolation and it is proved that only some of them are Serendipity elements indeed, we return to the same elements as above

We also give a method to constructing Lagrange Serendipity (or reduced) simplices with a detailed description of the triangles of degree 3 and 4. We indicate that higher order triangles are not candidate apart if we impose a restricted polynomial space. We show that a tetrahedron of degree 3 is a candidate while high order elements are not candidate even if a restriction in the polynomial space is considered. In addition, we propose a method for the validation of such elements, in a given mesh, where the validation means the positiveness of the jacobian.

A technical report have been published [29].

4.2. Validity of transfinite and Bézier-Serendipity patches

Participants: Paul Louis George [correspondant], Houman Borouchaki, Nicolas Barral.

We define generalized transfinite patches for quads and hexes with full symmetry properties. We give a way of constructing those patches by considering the Bézier setting using linear combinations of tensor-product patches of various degree. Those patches are exactly the Bézier-Serendipity patches recently introduced

ASfor reduced quadrilateral patches, we introduce the so called "Bézier-Serendip" patches. After some recalls about standard Bézier patches, we propose a method to constructing those reduced patches. The corresponding Bernstein polynomials are written by means of linear combinations of the standard Bernstein polynomials. We give a full description of the patches of degree 2, 3, 4 and 5. Since degree 5, the location of the control points is no longer symmetric and to remedy this problem, we propose adding a number of control points which results in *extended* Bézier-Serendip patches. Those reduced patches are in the Bézier framework what the Serendipity elements are in the finite element framework.

A technical report and a paper have been published [30], [17].

4.3. Meshing Strategies and the Impact of Finite Element Quality on the Velocity Field in Fractured Media

Participants: Patrick Laug [correspondant], Géraldine Pichot.

For calculating flow in a fracture network, the mixed hybrid finite element (MHFE) method is a method of choice as it yields a symmetric, positive definite linear system. However, a drawback to this method is its sensitivity to bad aspect ratio elements. For poor-quality triangles, elementary matrices are ill-conditioned, and inconsistent velocity vectors are obtained by inverting these local matrices. In this work, different strategies have been proposed for better reconstruction of the velocity field [21].

4.4. Automatic Mesh Generation of Multiface Models on Multicore Processors

Participant: Patrick Laug [correspondant].

This work started in September 2014, as part of a sabbatical at Polytechnique Montréal. In a previous study, a parallel version of an indirect approach for meshing composite surfaces – also called multiface models – was developed. However, this methodology could be inefficient in practice, as the memory management of most existing CAD (computer aided design) systems use static global caches to save information. In our new approach, CAD queries are fully parallelized, using the Pirate library from Polytechnique Montréal. This library provides a set of C++ classes that implement STEP-compliant B-Rep geometric and topological entities, as well as classes to represent meshes and solutions. By modifying the data structures so that memory caches are local to each face of the geometric model, geometric primitives can efficiently be evaluated in parallel, and performance measurements show significant gains.

4.5. Applications du maillage et développements de méthodes avancées pour la cryptographie

Participants: Thomas Grosgees [correspondant], Dominique Barchiesi, Michael François.

L'utilisation des nombres (pseudo)-aléatoires a pris une dimension importante ces dernières décennies. De nombreuses applications dans le domaine des télécommunications, de la cryptographie, des simulations numériques ou encore des jeux de hasard, ont contribué au développement et à l'usage de ces nombres. Les méthodes utilisées pour la génération de tels nombres (pseudo)-aléatoires proviennent de deux types de processus : physique et algorithmique. Ce projet de recherche a donc pour objectif principal le développement de nouveaux procédés de génération de clés de chiffrement, dits "exotiques", basés sur des processus physiques, multi-échelles, multi-domaines assurant un niveau élevé de sécurité. Deux classes de générateurs basés sur des principes de mesures physiques et des processus mathématiques ont été développés.

La première classe de générateurs exploite la réponse d'un système physique servant de source pour la génération des séquences aléatoires. Cette classe utilise aussi bien des résultats de simulation que des résultats de mesures interférométriques pour produire des séquences de nombres aléatoires. L'application du maillage adaptatif sert au contrôle de l'erreur sur la solution des champs physiques (simulés ou mesurés). A partir de ces cartes physiques, un maillage avec estimateur d'erreur sur l'entropie du système est appliqué. Celui-ci permet de redistribuer les positions spatiales des noeuds. L'étude (locale) de la réduction d'entropie des clés tout au long de la chaîne de création et l'étude (globale) de l'entropie de l'espace des clés générées sont réalisées à partir de tests statistiques.

La seconde classe de générateurs porte sur le développement de méthodes avancées et est basée sur l'exploitation de fonctions chaotiques en utilisant les sorties de ces fonctions comme indice de permutation sur un vecteur initial. Ce projet s'intéresse également aux systèmes de chiffrement pour la protection des données et deux algorithmes de chiffrement d'images utilisant des fonctions chaotiques sont développés et analysés. Ces Algorithmes utilisent un processus de permutation-substitution sur les bits de l'image originale. Une analyse statistique approfondie confirme la pertinence des cryptosystèmes développés.

4.6. Développement de méthodes avancées et maillages appliqués à l'étude de la nanomorphologie des nanotubes-fils en suspension liquide

Participants: Thomas Grosgees [correspondant], Dominique Barchiesi, Abel Cherouat, Houman Borouchaki, Laurence Giraud-Moreau, Anis Chaari.

Ce projet de recherche (NANOMORPH) a pour objet principal le développement et la mise au point d'une instrumentation optique pour déterminer la distribution en tailles et le coefficient de forme de nanofils (NF) ou de nanotubes (NT) en suspension dans un écoulement. Au cours de ce projet, deux types de techniques optiques complémentaires sont développées. La première, basée sur la diffusion statique de la lumière, nécessite d'étudier au préalable la physico-chimie de la dispersion, la stabilisation et l'orientation des nanofils dans les milieux d'étude. La seconde méthode, basée sur une méthode opto-photothermique pulsée, nécessite en sus, la modélisation de l'interaction laser/nanofils, ainsi que l'étude des phénomènes multiphysiques induits par ce processus. L'implication de l'équipe-projet GAMMA3 concerne principalement la simulation multiphysique de l'interaction laser-nanofils et l'évolution temporelle des bulles et leurs formations. L'une des principales difficultés de ces problématiques est que la géométrie du domaine est variable (à la fois au sens géométrique et topologique). Ces simulations ne peuvent donc être réalisées que dans un schéma adaptatif de calcul nécessitant le remaillage tridimensionnel mobile, déformable avec topologie variable du domaine (formation et évolution des bulles au cours du temps et de l'espace).

4.7. Applications du maillage à des problèmes multi-physiques, développement de méthodes de résolutions avancées et modélisation électromagnétique-thermique-mécanique à l'échelle mesoscopique

Participants: Dominique Barchiesi [correspondant], Abel Cherouat, Thomas Grosge, Houman Borouchaki, Laurence Giraud-Moreau, Sameh Kessentini, Anis Chaari, Fadhil Mezghani.

Le contrôle et l'adaptation du maillage lors de la résolution de problèmes couplés ou/et non linéaires reste un problème ouvert et fortement dépendant du type de couplage physique entre les EDP à résoudre. Notre objectif est de développer des modèles stables afin de calculer les dilatations induites par l'absorption d'énergie électromagnétique, par des structures matérielles inférieures au micron. Les structures étudiées sont en particulier des nanoparticules métalliques en condition de résonance plasmon. Dans ce cas, un maximum d'énergie absorbée est attendu, accompagné d'un maximum d'élévation de température et de dilatation. Il faut en particulier développer des modèles permettant de simuler le comportement multiphysique de particules de formes quelconques, pour une gamme de fréquences du laser d'éclairage assez étendue afin d'obtenir une étude spectroscopique de la température et de la dilatation. L'objectif intermédiaire est de pouvoir quantifier la dilatation en fonction de la puissance laser incidente. Le calcul doit donc être dimensionné et permettre finalement des applications dans les domaines des capteurs et de l'ingénierie biomédicale. En effet, ces nanoparticules métalliques sont utilisées à la fois pour le traitement des cancers superficiels par nécrose de tumeur sous éclairage adéquat, dans la fenêtre de transparence cellulaire. Déposées sur un substrat de verre, ces nanoparticules permettent de construire des capteurs utilisant la résonance plasmon pour être plus sensibles (voir projet européen *Nanoantenna* et l'activité génération de nombres aléatoires). Cependant, dans les deux cas, il est nécessaire, en environnement complexe de déterminer la température locale, voire la dilatation de ces nanoparticules, pouvant conduire à un désaccord du capteur, la résonance plasmon étant très sensible aux paramètres géométriques et matériels des nanostructures. Dans ce sens, l'étude permet d'aller plus loin que la "simple" interaction électromagnétique avec la matière du projet européen *Nanoantenna*.

Le travail de l'année 2014 a constitué en la poursuite de l'étude des spécificités de ce type de problème multiphysique pour des structures de forme simple et la mise en place de fonctions test, de référence, pour les développements de maillage adaptatifs pour les modèles multiphysiques éléments finis. Nous espérons pouvoir proposer un projet ANR couplant les points de vue microscopiques et macroscopiques dans les deux années qui viennent.

4.8. Visualization and modification of high-order curved meshes

Participants: Alexis Loyer, Adrien Loseille [correspondant].

During the partnership between Inria and Distene, a new visualization software has been designed. It address the typical operations that are required to quickly assess the newly algorithm developed in the team. In particular, interactive modifications of high-order curved mesh and hybrid meshes has been addressed. The software VIZIR is freely available at <https://www.rocq.inria.fr/gamma/gamma/vizir/>.

4.9. Mesh adaptive ALE numerical simulation

Participants: Frédéric Alauzet [correspondant], Nicolas Barral, Adrien Loseille.

Running highly accurate numerical simulations with moving geometries is still a challenge today due to their prohibitive cost in CPU time. Using anisotropic mesh adaptation is one way to drastically reduce the size of the problem and to reach the desired accuracy. Previously, we have developed an ALE formulation using mesh connectivity change in order to achieve any complex displacement. Then, this method has been coupled with the unsteady anisotropic mesh adaptation using the fixed-point algorithm. The key point of this work is the use of an ALE metric that takes into account the mesh motion in the metric field definition [24], [14].

4.10. Mesh adaptation for Navier-Stokes Equations

Participants: Frédéric Alauzet, Victorien Menier, Adrien Loseille [correspondant].

Adaptive simulations for Navier-Stokes equations require to propose accurate error estimates and design robust mesh adaptation algorithms (for boundary layers).

For error estimates, we design new estimates suited to accurately capture the speed profile in the boundary layers. For mesh adaptation, we design a new method to generate structured boundary layer meshes which are mandatory to accurately compute compressible flows a high Reynolds number (several millions). It couple the specification of the optimal boundary layer from the geometry boundary and moving mesh techniques to extrude the boundary layer in an already existing mesh. The main advantage of this approach is its robustness, *i.e.*, at each step of the algorithm we have always a valid mesh [25].

4.11. Adaptive multigrid strategies

Participants: Frédéric Alauzet [correspondant], Victorien Menier, Adrien Loseille.

Multigrid is a well known technique used to accelerate the convergence of linear system solutions. Using a multigrid strategy to solve non-linear problems improves the robustness and the convergence of each Newton step, the accelerating overall the whole process. In particular, larger time step can be considered. This of main importance when solving turbulent Navier-Stokes equations on complex geometries. First, we developed the classical multigrid method on non-nested meshes. Then, we have pointed out the similarity between the Full MultiGrid (FMG) algorithm and the mesh adaptation algorithm. We have proposed a new Adaptive Full MultiGrid algorithm which improve the overall robustness of the adaptive process and its overall efficiency [25].

4.12. Metric-orthogonal and metric-aligned mesh adaptation

Participants: Frédéric Alauzet, Victorien Menier, Adrien Loseille [correspondant].

A new algorithm to derive adaptive meshes has been introduced through new cavity-based algorithms. It allows to generate anisotropic surface and volume mesh that are aligned along the eigenvector directions. This allows us to improv the quality of the meshes and to deal naturally with boundary layer mesh generation [19], [27].

IPSO Project-Team

5. New Results

5.1. Highlights of the Year

- E. Faou was plenary speaker at the CANUM, Congrès d'analyse numérique, France, June 2014
- E. Faou was invited to give two presentations in the Analysis and applied mathematics seminars, Cambridge, UK, February 2014.

5.2. Multi-revolution composition methods for highly oscillatory differential equations

In [22], we introduce a new class of multi-revolution composition methods (MRCM) for the approximation of the N th-iterate of a given near-identity map. When applied to the numerical integration of highly oscillatory systems of differential equations, the technique benefits from the properties of standard composition methods: it is intrinsically geometric and well-suited for Hamiltonian or divergence-free equations for instance. We prove error estimates with error constants that are independent of the oscillatory frequency. Numerical experiments, in particular for the nonlinear Schrödinger equation, illustrate the theoretical results, as well as the efficiency and versatility of the methods.

5.3. Multiscale schemes for the BGK-Vlasov-Poisson system in the quasi-neutral and fluid limits. Stability analysis and first order schemes

In [51], in collaboration with G. Dimarco (University of Ferrara, Italy) and M.-H. Vignal (University of Toulouse), we deal with the development and the analysis of asymptotic stable and consistent schemes in the joint quasi-neutral and fluid limits for the collisional Vlasov-Poisson system. In these limits, the classical explicit schemes suffer from time step restrictions due to the small plasma period and Knudsen number. To solve this problem, we propose a new scheme stable for choices of time steps independent from the small scales dynamics and with comparable computational cost with respect to standard explicit schemes. In addition, this scheme reduces automatically to consistent discretizations of the underlying asymptotic systems. In this first work on this subject, we propose a first order in time scheme and we perform a relative linear stability analysis to deal with such problems. The framework we propose permits to extend this approach to high order schemes in the next future. We finally show the capability of the method in dealing with small scales through numerical experiments.

5.4. Asymptotic preserving scheme for a kinetic model describing incompressible fluids

In [52], in collaboration with M. Lemou (CNRS, Université de Rennes 1) and R. Rao, A. Ruhi, M. Sekhar (Indian Institute of Science, India), the kinetic theory of fluid turbulence modeling developed by Degond and Lemou is considered for further study, analysis and simulation. Starting with the Boltzmann like equation representation for turbulence modeling, a relaxation type collision term is introduced for isotropic turbulence. In order to describe some important turbulence phenomenology, the relaxation time incorporates a dependency on the turbulent microscopic energy and this makes difficult the construction of efficient numerical methods. To investigate this problem, we focus here on a multi-dimensional prototype model and first propose an appropriate change of frame that makes the numerical study simpler. Then, a numerical strategy to tackle the stiff relaxation source term is introduced in the spirit of Asymptotic Preserving Schemes. Numerical tests are performed in a one-dimensional framework on the basis of the developed strategy to confirm its efficiency.

5.5. Comparison of numerical solvers for anisotropic diffusion equations arising in plasma physics

In [39], in collaboration G. Latu (IRFM, Cadarache), we performed a comparison of numerical schemes to approximate anisotropic diffusion problems arising in tokamak plasma physics. We focus on the spatial approximation by using finite volume method and on the time discretization. This latter point is delicate since the use of explicit integrators leads to a severe restriction on the time step. Then, implicit and semi-implicit schemes are coupled to finite volumes space discretization and are compared for some classical problems relevant for magnetically confined plasmas. It appears that the semi-implicit approaches (using ARK methods or directional splitting) turn out to be the most efficient on the numerical results, especially when nonlinear problems are studied on refined meshes, using high order methods in space.

5.6. Asymptotic-Preserving scheme based on a Finite Volume/Particle-In-Cell coupling for Boltzmann- BGK-like equations in the diffusion scaling

In [38], in collaboration with A. Crestetto (University of Nantes), we are concerned with the numerical simulation of the collisional Vlasov equation in the diffusion limit using particles. To that purpose, we use a micro-macro decomposition technique introduced by Bennoune, Lemou and Mieussens. Whereas a uniform grid was used to approximate both the micro and the macro part of the full distribution function in their article, we use here a particle approximation for the kinetic (micro) part, the fluid (macro) part being always discretized by standard finite volume schemes. There are many advantages in doing so: (i) the so-obtained scheme presents a much less level of noise compared to the standard particle method; (ii) the computational cost of the micro-macro model is reduced in the diffusion limit since a small number of particles is needed for the micro part; (iii) the scheme is asymptotic preserving in the sense that it is consistent with the kinetic equation in the rarefied regime and it degenerates into a uniformly (with respect to the Knudsen number) consistent (and deterministic) approximation of the limiting equation in the diffusion regime.

5.7. Hamiltonian splitting for the Vlasov-Maxwell equations

In [23], in collaboration with L. Einkemmer (University of Innsbruck), a new splitting is proposed for solving the Vlasov-Maxwell system. This splitting is based on a decomposition of the Hamiltonian of the Vlasov-Maxwell system and allows for the construction of arbitrary high order methods by composition (independent of the specific deterministic method used for the discretization of the phase space). Moreover, we show that for a spectral method in space this scheme satisfies Poisson's equation without explicitly solving it. Finally, we present some examples in the context of the time evolution of an electromagnetic plasma instability which emphasizes the excellent behavior of the new splitting compared to methods from the literature.

5.8. A hybrid transport-diffusion model for radiative transfer in absorbing and scattering media

In [35], in collaboration with M. Roger (University of Lyon), C. Caliot (CNRS) and P. Coelho (Instituto Superior Tecnico of Lisboa), a new multi-scale hybrid transport-diffusion model for radiative transfer calculations is proposed. In this model, the radiative intensity is decomposed into a macroscopic component calculated by the diffusion equation, and a mesoscopic component. The transport equation for the mesoscopic component allows to correct the estimation of the diffusion equation, and then to obtain the solution of the linear radiative transfer equation. In this work, results are presented for stationary and transient radiative transfer cases, in examples which concern solar concentrated and optical tomography applications. The Monte Carlo and the discrete-ordinate methods are used to solve the mesoscopic equation. It is shown that the multi-scale model allows to improve the efficiency of the calculations when the medium is close to the diffusive regime. Moreover, the development of methods for coupling the radiative transfer equation with the diffusion equation becomes easier with this model than with the usual domain decomposition methods.

5.9. Charge conserving grid based methods for the Vlasov-Maxwell equations

In [26], in collaboration with P. Navaro (CNRS, Strasbourg) and E. Sonnendrücker (IPP Garching, Germany), In this article we introduce numerical schemes for the Vlasov-Maxwell equations relying on different kinds of grid based Vlasov solvers, as opposite to PIC schemes, that enforce a discrete continuity equation. The idea underlying this schemes relies on a time splitting scheme between configuration space and velocity space for the Vlasov equation and on the computation of the discrete current in a form that is compatible with the discrete Maxwell solver.

5.10. Improving conservation properties of a 5D gyrokinetic semi-Lagrangian code

In [32], in collaboration with G. Latu, V. Grandgirard, J. Abiteboul, G. Dif-Pradalier, X. Garbet, P. Ghendrih Y. Sarazin (IRFM, Cadarache), M. Mehrenberger (University of Strasbourg) and E. Sonnendrücker (IPP Garching, Germany), we are concerned with gyrokinetic turbulent simulations, where the knowledge of some stationary states can help reducing numerical artifacts. Considering long-term simulations, the qualities of the Vlasov solver and of the radial boundary conditions have an impact on the conservation properties. In order to improve mass and energy conservation mainly, the following methods are investigated: fix the radial boundary conditions on a stationary state, use a 4D advection operator that avoids a directional splitting, interpolate with a delta-f approach. The combination of these techniques in the semi-Lagrangian code gysela leads to a net improvement of the conservation properties in 5D simulations.

5.11. Simulations of Kinetic Electrostatic Electron Nonlinear (KEEN) Waves with Variable Velocity Resolution Grids and High-Order Time-Splitting

In [16], in collaboration with B. Afeyan (Polymath Research, USA), F. Casa (University Jaume, Spain), A. Dodhy, E. Sonnendrücker (IPP Garching, Germany) and M. Mehrenberger (University of Strasbourg), we are concerned with KEEN waves which are non-stationary, nonlinear, self-organized asymptotic states in Vlasov plasmas. They lie outside the precepts of linear theory or perturbative analysis, unlike electron plasma waves or ion acoustic waves. Steady state, nonlinear constructs such as BGK modes also do not apply. The range in velocity that is strongly perturbed by KEEN waves depends on the amplitude and duration of the ponderomotive force generated by two crossing laser beams, for instance, used to drive them. Smaller amplitude drives manage to devolve into multiple highly-localized vortclets, after the drive is turned off, and may eventually succeed to coalesce into KEEN waves. Fragmentation once the drive stops, and potential eventual remerger, is a hallmark of the weakly driven cases. A fully formed (more strongly driven) KEEN wave has one dominant vortical core. But it also involves fine scale complex dynamics due to shedding and merging of smaller vortical structures with the main one. Shedding and merging of vortclets are involved in either case, but at different rates and with different relative importance. The narrow velocity range in which one must maintain sufficient resolution in the weakly driven cases, challenges

fixed velocity grid numerical schemes. What is needed is the capability of resolving locally in velocity while maintaining a coarse grid outside the highly perturbed region of phase space. We here report on a new Semi-Lagrangian Vlasov-Poisson solver based on conservative non-uniform cubic splines in velocity that tackles this problem head on. An additional feature of our approach is the use of a new high-order time-splitting scheme which allows much longer simulations per computational effort. This is needed for low amplitude runs. There, global coherent structures take a long time to set up, such as KEEN waves, if they do so at all. The new code's performance is compared to uniform grid simulations and the advantages are quantified. The birth pains associated with weakly driven KEEN waves are captured in these simulations. Canonical KEEN waves with ample drive are also treated using these advanced techniques. They will allow the efficient simulation of KEEN waves in multiple dimensions, which will be tackled next, as well as generalizations to Vlasov-Maxwell codes. These are essential for pursuing the impact of KEEN waves in high energy density plasmas and in inertial confinement fusion applications. More generally, one needs a fully-adaptive grid-in-phase-space method which could handle all small vortclet dynamics whether peeling off or remerging. Such

fully adaptive grids would have to be computed sparsely in order to be viable. This two-velocity grid method is a concrete and fruitful step in that direction.

5.12. Gyroaverage operator on polar mesh

In [36], in collaboration with C. Steiner, M. Mehrenberger (University of Strasbourg) V. Grandgirard, G. Latu (IRFM, Cadarache). In this work, we are concerned with numerical approximation of the gyroaverage operators arising in plasma physics to take into account the effects of the finite Larmor radius corrections. The work initiated in [Crouseilles, Mehrenberger, Sellama, CiCP 2010] is extended here to polar geometries. A direct method is proposed in the space configuration which consists in integrating on the gyrocircles using interpolation operator (Hermite or cubic splines). Numerical comparisons with a standard method based on a Pade approximation are performed: (i) with analytical solutions, (ii) considering the 4D drift-kinetic model with one Larmor radius and (iii) on the classical linear DIII-D benchmark case [6]. In particular, we show that in the context of a drift-kinetic simulation, the proposed method has similar computational cost as the standard method and its precision is independent of the radius.

5.13. A new fully two-dimensional conservative semi-Lagrangian method: applications on polar grids, from diocotron instability to ITG turbulence

In [25], in collaboration with P. Glanc, S. Hirstoaga, E. Madaule, M. Mehrenberger, J. Pétri (University of Strasbourg), While developing a new semi-Lagrangian solver, the gap between a linear Landau run in 1d \times 1d and a 5D gyrokinetic simulation in toroidal geometry is quite huge. Intermediate test cases are welcome for checking the code. We consider here as building block, a 2D guiding-center type equation on an annulus. We first revisit a 2D test case previously done with a PIC approach and detail the boundary conditions. We then consider a 4D drift-kinetic slab simulation for which we give some first results of a new conservative method.

5.14. Uniformly accurate numerical schemes for highly oscillatory Klein-Gordon and nonlinear Schrödinger equations

In [21], we are interested in the numerical simulation of nonlinear Schrödinger and Klein-Gordon equations. We present a general strategy to construct numerical schemes which are uniformly accurate with respect to the oscillation frequency. This is a stronger feature than the usual so called "Asymptotic preserving" property, the last being also satisfied by our scheme in the highly oscillatory limit. Our strategy enables to simulate the oscillatory problem without using any mesh or time step refinement, and the orders of our schemes are preserved uniformly in all regimes. In other words, since our numerical method is not based on the derivation and the simulation of asymptotic models, it works in the regime where the solution does not oscillate rapidly, in the highly oscillatory limit regime, and in the intermediate regime with the same order of accuracy. The method is based on two main ingredients. First, we embed our problem in a suitable "two-scale" reformulation with the introduction of an additional variable. Then a link is made with classical strategies based on Chapman-Enskog expansions in kinetic theory despite the dispersive context of the targeted equations, allowing to separate the fast time scale from the slow one. Uniformly accurate (UA) schemes are eventually derived from this new formulation and their properties and performances are assessed both theoretically and numerically.

5.15. Asymptotic preserving schemes for the Wigner-Poisson-BGK equations in the diffusion limit

In [24], we focus on the numerical simulation of the Wigner-Poisson-BGK equation in the diffusion asymptotics. Our strategy is based on a "micro-macro" decomposition, which leads to a system of equations that couple the macroscopic evolution (diffusion) to a microscopic kinetic contribution for the fluctuations. A semi-implicit discretization provides a numerical scheme which is stable with respect to the small parameter ε (mean free path) and which possesses the following properties: (i) it enjoys the asymptotic preserving property in the diffusive limit; (ii) it recovers a standard discretization of the Wigner-Poisson equation in the collisionless regime. Numerical experiments confirm the good behaviour of the numerical scheme in both regimes. The case of a spatially dependent $\varepsilon(x)$ is also investigated.

5.16. Models of dark matter halos based on statistical mechanics: II. The fermionic King model

In [49] we study the fermionic King model which may provide a relevant model of dark matter halos. The exclusion constraint can be due to quantum mechanics (for fermions such as massive neutrinos) or to Lynden-Bells statistics (for collisionless systems undergoing violent relaxation). This model has a finite mass. Dwarf and intermediate size halos are degenerate quantum objects stabilized against gravitational collapse by the Pauli exclusion principle. Large halos at sufficiently high energies are in a gaseous phase where quantum effects are negligible. They are stabilized by thermal motion. Below a critical energy E_c they undergo gravitational collapse (gravothermal catastrophe). This may lead to the formation of a central black hole that does not affect the structure of the halo. This may also lead to the formation of a compact degenerate object surrounded by a hot massive atmosphere extending at large distances. We argue that large dark matter halos should not contain a degenerate nucleus (fermion ball) because these nucleus-halo structures are thermodynamically unstable. We compare the rotation curves of the classical King model to observations of large dark matter halos (Burkert profile). Because of collisions and evaporation, the central density increases while the slope of the halo density profile decreases until an instability takes place. We find that the observations are compatible with a King profile at, or close to, the point of marginal stability in the micro-canonical ensemble. At that point, the King profile can be fitted by the modified Hubble profile. This is qualitatively similar to the Burkert profile and discrepancies between the King model and the observations are interpreted as a result of incomplete relaxation.

5.17. Models of dark matter halos based on statistical mechanics: I. The classical King model

In [48] we consider the possibility that dark matter halos are described by the Fermi-Dirac distribution at finite temperature. This is the case if dark matter is a self-gravitating quantum gas made of massive neutrinos at statistical equilibrium. This is also the case if dark matter can be treated as a self-gravitating collisionless gas experiencing Lynden-Bell's type of violent relaxation. In order to avoid the infinite mass problem and carry out a rigorous stability analysis, we consider the fermionic King model. In this paper, we study the non-degenerate limit leading to the classical King model. This model was initially introduced to describe globular clusters and we propose to apply it also to large dark matter halos where quantum effects are negligible. We study the thermodynamical stability of the different configurations and compare the prediction of the classical King model to the observations of large dark matter halos. Because of collisions and evaporation, the central density increases while the slope of the halo density profile decreases until an instability takes place. We show that large dark matter halos are relatively well-described by the King model at, or close to, the point of marginal microcanonical stability. At that point, the King model generates a density profile that can be approximated by the modified Hubble profile. This profile has a flat core and decreases as r^{-3} at large distances, like the observational Burkert profile. For large halos, the flat core is due to finite temperature effects, not to quantum mechanics. We argue that statistical mechanics may provide a good description of dark matter halos and interpret the discrepancies as a result of incomplete relaxation like in the case of stellar systems.

5.18. Analysis of models for quantum transport of electrons in graphene layers

In [28], two mathematical models for the self consistent quantum transport of electrons in a graphene layer are presented and analyzed. We treat two situations. First, when the particles can move in all the plane R^2 , the model takes the form of a system of massless Dirac equations coupled together by a selfconsistent potential, which is the trace in the plane of the graphene of the 3D Poisson potential associated to surface densities. Second, we consider a situation where the particles are constrained in a regular bounded domain Ω . In order to take into account Dirichlet boundary conditions which are not compatible with the Dirac Hamiltonian H_0 , we propose a different model built on a modified Hamiltonian displaying the same energy band diagram as H_0 near the Dirac points.

5.19. Dimension reduction for anisotropic Bose-Einstein condensates in the strong interaction regime

The work [44] deals with the problem of dimension reduction for the three dimensional Gross-Pitaevskii equation (GPE) describing a Bose-Einstein condensate confined in a strongly anisotropic harmonic trap. Since the gas is assumed to be in a strong interaction regime, we have to analyze two combined singular limits: a semi-classical limit in the transport direction and the strong partial confinement limit in the transversal direction.

5.20. Superconvergence of Strang splitting for NLS in T^d

In [47], we investigate the convergence properties of semi-discretized approximations by Strang splitting method applied to fast-oscillating nonlinear Schrödinger equations. Our main contribution is to show that Strang splitting with constant step-sizes is unexpectedly more accurate by a factor ε as compared to established results when the step-size is chosen as an integer fraction of the period, owing to an averaging effect.

5.21. Strong confinement limit for the nonlinear Schrödinger equation constrained on a curve

The preprint [58] is devoted to the cubic nonlinear Schrödinger equation in a two dimensional waveguide with shrinking cross section of order ε . For a Cauchy data living essentially on the first mode of the transverse Laplacian, we provide a tensorial approximation of the solution ψ^ε in the limit $\varepsilon \rightarrow 0$, with an estimate of the approximation error, and derive a limiting nonlinear Schrödinger equation in dimension one with an additional effective potential depending on the curvature.

5.22. The fermionic King model

In [50], we study the fermionic King model which may provide a relevant model of dark matter halos.

5.23. Landau damping in Sobolev spaces for the Vlasov-HMF model

In [56], we consider the Vlasov-HMF (Hamiltonian Mean-Field) model. We consider solutions starting in a small Sobolev neighborhood of a spatially homogeneous state satisfying a linearized stability criterion (Penrose criterion). We prove that these solutions exhibit a scattering behavior to a modified state, which implies a nonlinear Landau damping effect with polynomial rate of damping.

5.24. Collisions of vortex filament pairs

In [18], we consider the problem of collisions of vortex filaments for a model introduced by Klein, Majda and Damodaran, and Zakharov to describe the interaction of almost parallel vortex filaments in three-dimensional fluids. Since the results of Crow examples of collisions are searched as perturbations of antiparallel translating pairs of filaments, with initial perturbations related to the unstable mode of the linearized problem; most results are numerical calculations. In this article we first consider a related model for the evolution of pairs of filaments and we display another type of initial perturbation leading to collision in finite time. Moreover we give numerical evidence that it also leads to collision through the initial model. We finally study the self-similar solutions of the model.

5.25. Asymptotic preserving schemes for the Klein-Gordon equation in the non-relativistic limit regime

In [30], we consider the Klein-Gordon equation in the non-relativistic limit regime, i.e. the speed of light c tending to infinity. We construct an asymptotic expansion for the solution with respect to the small parameter depending on the inverse of the square of the speed of light. As the first terms of this asymptotic can easily be simulated our approach allows us to construct numerical algorithms that are robust with respect to the large parameter c producing high oscillations in the exact solution.

5.26. Analysis of a large number of Markov chains competing for transitions

In [17], we consider the behavior of a stochastic system composed of several identically distributed, but non independent, discrete-time absorbing Markov chains competing at each instant for a transition. The competition consists in determining at each instant, using a given probability distribution, the only Markov chain allowed to make a transition. We analyze the first time at which one of the Markov chains reaches its absorbing state. When the number of Markov chains goes to infinity, we analyze the asymptotic behavior of the system for an arbitrary probability mass function governing the competition. We give conditions for the existence of the asymptotic distribution and we show how these results apply to cluster-based distributed systems when the competition between the Markov chains is handled by using a geometric distribution.

5.27. Coexistence phenomena and global bifurcation structure in a chemostat-like model with species-dependent diffusion rates

In [20], we study the competition of two species for a single resource in a chemostat. In the simplest space-homogeneous situation, it is known that only one species survives, namely the best competitor. In order to exhibit coexistence phenomena, where the two competitors are able to survive, we consider a space dependent situation: we assume that the two species and the resource follow a diffusion process in space, on top of the competition process. Besides, and in order to consider the most general case, we assume each population is associated with a distinct diffusion constant. This is a key difficulty in our analysis: the specific (and classical) case where all diffusion constants are equal, leads to a particular conservation law, which in turn allows to eliminate the resource in the equations, a fact that considerably simplifies the analysis and the qualitative phenomena. Using the global bifurcation theory, we prove that the underlying 2-species, stationary, diffusive, chemostat-like model, does possess coexistence solutions, where both species survive. On top of that, we identify the domain, in the space of the relevant bifurcation parameters, for which the system does have coexistence solutions.

5.28. Global behavior of N competing species with strong diffusion: diffusion leads to exclusion

In [46], we study the following problem. For a large class of models involving several species competing for a single resource in a *homogeneous* environment, it is known that the competitive exclusion principle holds: only one species survives eventually. Various works indicate though that coexistence of many species is possible when the competition occurs in a *heterogeneous* environment. We propose here a spatially heterogeneous system modeling several species competing for a single resource, and migrating in the spatial domain. For this model, it is known, at least in particular cases, that if migrations are *slow* enough, then coexistence occurs. In this paper we show at variance that if the spatial migrations are *fast* enough, then our system can be approximated by a spatially homogeneous system, called aggregated model, which can be explicitly computed, and we show that if the competitive exclusion principle holds for the aggregated model, then it holds as well for the original, spatially heterogeneous model. In other words, we show the persistence of the competitive exclusion principle in the spatially heterogeneous situation when migrations are fast. As a consequence, for fast migrations only one species may survive, namely the best competitor *in average*. We last study which is the best competitor *in average* on some examples, and draw some ecological consequences.

5.29. Randomized Message-Passing Test-and-Set

In [42] we present a solution to the well-known Test&Set operation in an asynchronous system prone to process crashes. Test&Set is a synchronization operation that, when invoked by a set of processes, returns yes to a unique process and returns no to all the others. Recently many advances in implementing Test&Set objects have been achieved, however all of them target the shared memory model. In this paper we propose an implementation of a Test&Set object in the message passing model. This implementation can be invoked by any number $p \leq n$ of processes where n is the total number of processes in the system. It has an

expected individual step complexity in $O(\log p)$ against an oblivious adversary, and an expected individual message complexity in $O(n)$. The proposed Test&Set object is built atop a new basic building block, called selector, that allows to select a winning group among two groups of processes. We propose a message-passing implementation of the selector whose step complexity is constant. We are not aware of any other implementation of the Test&Set operation in the message passing model.

5.30. Existence of densities for the 3D Navier–Stokes equations driven by Gaussian noise

In [27], we prove three results on the existence of densities for the laws of finite dimensional functionals of the solutions of the stochastic Navier-Stokes equations in dimension 3. In particular, under very mild assumptions on the noise, we prove that finite dimensional projections of the solutions have densities with respect to the Lebesgue measure which have some smoothness when measured in a Besov space. This is proved thanks to a new argument inspired by an idea introduced by N. Fournier and J. Printems.

5.31. Diffusion limit for the radiative transfer equation perturbed by a Markovian process

In [54], we study the stochastic diffusive limit of a kinetic radiative transfer equation, which is non linear, involving a small parameter and perturbed by a smooth random term. Under an appropriate scaling for the small parameter, using a generalization of the perturbed test-functions method, we show the convergence in law to a stochastic non linear fluid limit.

5.32. Diffusion limit for the radiative transfer equation perturbed by a Wiener process

In [55], we consider the rigorous derivation of a stochastic non-linear diffusion equation from a radiative transfer equation perturbed with a random noise of white noise type. The proof of the convergence relies on a formal Hilbert expansion and the estimation of the remainder. The Hilbert expansion has to be done up to order 3 to overcome some difficulties caused by the random noise.

MATHERIALS Team

5. New Results

5.1. Electronic structure calculations

Participants: Eric Cancès, Virginie Ehrlacher, David Gontier, Claude Le Bris, Gabriel Stoltz.

In electronic structure calculation as in most of our scientific endeavours, we pursue a twofold goal: placing the models on a sound mathematical grounding, and improving the numerical approaches.

E. Cancès and N. Mourad have mathematically analyzed the density functional perturbation theory, both in the non-degenerate case (that is, when the Fermi level is not an eigenvalue of the Kohn-Sham hamiltonian) and in the degenerate case. They have in particular proved that Wigner's $2n+1$ rule holds in both cases. D. Gontier has obtained a complete, explicit, characterization of the set of spin-polarized densities for finite molecular systems. This problem was left open in the pioneering work of von Barth and Hedin setting up the Kohn-Sham density functional theory for magnetic compounds. He has also extended a previous work by Anantharaman and Cancès, and proved the existence of minimizers for the spin-polarized Kohn-Sham model in the presence of a magnetic field within the local spin density approximation.

E. Cancès has pursued his long-term collaboration with Y. Maday (UPMC) on the numerical analysis of electronic structure models. With L. He (ENPC) and R. Chakir (IFSTTAR), they have designed and analyzed a two-grid methods for nonlinear elliptic eigenvalue problems, which can be applied, in particular, to the Kohn-Sham model. Some numerical tests demonstrating the interest of the approach have been performed with the Abinit software. Together with G. Dusson (UMPC), B. Stamm (UMPC), and M. Vohralík (Inria), they have designed a new post processing method for planewave discretizations of nonlinear Schrödinger equations, and used it to compute sharp *a posteriori* error estimators for both the discretization error and the algorithmic error (convergence threshold in the iterations on the nonlinearity).

Implicit solvation models aims at computing the properties of a molecule in solution (most chemical reactions take place in the liquid phase) by replacing all the solvent molecules but the few ones strongly interacting with the solute, by an effective continuous medium accounting for long-range electrostatics. E. Cancès, Y. Maday (Paris 6), and B. Stamm (Paris 6) have recently introduced a very efficient domain decomposition method for the simulation of large molecules in the framework of the so-called COSMO implicit solvation models. In collaboration with F. Lipparini (UPMC), B. Mennucci (Department of Chemistry, University of Pisa) and J.-P. Picquemail (Paris 6), they have implemented this algorithm in widely used computational software products (Gaussian and Tinker). The extension of this method to other implicit solvation models is work in progress.

Claude Le Bris, in collaboration with Pierre Rouchon (Ecole des Mines de Paris), has pursued the study of a new efficient numerical approach, based on a model reduction technique, to simulate high dimensional Lindblad type equations at play in the modelling of open quantum systems. The specific case under consideration is that of oscillation revivals of a set of atoms interacting resonantly with a slightly damped coherent quantized field of photons. The approach may be employed for other similar equations. Current work is directed towards other numerical challenges for this type of problems.

5.2. Computational Statistical Physics

Participants: Thomas Hudson, Frédéric Legoll, Tony Lelièvre, Mathias Rousset, Gabriel Stoltz.

The work of the team in this area is concentrated on two new directions: the sampling of reactive trajectories (where rare events dictate the dynamics of the system), and the computation of average properties of nonequilibrium systems (which completes the more traditional field of expertise associated with techniques to compute free energy differences).

5.2.1. Sampling of reactive trajectories

Finding trajectories for which the system undergoes a significant change is a challenging task since the transition events are typically very rare. Several methods have been proposed in the physics and chemistry literature, and members of the team have undertaken their study in the past years.

A prominent example is the parallel replica method where several replicas of the system evolve on different processors, until one of them undergoes a transition. Several extensions and refinements to the original method were proposed by T. Lelièvre:

- together with D. Aristoff and G. Simpson, he proposed in [7] an adaptation of the Parallel Replica method for Markov chains;
- together with A. Binder and G. Simpson, he introduced in [17] a generalized parallel replica dynamics. The idea is to extend the applicability of the original algorithm by computing on the fly the so-called decorrelation time.

Another class of techniques to compute reactive trajectories is based on splitting techniques. C.E. Bréhier, T. Lelièvre and M. Rousset have performed in [21] an analysis of the Adaptive Multilevel Splitting algorithm, which is a rare event simulation method where several replicas are evolved concurrently, and selected to favor exploration in a given direction. The computational cost of the algorithm is studied in details in the limit of a large number of replicas.

5.2.2. Nonequilibrium systems

G. Stoltz, together with G. Pavliotis (Imperial College) and Rémi Joubaud, studied in [27] the response of equilibrium systems evolving according to a Langevin dynamics, to external, space-time dependent forcings. In particular, they found out that, even if the external forcing is periodic in time and space with a vanishing space-time average, the systems in general evolves with a non-zero average velocity. It may even be the case that the average velocity is in the direction opposite to the average forcing (when the latter is non-zero), which can be seen as an example of negative mobility. The behavior of the system over diffusive time scales (in the reference frame obtained by removing the average velocity) is also studied, for arbitrary forcing strengths. This work was initiated when G. Pavliotis was a visiting member of the team MATHERIALS.

A numerical analysis of the error arising in the computation of transport coefficients, with an emphasis on mobility and self-diffusion, was provided by M. Fathi, A.A Homman and G. Stoltz in [25] in the case when Metropolis-Hastings algorithms are used to stabilize straightforward discretizations of overdamped Langevin dynamics.

Together with Herbert Spohn (TU München), G. Stoltz has verified the relevance of mode-coupling predictions for the scaling of space time correlations of invariants for one dimensional systems subjected to a non-reversible deterministic dynamics perturbed by an exchange noise [32]. In particular, it has been confirmed that the equilibrium relaxation of the invariants involves two modes, a traveling sound mode and a standing heat mode (related to the energy current and height autocorrelation functions). Both modes exhibit a superdiffusive scaling, of Lévy type for the heat mode, and of KPZ type for the sound mode.

5.2.3. Free energy computations

The topic of free energy computations is still a significant research area of the team. T. Lelièvre and G. Stoltz, together with G. Fort and B. Jourdain, studied the Self-Healing Umbrella Sampling (SHUS) method in [26]. This method is an adaptive biasing method to compute free energies on the fly by appropriately penalizing already visited regions. The convergence of the method relies on a rewriting as a stochastic approximation method with random steps, and can therefore be seen as a variation of the Wang-Landau method. The efficiency of the SHUS algorithm was assessed for a model two-dimensional system in terms of exit times out of a metastable set.

Concerning practical applications, G. Stoltz, together with A.A. Homman, E. Bourasseau, P. Malfreyt, L. Strafella and A. Ghoufi have worked on the computation of surface tension in droplets [10], using alchemical transformations where the droplet volume is artificially varied.

Finally, T. Lelièvre, together with J. Comer, J.C. Gumbart, J. Hénin, A. Pohorille and C. Chipot, wrote a review article on the adaptive biasing force method [9].

5.2.4. Thermodynamic limit

Another work in progress is related to the understanding of the origin of hysteresis in rubber-made materials. When submitted to cyclic deformations, the strain-stress curve of these materials indeed shows a hysteresis behavior, which seems to be independent of the speed of loading.

Some years ago, members of the team have suggested a model, at a mesoscale, to explain this behavior. This model was written in terms of a system made of a finite number of particles. One of the aim of the post-doc of Thomas Hudson, who joined the team in Sept. 2014, is to make progress on that question, and to understand whether a thermodynamic limit of the model previously proposed can be identified.

5.2.5. Reduced models

We propose in [13] a procedure for replacing a complex, reactive potential of REBO type by a simple harmonic approximation, in regions where the system is close to equilibrium. The parameters of the harmonic approximation are chosen so that the phonon spectrum is exactly reproduced. We are currently testing the ability of the so-obtained hybrid model to predict the fracture of graphene.

5.3. Complex fluids

Participants: Sébastien Boyaval, Claude Le Bris, Tony Lelièvre.

Sébastien Boyaval has pursued his research about the mathematical modelling of complex free-surface flows. On the one hand, the numerical investigation of 3D effects with a VOF approach was carried out for multiphase flows in collaboration with the CFSFlow code developers at EPFL [11]. On the other hand, the reduced modelling of viscoelastic effects within Saint-Venant framework was carried out for asymptotically thin layers above rough bottoms [8].

5.4. Application of greedy algorithms

Participants: Sébastien Boyaval, Eric Cancès, Virginie Ehrlacher, Tony Lelièvre.

Model reduction techniques are very important tools for applications. They consist in deriving from a high-dimensional problem, a low-dimensional model, which very quickly gives reliable results. In particular, the team is interested in two techniques: Proper Generalized Decomposition (greedy algorithms) and Reduced Basis techniques.

Eric Cancès, Virginie Ehrlacher and Tony Lelièvre have extended a greedy algorithm suggested for the resolution of high-dimensional eigenvalue problems in order to approximate the solution of the many-body Schrödinger electronic problem. The main technical difficulty in the extension of these algorithms lies in the antisymmetry of the wavefunction of the electrons. To deal with this difficulty, an approximation of the wavefunction is computed as a sum of Slater determinants, each Slater determinant function being computed in an iterative way.

Virginie Ehrlacher has obtained preliminary encouraging results on greedy algorithms for parametric eigenvalue problems. The method has been applied to the computation of the first buckling mode of a plate in the presence of a defect, the position of the defect playing the role of a parameter entering the eigenvalue problem defining the first buckling mode of the plate.

A new numerical method for the construction of an efficient reduced-order model for the solution of the Vlasov equation, arising in plasma physics or in the modeling of electron transport in semiconductors, has been tested by Damiano Lombardi (REO Inria team) and Virginie Ehrlacher. This method is based on the use of an analytic Lax Pair for the Vlasov equations and is inspired by previous works done on transport equations by Jean-Frederic Gerbeau, Damiano Lombardi and Elisa Schenone. Encouraging preliminary numerical results have been obtained.

5.5. Homogenization and related topics

Participants: Sébastien Brisard, Ludovic Chamoin, Virginie Ehrlacher, Claude Le Bris, Frédéric Legoll, Simon Lemaire, François Madiot, William Minvielle.

The homogenization of (deterministic) non periodic systems is a well known topic. Although well explored theoretically by many authors, it has been less investigated from the standpoint of numerical approaches (except in the random setting). In collaboration with X. Blanc and P.-L. Lions, C. Le Bris has introduced a possible theory, giving rise to a numerical approach, for the simulation of multiscale nonperiodic systems. The theoretical considerations are based on earlier works by the same authors (derivation of an algebra of functions appropriate to formalize a theory of homogenization). The numerical endeavour is completely new. The theoretical results obtained to date are being collected in a series of manuscripts that will be available shortly.

The team has pursued its efforts in the field of stochastic homogenization of elliptic equations, aiming at designing numerical approaches that both are practically relevant and keep the computational workload limited.

Using the standard homogenization theory, one knows that the homogenized tensor, which is a deterministic matrix, depends on the solution of a stochastic equation, the so-called corrector problem, which is posed on the *whole* space \mathbb{R}^d . This equation is therefore delicate and expensive to solve. In practice, the space \mathbb{R}^d is truncated to some bounded domain, on which the corrector problem is numerically solved. In turn, this yields a converging approximation of the homogenized tensor, which happens to be a *random* matrix.

In [28], F. Legoll and W. Minvielle have proposed a variance reduction procedure, based on the control variate technique, to obtain estimates of the apparent homogenized tensor with a smaller statistical error (at a given computational cost) than standard Monte Carlo approaches. The control variate technique is based on using a surrogate model, somewhat in the spirit of a preconditionner. In [28], the surrogate model that is used is inspired by a weakly stochastic approach previously introduced by A. Anantharaman and C. Le Bris to describe periodic models perturbed by rare defects.

In addition, C. Le Bris, F. Legoll and W. Minvielle have investigated the possibility to use another variance reduction technique based on computing the corrector equation only for selected environments. These environments are chosen based on the fact that their statistics in the finite supercell matches the statistics of the materials in the infinite supercell. This method yields an estimator with a smaller variance than standard estimators. Preliminary encouraging numerical results have been obtained.

As pointed out above, the corrector problem is in practice solved on a large bounded domain, often complemented with periodic boundary conditions. Solving that problem can still be challenging, in particular because producing a conforming mesh of realistic heterogeneous microstructures can be a daunting task. In such situations, numerical methods formulated on cartesian grids may be more interesting. These methods can still be Finite Element Methods, or methods in the spirit of that proposed by Moulinec and Suquet in the mid-nineties. In their approach, the corrector problem (a partial differential equation) is reformulated as an equivalent integral equation. This equation can readily be discretized using a Galerkin approach. This leads to numerical schemes that can be implemented as a matrix-free method. In [18], S. Brisard and F. Legoll have reviewed the different variants that have been proposed in the literature along these ideas, and proposed a mathematical analysis of the numerical schemes. This work extends in various directions previous works by S. Brisard.

In somewhat the same vein, Eric Cancès, Virginie Ehrlacher and Frédéric Legoll (in collaboration with Benjamin Stamm, University Paris 6) have worked on alternative methods to approximate the homogenized coefficients of a random stationary material. These methods are alternative to those proposed e.g. by Bourgeat and Piatniski, and which consist in solving a corrector problem on a bounded domain. The method introduced is based on a new corrector problem. This problem is posed on the entire space. In some cases (including the case of randomly located spherical inclusions), it can be recast as an integral equation posed on the surface of the inclusions. The problem can then be efficiently solved via domain decomposition and using spherical harmonics.

We have discussed above approaches to efficiently compute the homogenized coefficient, assuming we have a complete knowledge of the microstructure of the material. We have actually also considered a related inverse problem, and more precisely a parameter fitting problem. Knowing the homogenized quantities, is it possible to recover some features of the microstructure properties? Obviously, since homogenization is an averaging procedure, not everything can be recovered from macroscopic quantities. A realistic situation is the case when a functional form of the distribution of the microscopic properties is assumed, but with some unknown parameters to determine. In collaboration with A. Obliger and M. Simon, F. Legoll and W. Minvielle have addressed that problem in [29], showing how to determine the unknown parameters of the microscopic distribution on the basis of macroscopic (e.g. homogenized) quantities.

From a numerical perspective, the Multiscale Finite Element Method (MsFEM) is a classical strategy to address the situation when the homogenized problem is not known (e.g. in difficult nonlinear cases), or when the scale of the heterogeneities, although small, is not considered to be zero (and hence the homogenized problem cannot be considered as an accurate enough approximation).

The MsFEM has been introduced more than 10 years ago. However, even in simple deterministic cases, there is actually still room for improvement in many different directions. In collaboration with A. Lozinski (University of Besançon), F. Legoll and C. Le Bris have introduced and studied a variant of MsFEM that considers Crouzeix-Raviart type elements on each mesh element. The continuity across edges (or facets) of the (multiscale) finite element basis set functions is enforced only weakly, using fluxes rather than point values. That approach has been analyzed and tested on an elliptic problem set on a domain with a huge number of perforations. The variant developed outperforms all existing variants of MsFEM.

A follow up on this work, in collaboration with U. Hetmaniuk (University of Washington in Seattle) and A. Lozinski (University of Besançon), consists in the study of multiscale advection-diffusion problems. Such problems are possibly advection dominated and a stabilization procedure is therefore required. How stabilization interplays with the multiscale character of the equation is an unsolved mathematical question worth considering for numerical purposes. In that spirit, C. Le Bris, F. Legoll and F. Madiot have studied several variants of the Multiscale Finite Element Method (MsFEM), specifically designed to address multiscale advection-diffusion problems in the convection-dominated regime. Generally speaking, the idea of the MsFEM is to perform a Galerkin approximation of the problem using specific basis functions, that are precomputed (in an offline stage) and adapted to the problem considered. Several possibilities for the basis functions have been examined (for instance, they may or may not encode the convection field). The various approaches have been compared in terms of accuracy and computational costs.

Most of the numerical analysis studies of the MsFEM are focused on obtaining *a priori* error bounds. In collaboration with L. Chamoin, who is currently in delegation in our team (from ENS Cachan, since September 2014), we have started to work on *a posteriori* error analysis for MsFEM approaches, with the aim to develop error estimation and adaptation tools. We have extended to the MsFEM case an approach that is classical in the computational mechanics community for single scale problems, and which is based on the so-called Constitutive Relation Error (CRE). Once a numerical solution u_h has been obtained, the approach needs additional computations in order to determine a divergence-free field as close as possible to the exact flux $k\nabla u$. In the context of the MsFEM, it is important to be able to do all the expensive computations in an offline stage, independently of the right-hand side. The standard CRE approach thus needs to be adapted to that context, in order to keep that feature that makes it adapted to a multiscale, multi-query context. The preliminary approach that we have introduced already yields promising results.

Still another question investigated in the group is to find an alternative to standard homogenization techniques when these latter are difficult to use in practice. This is the aim of the post-doc of Simon Lemaire, which began in June 2014, and which takes over previous works of the group on the subject. Consider a linear elliptic equation, say in divergence form, with a highly oscillatory matrix coefficient, and assume that this problem is to be solved for a large number of right-hand sides. If the coefficient oscillations are infinitely rapid, the solution can be accurately approximated by the solution to the homogenized problem, where the homogenized coefficient has been evaluated beforehand by solving the corrector problem. If the oscillations are moderately rapid, one can think instead of MsFEM-type approaches to approximate the solution to the

reference problem. However, in both cases, the complete knowledge of the oscillatory matrix coefficient is required, either to build the average model or to compute the multiscale basis. In many practical cases, this coefficient is often only partially known, or merely completely unavailable, and one only has access to the solution of the equation for some loadings. This observation has led to think about alternative methods, in the following spirit. Is it possible to approximate the reference solution by the solution to a problem with a *constant* matrix coefficient? How can this 'best' constant matrix approximating the oscillatory problem be constructed in an efficient manner?

A preliminary step, following discussion and interaction with A. Cohen, has been to cast the problem as a convex optimization problem. We have then shown that the 'best' constant matrix defined as the solution of that problem converges to the homogenized matrix in the limit of infinitely rapidly oscillatory coefficients. Furthermore, the optimization problem being convex, it can be efficiently solved using standard algorithms. C. Le Bris, F. Legoll and S. Lemaire are currently working on making the resolution of the optimization problem as efficient as possible.

To conclude this section, we mention a project involving V. Ehrlacher, C. Le Bris and F. Legoll, in collaboration with G. Leugering and M. Stingl (Cluster of Excellence, Erlangen-Nuremberg University). This project aims at optimizing the shape of some materials (modelled as structurally graded linear elastic materials) in order to achieve the best mechanical response at the minimal cost. As often the case in shape optimization, the solution tends to be highly oscillatory, thus the need of homogenization techniques. Materials under consideration are being thought of as microstructured materials composed of steel and void and whose microstructure patterns are constructed as the macroscopic deformation of a reference periodic microstructure. The optimal material (i.e. the best macroscopic deformation) is the deformation achieving the best mechanical response. For a given deformation, we have first chosen to compute the mechanical response using a homogenized model. We are currently aiming at computing the mechanical response at the microscale, using the highly oscillatory model. Model reduction techniques (such as MsFEM, Reduced Basis methods, ...) are then in order, in order to expedite the resolution of the oscillatory problem, which has to be solved at each loop of the optimization algorithm. Current efforts are targeted towards choosing an appropriate model reduction strategy.

5.6. Miscellaneous

Participants: Sébastien Boyaval, Tony Lelièvre, Sébastien Boyaval.

T. Lelièvre together with F. Casenave and A. Ern propose in [24] an extension of the classical reduced basis method in order to extend its range of applicability to black-box codes.

S. Boyaval started investigating new high-order methods on generalized non-conforming meshes in collaboration with Daniele di Pietro [14].

In [31], M. Rousset considers space homogenous Boltzmann kinetic equations in dimension $d \geq 3$ with Maxwell collisions (and without Grad's cut-off). An explicit Markov coupling of the associated conservative stochastic N-particle system is constructed, yielding a N-uniform α -power law trend to equilibrium.

MC2 Team

6. New Results

6.1. Highlights of the Year

- **Models for gliomas**
Glioblastoma multiforme (GBM) causes significant neurological morbidity and short survival times. Brain invasion by GBM is associated with poor prognosis. Recent clinical trials of bevacizumab in newly-diagnosed GBM found no beneficial effects on overall survival times; however, the baseline health-related quality of life and performance status were maintained longer in the bevacizumab group and the glucocorticoid requirement was lower. In a recent work in collaboration with UAB, we have constructed a clinical-scale model of GBM whose predictions uncover a new pattern of recurrence in 11/70 bevacizumab-treated patients. The findings support an exception to the Folkman hypothesis: GBM grows in the absence of angiogenesis by a cycle of proliferation and brain invasion that expands necrosis. Furthermore, necrosis is positively correlated with brain invasion in 26 newly-diagnosed GBM. The unintuitive results explain the unusual clinical effects of bevacizumab and suggest new hypotheses on the dynamic clinical effects of migration by active transport, a mechanism of hypoxia-driven brain invasion.
- **Electroporation modeling** (M. Leguebe, C. Poinard)
Based on the new discovery of the team of Vectorolgy and anti-cancerous therapies on the membrane lipid oxidation during the pulse delivery, we have provided a model of cell permeabilization that makes it possible to explain the process of electroporation : pore formation during the pulse and surface diffusion of altered lipids after the pulse. Our model explains the long-term effect of electroporation (the permeable state of the membrane lasts a few minutes after the pulse delivery). A 3D-code in C++ has been implemented during the PhD thesis of M. Leguèbe. The team MC2 is now part of the European Lab EBAM on electroporation modeling. An international workshop on Electroporation and Biophysical Therapies was held in Bordeaux the 15th and 16th December.
- Simulation of **multiphysic fluid-structure impacts in 3D**. See <http://www.math.u-bordeaux1.fr/adebrauer/> for astinishing videos.

6.2. Cancer modeling

- **Patient specific simulation for lung metastases**
The calibration process has tremendously improved by a deep study of the model and its parameter space. Work is ongoing to validate the whole process on a retrospective study of 30 patients. A prototype is being built for our collaborators at Institut Bergonié to use in their clinical routine. The same strategy has been applied to meningiomas in the last year of the post-doc of Julie Joie within the IRL MONICA with a retrospective study on 10 patients.
- Modelling of the response to targeted therapies for liver metastasis of a gist : 2 clinical cases with a long term longitudinal follow-up with CT-scans. We are able to fit the volume of the lesion but also the the texture of the image, that is the ratio between necrotic tissues and proliferative ones. See [82].
- Tumor growth model for ductal carcinoma: from in situ phase to stroma invasion. See [71].
- Permeable and conducting states of membrane submitted to electric pulse: non-linear PDE model, 2D and 3D code in C++.
- Free boundary value model for invadopodia and migration of cell developed in collaboration with Osaka University and Tokyo University of Sciences.
- Endothelial cell migration on polymers: agent based model. Paper accepted in DCDS-B.

- A. Peretti started her PhD on the modeling of the heterogeneity on renal cancer.
- Benjamin Taton started a post-doc on the modeling of the renal function through perfusion MRI. B. Taton is a MD.
- Th. Michel obtained some mathematical properties on the system of PDEs used for the modelling of GIST metastases.
- **Models for preclinical studies**
 - Mathematical **ODE models of tumor volume kinetics in mice** (collaboration with the Center of Cancer and Systems Biology, Boston, USA and J. Ebos, Roswell Park Cancer Institute, Buffalo, USA).
Rational and quantitative evaluation of the predictive and descriptive power of the majority of the classical ODE models for tumor growth against data from two distinct experimental systems [57]. One of the major finding was the huge improvement of the predictive properties when using the population *a priori* information on the distribution of the parameters.
 - Mathematical model for data of **preclinical metastatic burden dynamics** and clinical data of metastatic relapse probability of **breast cancer** (collaboration with J. Ebos, Roswell Park Cancer Institute, Buffalo, USA).
Validation of the descriptive and predictive ability of a simple and minimally parameterized model. The major finding resulting from the modeling analysis was the quantification of the impact of surgery on survival improvement (highly nonlinear), which suggests a threshold primary tumor size for efficacy of the surgery in terms of preventing metastatic recurrence. A publication is in preparation.
 - Effect of **anti-cancer therapies** in preclinical experiments
 - * Evaluation of several models (several already published but also new ones) for the effect of **anti-angiogenic drugs**⁰ on tumor growth, based on statistical parameter estimation methods on experimental data (collaboration with J. Ebos, Roswell Park Cancer Institute, Buffalo, USA). The main finding was one model that was able to both describe the effect of the drug (Sunitinib) and predict the effect when changing the scheduling. See [66].
 - * Effect of the **sequence of administration between cytotoxic and anti-angiogenic drugs** (collaboration with J. Ciccolini and D. Barbolosi, SMARTc, Inserm, Marseille, Fr). See [84].
- **Theoretical cancer biology**
 - Theories of metastatic initiation (collaboration with A. Bikfalvi, LAMC, Inserm and the RMSB, CNRS in Bordeaux, Fr).
Confrontation of theories and experimental data challenged the classical view of metastatic establishment and growth and suggested that tumors could merge in initial phases. Quantitative impact of the merging was studied using a dedicated and properly calibrated spatial model.
 - Tumor-tumor distant interactions (collaboration with the Center of Cancer and Systems Biology, Boston, USA).
Statistical and modeling analysis of experimental data for two tumors implanted in one organism.

⁰recent anti-cancer drugs that target the tumor vasculature rather than the cancer cells themselves

6.3. Newtonian fluid flows simulations and their analysis

- Development of a high-order (third order in time and space) level-set method which allow to compute consistently the curvature of the interface even for long times (L. Weynans, F. Luddens and M. Bergmann)
- Development of a sharp cartesian method for the simulation of incompressible flows with high density ratios, like air-water interfaces. This method is inspired from the second-order cartesian method for elliptic problems with immersed interfaces developed in Cisternino-Weynans [69]
- Study of the convergence in 1D and 2D of the method developed in Cisternino-Weynans [69]

MEPHYSTO Team

6. New Results

6.1. Highlights of the Year

A. Gloria, S. Neukamm, and F. Otto published their recent contribution [17] on quantitative homogenization in *Inventiones Mathematicae*.

As a plenary speaker of the World Congress of Computational Mechanics in Barcelone in July 2014, P. Le Tallec (Ecole polytechnique) presented our joint results [15], [25].

6.2. Quantitative stochastic homogenization

A. Gloria, S. Neukamm (Univ. Dresden), and F. Otto (MPI for mathematics in the sciences, Leipzig) developed in [17] a general approach to quantify ergodicity in stochastic homogenization of discrete elliptic equations. Using a parabolic approach, they obtained optimal estimates on the time-decay of the so-called environment seen from the particle. This allowed them to prove optimal bounds on the corrector gradient and the corrector itself in any dimension (thus improving on [4]). They also obtained the first error analysis of the popular periodization method to approximate the homogenized coefficients.

In [32], A. Gloria and F. Otto extended their results [4], [5] on discrete elliptic equations to the continuum setting. They treated in addition the case of non-symmetric coefficients, and obtained optimal estimates in all dimensions by the elliptic approach (whereas [4], [5] were suboptimal for $d = 2$).

In [28], A. Gloria and D. Marahrens (MPI for mathematics in the sciences, Leipzig) extended the annealed results [51] on the discrete Green function by D. Marahrens and F. Otto to the continuum setting. As a by-product of their result, they obtained new results in uncertainty quantification by estimating optimally the variance of the solution of an elliptic PDE whose coefficients are perturbed by some noise with short range of dependence.

In their recent work [29], A. Gloria, S. Neukamm, and F. Otto developed a regularity theory for random elliptic operators inspired by the contributions of Avellaneda and Lin [39] in the periodic setting and of our visitor S. Armstrong with C. Smart [38]. This allowed them to consider coefficients with arbitrarily slow decaying correlations in the form of a family of correlated Gaussian fields.

In [30], A. Gloria and J. Nolen (Duke Univ.) proved a quantitative central limit theorem for the effective conductance on the discrete torus. In particular, they quantified the Wasserstein distance between a normal random variable and the CLT-like rescaling of the difference between the approximation of the effective conductance by periodization and the effective conductance. Their estimate is sharp and shows that the Wasserstein distance goes to zero (up to logarithmic factors) as if the energy density of the corrector was iid (which it is not). This completes and settles the analysis started in [17] on the approximation of homogenized coefficients by periodization by characterizing the limiting law in addition to the scaling.

6.3. Derivation of nonlinear elasticity from polymer-physics

In [15], A. Gloria, P. Le Tallec (Mechanics department, Ecole polytechnique), and M. Vidsrascu (Project-team REO, Inria) numerically investigated the nonlinear elasticity model obtained in [1] by discrete stochastic homogenization, and compared it to the standard measurements by Treloar on natural rubber. The implementation was realized in the *Modulef* software. These results are in rather good agreement, which shows that the approach seems to be promising.

In [25], M. de Buhan (CNRS, Univ. Paris Descartes), A. Gloria, P. Le Tallec and M. Vidrascu proposed a numerical method to produce analytical approximations (that can be used in practical nonlinear elasticity softwares) of the numerical approximations obtained in [15] of the discrete-to-continuum energy density derived theoretically in [1]. This numerical method is based on the parametrization of the set of polyconvex Ogden laws and on the combination of a least square method and a genetic algorithm (cf. CMA-ES).

6.4. Numerical homogenization

Inspired by the quantitative analysis of [17] and [48], Z. Habibi (former SIMPAF post-doctoral fellow) and A. Gloria introduced in [14] a general method to reduce the so-called resonance error in numerical homogenization, both at the levels of the approximation of the homogenized coefficients and of the correctors. This method significantly extends [2]. The method relies on the introduction of a massive term in the corrector equation and of a systematic use of Richardson extrapolation. In the three academic examples of heterogeneous coefficients (periodic, quasiperiodic, and Poisson random inclusions), the method yields optimal theoretical and empirical convergence rates, and outperforms most of the other existing methods.

6.5. Nonlinear Schrödinger equation

S. De Bièvre, S. Rota Nodari (CEMPI postdoc 2013-2015) and F. Genoud (CEMPI visitor, September 2013) have explained the geometry underlying the so-called energy-momentum method for proving orbital stability in infinite dimensional Hamiltonian systems. Applications include the orbital stability of solitons of the NLS and Manakov equations. This work is to appear as a chapter (120p) in the first volume of the CEMPI Lecture Notes in Mathematics, cf. [24].

6.6. Kicked rotors

S. De Bièvre and his PhD student E. Soret rigorously proved the growth rate of the energy in a Markovian model for stochastic acceleration of a particle in a random medium, cf. [34].

6.7. Time integration of Hamiltonian system with noise

G. Dujardin introduced an energy preserving method for Hamiltonian dynamics perturbed by a multiplicative noise, cf. [11].

6.8. Miscellaneous results

The MEPHYSTO team is currently hosting former members of the project-team SIMPAF who focus on numerical methods for dissipative systems:

- corrosion models [19], [23],
- fluid mechanics [9], [21], [27], [10],
- numerical analysis for asymptotic preserving properties [8], [7],
- a posteriori estimates [20].

T. Gallouët also made contributions in optimal transport [22], [26].

MOKAPLAN Team

6. New Results

6.1. Highlights of the Year

All of the new results below are important break through and most of them non-incremental research.

Mokaplan has extended its collaborations to several researchers at Ceremade and is under review to become a project team.

6.2. Iterative Bregman Projections for Regularized Transportation Problems

Benamou, Jean-David and Carlier, Guillaume and Cuturi, Marco and Nenna, Luca and Peyré, Gabriel

[19]

We provide a general numerical framework to approximate solutions to linear programs related to optimal transport. The general idea is to introduce an entropic regularization of the initial linear program. This regularized problem corresponds to a Kullback-Leibler Bregman divergence projection of a vector (representing some initial joint distribution) on the polytope of constraints. We show that for many problems related to optimal transport, the set of linear constraints can be split in an intersection of a few simple constraints, for which the projections can be computed in closed form. This allows us to make use of iterative Bregman projections (when there are only equality constraints) or more generally Bregman-Dykstra iterations (when inequality constraints are involved). We illustrate the usefulness of this approach to several variational problems related to optimal transport: barycenters for the optimal transport metric, tomographic reconstruction, multi-marginal optimal transport and in particular its application to Brenier's relaxed solutions of in-compressible Euler equations, partial unbalanced optimal transport and optimal transport with capacity constraints.

The extension of the method to the Principal Agent problem, Density Functional theory and Transport under martingal constraint is under way.

6.3. A viscosity framework for computing Pogorelov solutions of the Monge-Ampere equation

Benamou, Jean-David and Froese, Brittany D.

[21]

We consider the Monge-Kantorovich optimal transportation problem between two measures, one of which is a weighted sum of Diracs. This problem is traditionally solved using expensive geometric methods. It can also be reformulated as an elliptic partial differential equation known as the Monge-Ampere equation. However, existing numerical methods for this non-linear PDE require the measures to have finite density. We introduce a new formulation that couples the viscosity and Aleksandrov solution definitions and show that it is equivalent to the original problem. Moreover, we describe a local reformulation of the subgradient measure at the Diracs, which makes use of one-sided directional derivatives. This leads to a consistent, monotone discretisation of the equation. Computational results demonstrate the correctness of this scheme when methods designed for conventional viscosity solutions fail.

The method offers a new insight into the duality between Aleksandrov and Brenier solutions of the Monge Ampère equations. We still work on the viscosity existence/uniqueness convergence of scheme theory.

6.4. Discretization of functionals involving the Monge-Ampère operator

Benamou, Jean-David and Carlier, Guillaume and Mérigot, Quentin and Oudet, Edouard

[26]

Gradient flows in the Wasserstein space have become a powerful tool in the analysis of diffusion equations, following the seminal work of Jordan, Kinderlehrer and Otto (JKO). The numerical applications of this formulation have been limited by the difficulty to compute the Wasserstein distance in dimension larger than 2. One step of the JKO scheme is equivalent to a variational problem on the space of convex functions, which involves the Monge-Ampère operator. Convexity constraints are notably difficult to handle numerically, but in our setting the internal energy plays the role of a barrier for these constraints. This enables us to introduce a consistent discretization, which inherits convexity properties of the continuous variational problem. We show the effectiveness of our approach on nonlinear diffusion and crowd-motion models.

6.5. Augmented Lagrangian methods for transport optimization, Mean-Field Games and degenerate PDEs

Benamou, Jean-David and Carlier, Guillaume

[18]

Many problems from mass transport can be reformulated as variational problems under a prescribed divergence constraint (static problems) or subject to a time dependent continuity equation which again can also be formulated as a divergence constraint but in time and space. The variational class of Mean-Field Games introduced by Lasry and Lions may also be interpreted as a generalisation of the time-dependent optimal transport problem. Following Benamou and Brenier, we show that augmented Lagrangian methods are well-suited to treat convex but nonsmooth problems. It includes in particular Monge historic optimal transport problem. A Finite Element discretization and implementation of the method is used to provide numerical simulations and a convergence study.

We have good hopes to use this method to many non-linear diffusion equations through the use of JKO gradient schemes.

6.6. Discretization of functionals involving the Monge-Ampère operator

Benamou, Jean-David and Collino, Francis and Mirebeau, Jean-Marie

[20]

We introduce a novel discretization of the Monge-Ampère operator, simultaneously consistent and degenerate elliptic, hence accurate and robust in applications. These properties are achieved by exploiting the arithmetic structure of the discrete domain, assumed to be a two dimensional cartesian grid. The construction of our scheme is simple, but its analysis relies on original tools seldom encountered in numerical analysis, such as the geometry of two dimensional lattices, and an arithmetic structure called the Stern-Brocot tree. Numerical experiments illustrate the method's efficiency.

6.7. A Γ -Convergence Result for the Upper Bound Limit Analysis of Plates

Bleyer, Jérémy and Carlier, Guillaume and Duval, Vincent and Mirebeau, Jean-Marie and Peyré, Gabriel

[23]

Upper bound limit analysis allows one to evaluate directly the ultimate load of structures without performing a cumbersome incremental analysis. In order to numerically apply this method to thin plates in bending, several authors have proposed to use various finite elements discretizations. We provide in this paper a mathematical analysis which ensures the convergence of the finite element method, even with finite elements with discontinuous derivatives such as the quadratic 6 node Lagrange triangles and the cubic Hermite triangles. More precisely, we prove the Gamma-convergence of the discretized problems towards the continuous limit analysis problem. Numerical results illustrate the relevance of this analysis for the yield design of both homogeneous and non-homogeneous materials.

6.8. Cournot-Nash equilibria

Carlier, Guillaume and Blanchet, Adrien

[24]

The notion of Nash equilibria plays a key role in the analysis of strategic interactions in the framework of N player games. Analysis of Nash equilibria is however a complex issue when the number of players is large. It is therefore natural to investigate the continuous limit as N tends to infinity and to investigate whether it corresponds to the notion of Cournot-Nash equilibria. In [9], this kind of convergence result is studied in a Wasserstein framework. In [BC1], we go one step further by giving a class of games with a continuum of players for which equilibria may be found as minimizers as a functional on measures which is very similar to the one-step JKO case, uniqueness results are the obtained from displacement convexity arguments. Finally, in [9] some situations which are non variational are considered and existence is obtained by methods combining fixed point arguments and optimal transport.

6.9. Principal Agent

Carlier, Guillaume, Benamou, Jean-David and Dupuis Xavier

The numerical resolution of principal Agent for a bilinear utility has been attacked and solved successfully in a series of recent papers see [70] and references therein.

A Bregman approach inspired by [6] has been developed for more general functions the paper is currently being written. It would be extremely useful as a complement to the theoretical analysis. A new semi-Discrete Geometric approach is also investigated where the method reduces to non-convex polynomial optimization.

6.10. Exact Support Recovery for Sparse Spikes Deconvolution

Duval, Vincent and Peyré, Gabriel

[17]

We study sparse spikes deconvolution over the space of measures. We focus our attention to the recovery properties of the support of the measure, i.e. the location of the Dirac masses. For non-degenerate sums of Diracs, we show that, when the signal-to-noise ratio is large enough, total variation regularization (which is the natural extension of the L1 norm of vectors to the setting of measures) recovers the exact same number of Diracs. We also show that both the locations and the heights of these Diracs converge toward those of the input measure when the noise drops to zero. The exact speed of convergence is governed by a specific dual certificate, which can be computed by solving a linear system. We draw connections between the support of the recovered measure on a continuous domain and on a discretized grid. We show that when the signal-to-noise level is large enough, the solution of the discretized problem is supported on pairs of Diracs which are neighbors of the Diracs of the input measure. This gives a precise description of the convergence of the solution of the discretized problem toward the solution of the continuous grid-free problem, as the grid size tends to zero.

NACHOS Project-Team

6. New Results

6.1. Electromagnetic wave propagation

6.1.1. Numerical study of the 1d nonlinear Maxwell equations

Participants: Loula Fézoui, Stéphane Lanteri.

The system of Maxwell equations describes the evolution of the interaction of an electromagnetic field with a propagation medium. The different properties of the medium, such as isotropy, homogeneity, linearity, among others, are introduced through *constitutive laws* linking fields and inductions. In the present study, we focus on nonlinear effects and address nonlinear Kerr materials specifically. In this model, any dielectric may become nonlinear provided the electric field in the material is strong enough. As a first step, we consider the one-dimensional case and study the numerical solution of the nonlinear Maxwell equations thanks to DG methods. In particular, we make use of an upwind scheme and limitation techniques because they have a proven ability to capture shocks and other kinds of singularities in the fluid dynamics framework. The numerical results obtained in this preliminary study gives us confidence towards extending this work to higher spatial dimensions.

6.1.2. High order geometry conforming method for nanophotonics

Participants: Stéphane Lanteri, Claire Scheid, Jonathan Viquerat.

Usually, unstructured mesh based methods rely on tessellations composed of straight-edged elements mapped linearly from a reference element, on domains which physical boundaries are indifferently straight or curved. Such meshes represent a serious hindrance for high order finite element (FE) methods since they limit the accuracy to second order in the spatial discretization. Thus, exploiting an enhanced representation of physical geometries is in agreement with the natural procedure of high order FE methods, such as the DG method. There are several ways to account for curved geometries. One could choose to incorporate the knowledge coming from CAD in the method to design the geometry and the approximation. These methods are called *isogeometric*, and have received a lot of attention recently. This naturally implies to have access to CAD models of the geometry. On the other hand, *isoparametric* usually rely on a polynomial approximation of both the boundary and the solution. This can be added fairly easily on top of existing implementations. In the present study we focus on the latter type of method, since our goal is first to envisage the benefit of curvilinear meshes for light/matter interaction with nanoscale structures.

6.1.3. Numerical treatment of non-local dispersion for nanoplasmonics

Participants: Stéphane Lanteri, Claire Scheid, Nikolai Schmitt, Jonathan Viquerat.

When metallic nanostructures have sub-wavelength sizes and the illuminating frequencies are in the regime of metal's plasma frequency, electron interaction with the exciting fields have to be taken into account. Due to these interactions, plasmonic surface waves can be excited and cause extreme local field enhancements (surface plasmon polariton electromagnetic waves). Exploiting such field enhancements in applications of interest requires a detailed knowledge about the occurring fields which can generally not be obtained analytically. For the numerical modeling of light/matter interaction on the nanoscale, the choice of an appropriate model is a crucial point. Approaches that are adopted in a first instance are based on local (no interaction between electrons) dispersive models e.g. Drude or Drude-Lorentz. From the mathematical point of view, these models lead to an additional ordinary differential equation in time that is coupled to Maxwell's equations. When it comes to very small structures in a regime of 2 nm to 25 nm, non-local effects due to electron collisions have to be taken into account. Non-locality leads to additional, in general non-linear, partial differential equations and is significantly more difficult to treat, though. In this work, we study a DGTD method able to solve the system of Maxwell equations coupled to a linearized non-local dispersion model relevant to nanoplasmonics. While the method is presented in the general 3d case, in this preliminary study, numerical results are given for 2d simulation settings.

6.1.4. Multiscale DG methods for the time-domain Maxwell equations

Participants: Stéphane Lanteri, Raphaël Léger, Diego Paredes Concha [LNCC, Petropolis, Brazil], Claire Scheid, Frédéric Valentin [LNCC, Petropolis, Brazil].

Although the DGTD method has already been successfully applied to complex electromagnetic wave propagation problems, its accuracy may seriously deteriorate on coarse meshes when the solution presents multiscale or high contrast features. In other physical contexts, such an issue has led to the concept of multiscale basis functions as a way to overcome such a drawback and allow numerical methods to be accurate on coarse meshes. The present work, which has been initiated in the context of the visit of Frédéric Valentin in the team, is concerned with the study of a particular family of multiscale methods, named Multiscale Hybrid-Mixed (MHM) methods. Initially proposed for fluid flow problems, MHM methods are a consequence of a hybridization procedure which characterizes the unknowns as a direct sum of a coarse (global) solution and the solutions to (local) problems with Neumann boundary conditions driven by the purposely introduced hybrid (dual) variable. As a result, the MHM method becomes a strategy that naturally incorporates multiple scales while providing solutions with high order accuracy for the primal and dual variables. The completely independent local problems are embedded in the upscaling procedure, and computational approximations may be naturally obtained in a parallel computing environment. In this study, a family of MHM methods is proposed for the solution of the time-domain Maxwell equations where the local problems are discretized either with a continuous FE method or a DG method (that can be viewed as a multiscale DGTD method). Preliminary results have been obtained in the 2d case for model problems.

6.1.5. HDG methods for the time-domain Maxwell equations

Participants: Alexandra Christophe-Argenvillier, Stéphane Descombes, Stéphane Lanteri.

This study is concerned with the development of accurate and efficient solution strategies for the system of 3d time-domain Maxwell equations coupled to local dispersion models (e.g. Debye, Drude or Drude-Lorentz models) in the presence of locally refined meshes. Such meshes impose a constraint on the allowable time step for explicit time integration schemes that can be very restrictive for the simulation of 3d problems. We consider here the possibility of using an unconditionally stable implicit time integration scheme combined to a HDG discretization method. As a first step, we extend our former study in [20] which was dealing with the 2d time-domain Maxwell equations for non-dispersive media.

6.1.6. HDG methods for the frequency-domain Maxwell equations

Participants: Stéphane Lanteri, Liang Li [UESTC, Chengdu, China], Ludovic Moya, Ronan Perrussel [Laplace Laboratory, Toulouse].

In the context of the ANR TECSER project, we continue our efforts towards the development of scalable high order HDG methods for the solution of the system of 3d frequency-domain Maxwell equations. We aim at fully exploiting the flexibility of the HDG discretization framework with regards to the adaptation of the interpolation order (p -adaptivity) and the mesh (h -adaptivity). In particular, we study the formulation of HDG methods on a locally refined non-conforming tetrahedral mesh and on a non-conforming hybrid cubic/tetrahedral mesh. We also investigate the coupling between the HDG formulation and a BEM (Boundary Element Method) discretization of an integral representation of the electromagnetic field in the case of propagation problems theoretically defined in unbounded domains.

6.2. Elastodynamic wave propagation

6.2.1. Seismic wave interaction with viscoelastic media

Participants: Nathalie Glinsky, Stéphane Lanteri, Fabien Peyrusse [Department of Mathematics, Purdue University].

This work is concerned with the development of high order DGTD methods formulated on unstructured simplicial meshes for the numerical solution of the system of time-domain elastodynamic equations. These methods share some ingredients of the DGTD methods developed by the team for the time-domain Maxwell equations among which, the use of nodal polynomial (Lagrange type) basis functions, a second order leap-frog time integration scheme and a centered scheme for the evaluation of the numerical flux at the interface between neighboring elements. A recent novel contribution is the numerical treatment of viscoelastic attenuation. For this, the velocity-stress first order hyperbolic system is completed by additional equations for the anelastic functions including the strain history of the material. These additional equations result from the rheological model of the generalized Maxwell body and permit the incorporation of realistic attenuation properties of viscoelastic material accounting for the behaviour of elastic solids and viscous fluids. In practice, we need solving $3L$ additional equations in 2d (and $6L$ in 3d), where L is the number of relaxation mechanisms of the generalized Maxwell body. This method has been implemented in 2d and 3d.

6.2.2. DG method for arbitrary heterogeneous media

Participants: Nathalie Glinsky, Diego Mercerat [CETE Méditerranée].

We have recently devised an extension of the DGTD method for elastic wave propagation in arbitrary heterogeneous media. In realistic geological media (sedimentary basins for example), one has to include strong variations in the material properties. Then, the classical hypothesis that these properties are constant within each element of the mesh can be a severe limitation of the method, since we need to discretize the medium with very fine meshes resulting in very small time steps. For these reasons, we propose an improvement of the DGTD method allowing non-constant material properties within the mesh elements. A change of variables on the stress components allows writing the elastodynamic system in a pseudo-conservative form. Then, the introduction of non-constant material properties inside an element is simply treated by the calculation, via convenient quadrature formulae, of a modified local mass matrix depending on these properties. This new extension has been validated for a smoothly varying medium or a strong jump between two media, which can be accurately approximated by the method, independently of the mesh.

6.2.3. HDG method for the frequency-domain elastodynamic equations

Participants: Hélène Barucq [MAGIQUE-3D project-team, Inria Bordeaux - Sud-Ouest], Marie Bonnasse-Gahot, Julien Diaz [MAGIQUE-3D project-team, Inria Bordeaux - Sud-Ouest], Stéphane Lanteri.

One of the most used seismic imaging methods is the full waveform inversion (FWI) method which is an iterative procedure whose algorithm is the following. Starting from an initial velocity model, (1) compute the solution of the wave equation for the N sources of the seismic acquisition campaign, (2) evaluate, for each source, a residual defined as the difference between the wavefields recorded at receivers on the top of the subsurface during the acquisition campaign and the numerical wavefields, (3) compute the solution of the wave equation using the residuals as sources, and (4) update the velocity model by cross correlation of images produced at steps (1) and (3). Steps (1)-(4) are repeated until convergence of the velocity model is achieved. We then have to solve $2N$ wave equations at each iteration. The number of sources, N , is usually large (about 1000) and the efficiency of the inverse solver is thus directly related to the efficiency of the numerical method used to solve the wave equation. Seismic imaging can be performed in the time-domain or in the frequency-domain regime. In this work which is conducted in the framework of the Depth Imaging Partnership (DIP) between Inria and TOTAL, we adopt the second setting. The main difficulty with frequency-domain inversion lies in the solution of large sparse linear systems which is a challenging task for realistic 3d elastic media, even with the progress of high performance computing. In this context, we study novel high order HDG methods formulated on unstructured meshes for the solution of the frequency-domain elastodynamic equations. Instead of solving a linear system involving the degrees of freedom of all volumic cells of the mesh, the principle of a HDG formulation is to introduce a new unknown in the form of Lagrange multiplier representing the trace of the numerical solution on each face of the mesh. As a result, a HDG formulation yields a global linear system in terms of the new (surfacic) unknown while the volumic solution is recovered thanks to a local computation on each element.

6.2.4. Multiscale DG methods for the time-domain elastodynamic equations

Participants: Marie-Hélène Lallemand Tenkès, Frédéric Valentin [LNCC, Petropolis, Brazil].

In the context of the visit of Frédéric Valentin in the team, we have initiated a study aiming at the design of novel multiscale methods for the solution of the time-domain elastodynamic equations, in the spirit of MHM (Multiscale Hybrid-Mixed) methods previously proposed for fluid flow problems. Motivation in that direction naturally came when dealing with non homogeneous anisotropic elastic media as those encountered in geodynamics related applications, since multiple scales are naturally present when high contrast elasticity parameters define the propagation medium. Instead of solving the usual system expressed in terms of displacement or displacement velocity, and stress tensor variables, a hybrid mixed-form is derived in which an additional variable, the Lagrange multiplier, is sought as representing the (opposite) of the surface tension defined at each face of the elements of a given discretization mesh. We consider the velocity/stress formulation of the elastodynamic equations, and study a MHM method defined for a heterogeneous medium where each elastic material is considered as isotropic to begin with. If the source term (the applied given force on the medium) is time independent, and if we are given a arbitrarily coarse conforming mesh (triangulation in 2d, tetrahedrization in 3d), the proposed MHM method consists in first solving a series of fully decoupled (therefore parallelizable) local (element-wise) problems defining parts of the full solution variables which are directly related to the source term, followed by the solution of a global (coarse) problem, which yields the degrees of freedom of both the Lagrange multiplier dependent part of the full solution variables and the Lagrange multiplier itself. Finally, the updating of the full solution variables is obtained by adding each splitted solution variables, before going on the next time step of a leap-frog time integration scheme. Theoretical analysis and implementation of this MHM method where the local problems are discretized with a DG method, are underway.

NANO-D Project-Team

5. New Results

5.1. Variance Analysis of ARPS-Langevin dynamics

Participants: Zofia Trstanova, Gabriel Stoltz, Stephane Redon.

In order to analyze statistical convergence speed-up that can be achieved by using Adaptively Restrained Particle Simulations (ARPS) dynamics, we proposed a formula that combines the variance of the sampled process and the algorithmic speed-up:

$$S_\sigma = S_A \frac{\sigma_0^2}{\sigma_\epsilon^2} \quad (1)$$

where S_σ is the convergence speed-up, S_A is the algorithmic speed-up, σ_0^2 is the variance of the original system and σ_ϵ^2 is the variance of the ARPS-Langevin system. This led to a need of a detailed analysis of the variance of ARPS-Langevin process. We performed many numerical simulations, from the simple one-dimensional case up to more realistic dimer-solvent models, in order to observe the behavior of the variance and the quantitative dependence on the ARPS coefficients. For the one-dimensional case we managed to compute by using Galerkin approximations the numerical approximation of the variance. We are also studying analytically by use of standard techniques the properties of the ARPS-Langevin dynamics such as the existence of an invariant measure. We are also interested in the relationship between the variance of the Langevin dynamics and the ARPS-Langevin dynamics. We showed that for small ARPS coefficients the ARPS-Langevin process can be seen as a perturbation of a standard Langevin process by a perturbation operator that depends on the ARPS coefficient ϵ .

5.2. Parallel adaptively restrained particle simulations

Participants: Krishna Kant Singh, Stephane Redon.

We have continued our work on the development of *parallel* adaptively restrained particle simulations. We have integrated the ARPS algorithm in LAMMPS (Large-scale Atomic/ Molecular Massively Parallel Simulator). LAMMPS is a computationally efficient simulator, which contains a wide range of potentials and force fields for simulating systems like solid-state materials (metals, semiconductors), soft matter (biomolecules, polymers) and coarse-grained or mesoscopic systems.

In order to verify our implementation of ARPS in LAMMPS, we have generated a trajectory of 1 ns by simulating 108 Argon particles using the ARPS algorithm and the NVE ensemble (constant Number of particles, Volume and Energy). All the particles were placed in an orthogonal box with a side length of 17.158 angstrom. We used periodic boundary conditions with 8.5 angstrom cut-off for the Lennard-Jones potential. We used a threshold $\epsilon_r = 0.0000001$ for applying restraints and a threshold $\epsilon_f = 0.005$ for releasing restraints. The system was simulated at different step sizes: using 0.5, 1, 2, 3, 4, 5, 10, 50, 60, 70, 80 and 90 femtoseconds.

Our results show that ARPS in LAMMPS preserves the total energy during simulation (Figure 4) as well as the radial distribution function (Figure 5). We are now in the process of modifying the parallel force calculation algorithms in LAMMPS to make them incremental, i.e. make their cost proportional to the number of active particles in the simulation at a given time.

5.3. Molecular Modeling

5.3.1. The CARBON method

Participants: Sergei Grudin, Stephane Redon, Petr Popov.

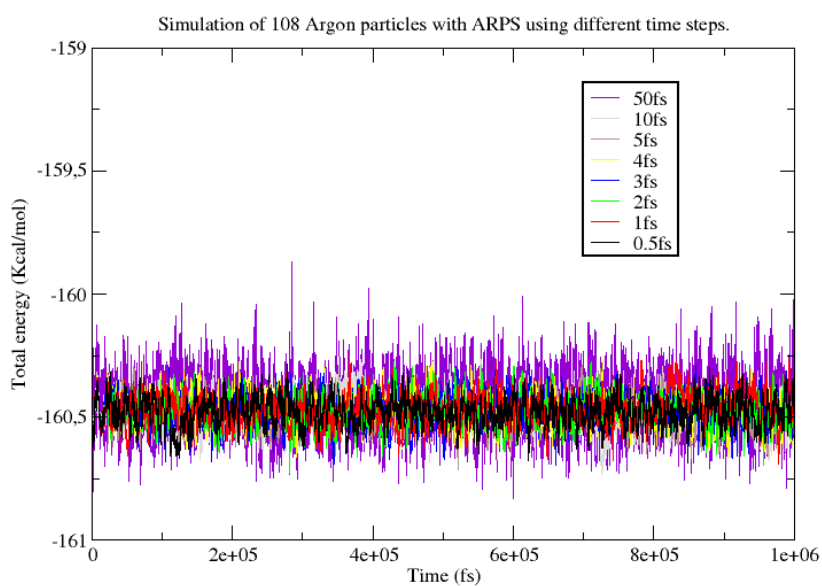

Figure 4. Energy conservation in LAMMPS using ARPS.

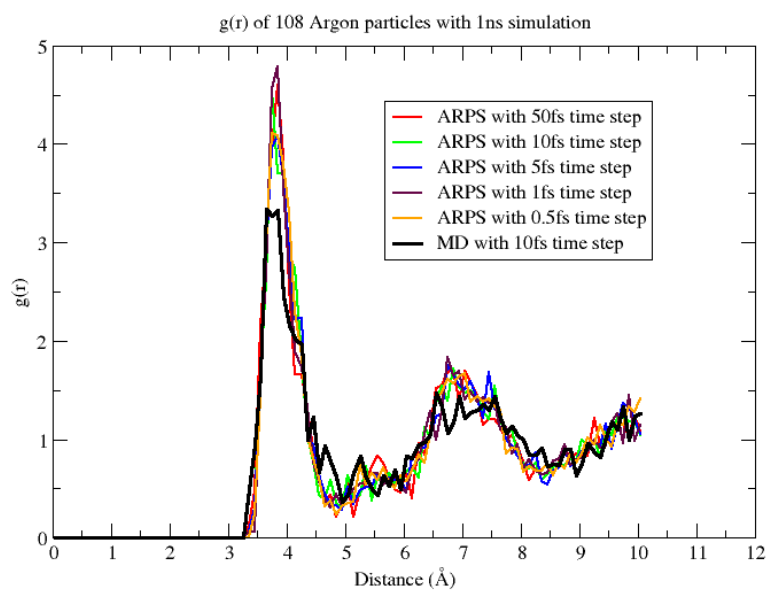

Figure 5. Preservation of the radial distribution function in LAMMPS using ARPS.

In molecular docking, various refinement algorithms are implied either to take into account flexibility of molecular complexes or to get rid of the docking artefacts, e.g. steric clashes. To address the latter problem, one possibility is to continuously minimize the energy of the complex with respect to the affine transformations, i.e. rigid transformations. Petr Popov developed a fast and efficient method called CARBON, where one considers the rigid-body optimization problem as the calculation of quasi-static trajectories of rigid bodies influenced by the inverse-inertia-weighted energy gradient. In order to determine the appropriate step-size in the direction of the net generalized force, we introduce the concept of advancement region, which is the interval of step-sizes that provide movements of the rigid body within a certain range of root mean square deviation from the initial conformation. We tested and validated CARBON on several benchmarks using both a classical force-field and a knowledge-based scoring function and demonstrated that CARBON significantly improves the quality of docking predictions and also remains stable when monomers of a molecular complex significantly overlap. CARBON will be made available as a SAMSON Element for the SAMSON software platform at <http://www.samson-connect.net>.

5.3.2. *The KSENIA method*

Participants: Petr Popov, Sergei Grudinin.

Molecular docking as an integral part of the drug discovery involves the scoring stage, where one selects the best binding candidates from the set of ligand poses. The scoring stage incorporates sophisticated scoring functions based on the empirical force-fields or the information derived from known structures of protein complexes. The latter type of scoring functions belongs to the family of the knowledge-based or statistical scoring functions. Typically, for the training of a knowledge-based scoring function, modern methods require an ensemble of generated non-native decoy structures and a computation of the reference state, which is challenging. Petr Popov developed a method that does not require neither the computation of the reference state nor the ensemble of non-native complexes. Furthermore, the developed approach fully relies on the structures of protein complexes in their native configurations. More precisely, Petr trained the knowledge-based scoring function based on sets of near-native conformations. These are composed using the fluctuations along the direction of low-frequency normal modes computed at the native configurations. The obtained scoring function is capable to distinguish the native and near-native protein-protein interactions from the non-native ones. The robustness of the method was verified on several protein-protein docking benchmarks. Our methodology can be easily adapted to the recognition of other types of molecular interactions, such as protein-ligand, protein-RNA, etc. KSENIA will be made publicly available as a part of the SAMSON software platform at <http://www.samson-connect.net>.

5.3.3. *Optimization solvers*

Participants: Petr Popov, Anatoli Juditsky, Sergei Grudinin.

To derive a knowledge-based scoring function, we map non-native and near-native molecular complexes to the vectors of descriptors in a high-dimensional space. In this space, we formulate an optimization problem to construct the scoring function in such a way, that the projection of a descriptor vector onto the scoring vector corresponds to the score of a molecular complex. The formulated problem contains the regularization term and the penalty term and might vary depending on the method applied to solve the optimization problem. Different methods provide different convergence rates and cost per operation. We implemented several modern first- and second-order optimization techniques and explored which one works the best on the given data. Namely, we tested the standard gradient descent method, the conjugate gradients method, the Nesterov method, the Fista and Fista-descent methods, and the proximal gradient method.

5.3.4. *Novel Docking Criterion*

Participants: Petr Popov, Sergei Grudinin.

Generally, to assess the prediction capabilities of a scoring function for protein- protein interactions, one evaluates the success rate of the scoring function on widely used protein-protein benchmarks. The percentage of correctly predicted complexes is taken as the characteristic of the scoring function. However, all existing benchmarks nowadays consists on many non-native and only few near- native conformations. However, the ability of the scoring function to distinguish a particular near-native conformation from the non-native decoys does not guarantee that the scoring function is able to distinguish another near-native conformation. The same is applied if the scoring function fails on a particular molecular complex. Thus, the success rate is not a robust criterion, since it depends on the near-native and non-native conformations presented in the benchmark. We proposed the new robust method to evaluate the predictive capability of a scoring function, which does not suffer from such drawback. The method uses the probability density function of the score computed from the set of the near-native conformations and complementary empirical distribution function of the score computed from the set on non-native conformations. We tested the criterion on the previously derived scoring functions and showed that the criterion also provides an insight on some limits and restrictions of the atom-atom distant-dependent knowledge-based scoring functions.

5.4. Flexible molecular fitting

Participants: Alexandre Hoffmann, Sergei Grudinin.

We have started a PhD on flexible molecular fitting. The first part of the PhD aims at developing a new method for non-rigid molecular fitting. The problem is the following : We have two proteins \mathcal{P}_1 and \mathcal{P}_2 and we know $d_1 : \mathbb{R}^3 \rightarrow \mathbb{R}$, the electron density of \mathcal{P}_1 and $(Y_k)_{k=0 \dots N_{atoms}-1}$, the average positions of the atoms of \mathcal{P}_2 . Assuming we can generate an artificial electron density $d_2 : \mathbb{R}^3 \rightarrow \mathbb{R}$ from $(Y_k)_{k=0 \dots N_{atoms}-1}$, our problem is to find a transformation of the atoms $T : \mathbb{R}^3 \rightarrow \mathbb{R}^3$ that minimizes the L^2 distance between d_1 and d_2 .

In image processing this problem is usually solved using the optimal transport theory, but this method assumes that both densities have the same L^2 norm, which is not necessarily the case for the fitting problem. To solve this problem, one instead starts by splitting T into a rigid transformation T_{rigid} (which is a combination of translation and rotation) and a flexible transformation $T_{flexible}$. Two classes of methods have been developed to find T_{rigid} :

- the first one uses optimization techniques such as gradient descent, and
- the second one uses Fast Fourier Transform (FFT) to compute the Cross Correlation Function (CCF) of d_1 and d_2 .

We have already developed several algorithms based on the FFT to find T_{rigid} and we now want to develop an efficient algorithm to find $T_{flexible}$.

The majority of algorithms first finds the best T_{rigid} and then use Normal Mode Analysis (NMA) to improve their fitting, the problem with such a method is that one can miss the optimal solution. We aim at developing a method that uses convex optimization to find the best $T_{flexible}$ for each T_{rigid} sampled on a grid, and therefore find the best T possible on a grid.

The rest of the PhD will be focused on the improvement of the modeling of the atom's motion, by using machine learning algorithms and methods that go beyond linear NMA. We hope that such an improvement can improve the quality of the fitting method.

5.5. PEPSI-Dock : Fast predictions of putative docking poses using accurate knowledge-based potentials functions to describe interaction between proteins

Participants: Emilie Neveu, Sergei Grudinin, David Ritchie, Petr Popov.

Many biological tasks involve finding proteins that can act as an inhibitor for a virus or a bacteria, for example. Such task requires knowledge on the structure of the complex to be formed. Protein Data Bank can help but only a small fraction of its proteins are complexes [16]. Therefore, computational docking predictions, being low-cost and easy to perform, are very attractive if they describe accurately the interactions between proteins while being fast to find which conformation will be the most probable. We have been developing a fast and accurate algorithm that combines the FFT-accelerated docking methods with the precise knowledge-based potential functions describing interactions between the atoms in the proteins.

Docking methods can be described as a two ingredients recipe. First, a certain approximation for the binding free energy needed to describe the interactions between the proteins. Second, an efficient sampling algorithm is used to find the lowest-energy conformations. Commonly, as going through all the possibilities with a realistic energy function is very costly, it is approximated with a very simple energy function. Then, a much more precise energy function is typically used to re-score the most promising predictions. Considering the numerous local minima that can be found, it is important to use the most accurate free energy from the beginning not to miss some important docking solutions. In the *Hex* code, an exhaustive search combined with a spherical polar Fourier representation enables the fast exploration of all the conformations. By now it is still the most efficient and reliable search algorithm [21]. However, only a few types of energies have been accelerated using this technic (shape complementarity and electrostatics, for example). Knowledge-based potential functions are much more precise but have been used only at the re-scoring stage of the protein docking predictions pipeline. Thus, our aim is to take advantage of the fast exhaustive search by integrating the very-detailed knowledge-based potentials into the *Hex* exhaustive search method.

We have demonstrated that we can adapt the machine learning process so that the knowledge-based potentials describing atom interactions can be translated into the polynomial basis used in *Hex*. Then, the knowledge-based scores are calculated in *Hex* using the fast polynomial expansions accelerated by the fast Fourier transform. The current evaluations of the knowledge-based scores takes more time than a shape+electrostatic representation but is still fast. More precisely, docking predictions for a single complex takes on average 5-10 minutes on a regular laptop computer. The preliminary results on the data set used for training shows significant improvements in accuracy of the method. Indeed, considering the prediction is correct if its Root Mean Square distance from the true solution is smaller than 5 Å, we currently obtain more than 50% of correct predictions rank first.

5.6. Extended Universal Force Field

Participants: Svetlana Artemova, Leonard Jaillet, Stephane Redon.

In parallel with the implementation of a Universal Force Field module in SAMSON (see Section 5.10.3), we have developed an extension of this force field to allow soft transitions for both topologies and atoms' typizations. In classical UFF topologies and atoms' typizations are set in the initialization phase and remain fixed for the entire simulation. In the proposed extension, they can vary continuously to allow the transition from one given topology to another (see Figure 6). This extended UFF combined with the interaction modeling tools already present in SAMSON allows to interactively build and modify molecules while being driven by UFF forces to ensure the relevance of the corresponding structures. The validity of this extended version of UFF was also tested on the same type of benchmarks as those used to test UFF.

5.7. Incremental Algorithms for Orbital-Free Density Functional Theory

Participants: François Rousse, Stephane Redon.

We have started a new PhD to develop incremental algorithms for electronic structure calculation.

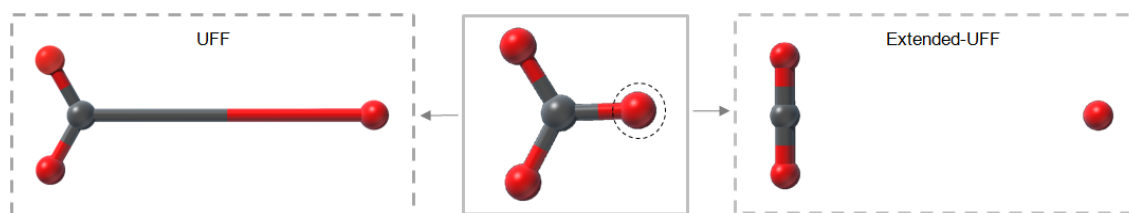

Figure 6. An oxygen atom (dashed circle) of the carbonate ion CO_3^{2-} is displaced using the interactive simulation framework in SAMSON (center). With standard UFF, the topology remains unchanged which leads to unrealistic geometries (left). With extended UFF, the covalent bond is broken forming a Carbon dioxide CO_2 and an isolated Oxygen (right).

Density Functional Theory (DFT) permits to simulate the electronic structure of a molecular system without solving the Schrödinger equation, but by finding incrementally the electronic density that minimizes the system's energy. The most used method is based on the determination of molecular orbitals. It has been shown to be an accurate method but the computation of the energy makes it too slow for the study of big systems ($> 10^3$ atoms) or dynamical ones. The Orbital-Free DFT, although less precise, is faster and can simulate the electronic density of systems up to 10^6 atoms. The aim of the PhD research is to develop new algorithms for Orbital-Free DFT that are *incremental*, i.e. whose complexity depends on the atoms that are adaptively simulated.

5.8. Robotics-inspired methods for large nanosystems

Participants: Minh Khoa Nguyen, Leonard Jaillet, Stephane Redon.

We have started a new PhD to develop robotics-inspired methods for modeling and simulating large nanosystems. Several motion planning methods issued from robotics have been successfully applied to solve problems in the field of biological molecular systems such as, including probabilistic roadmap and rapidly-exploring random trees [12]. However, large systems are still challenging due to the high number of degree of freedom. Our aim is to apply dimensionality reduction methods and/or smart conformational-space exploration techniques inspired from robotics to overcome this difficulty. The PhD topic has started since 1 Oct 2014. Reviews of the state of art and preliminary implementations have been done.

5.9. Incremental algorithms for long-range interactions

Participants: Semeho Edoth, Stephane Redon.

We have started a PhD to develop incremental algorithms for calculating long-range molecular interactions. Numerical simulation of molecular dynamics are very expensive in terms of CPU resources, especially because of the evaluation of the interaction potential. In large crystalline ionic systems, *Ewald summation* is the most popular method for computing Coulombic interactions. It rewrites the interaction potential ϕ as the sum of two terms: $\phi(r) = \phi_{dir}(r) + \phi_{rec}(r)$. The so-called “short-range” contribution ϕ_{dir} can be easily calculated in a direct space, where as the “long-range” contribution ϕ_{rec} is calculated using a Fourier transform.

Direct evaluation of the Ewald summation is an order N^2 computational problem. Over the past three decades, many techniques were developed and reduced the evaluation of the potential to an order $N \log(N)$ problem. We want to develop a new approach that can reduce the computational cost by using incremental algorithms. The key idea is to use, at each time step of the simulation, information that has been computed in previous steps.

5.10. Software development of SAMSON

5.10.1. Development of SAMSON Connect

Participants: Mohamed Yengui, Jocelyn Gate, Stephane Redon.

We have continued the development of SAMSON Connect, the web site that will contribute to the diffusion and promotion of SAMSON and SAMSON Elements (modules for SAMSON).

SAMSON Elements are adapted to different application domain and help users build new models, perform calculations, run interactive or offline simulations, visualize and interpret results, etc. The goal of SAMSON Connect is to bring together a set of users and developers of SAMSON Elements in all areas of nanoscience (physics, biology, chemistry, electronics, etc...). It offers a set of features available depending on the user role:

- Developers (who have obtained the SAMSON-SDK) can develop SAMSON Elements and upload them to SAMSON Connect through the tools provided.
- Users (who have obtained the SAMSON Core application) can add SAMSON Elements to their instance of SAMSON Core in one click. The download process is performed during startup of SAMSON and without outside intervention.

All users can give feedbacks, review and rate SAMSON Elements after adding them to their SAMSON Core (Figure 7).

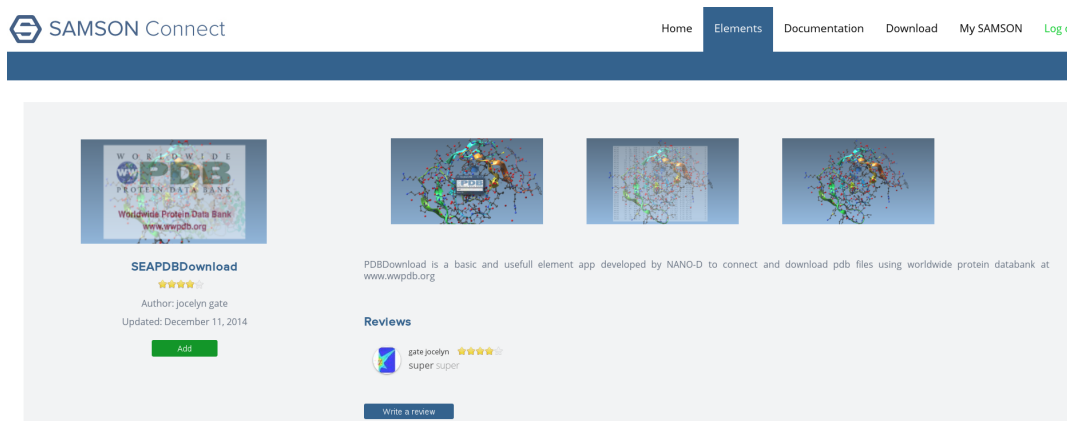

Figure 7. Screenshot of a SAMSON Element on SAMSON Connect.

SAMSON Connect also features some documentation to develop new elements for SAMSON (Figure 8).

SAMSON Connect will be available at <http://samson-connect.net>.

5.10.2. Deployment of SAMSON and the SAMSON SDK

Participants: Jocelyn Gate, Mohamed Yengui, Stephane Redon.

The SAMSON installer has been split in two parts: SAMSON-setup (installation of the SAMSON application, Figure 9) and SAMSON-Developer-setup (installation of the SAMSON SDK). internet. It is very useful to increase security.

Several helper tools related to SAMSON Elements management were developed to facilitate Element deployment. For example, the element packager is a tool useful for developers who want to distribute a new SAMSON Element on the SAMSON Connect platform. With this packager we can control many things: check whether the file is valid, if the SAMSON Element is readable with SAMSON, add a description file that contains useful information (name, author ID, checksum, element version, SDK version, operating system, etc.).

The screenshot shows the SAMSON Connect website. At the top left is the SAMSON Connect logo. To the right are navigation links: Home, Elements, and Documentation. Below this is a dark blue navigation bar with 'Users' and 'Developers' tabs. Underneath are sub-links: Main Page, Related Pages, Classes, and Files. The main content area is titled 'SAMSON's Software Development Kit' and is divided into sections: 'Getting Started' (with links to Installing SAMSON and its Software Development Kit, Quick Start, The Element Generator, and Tutorials), 'Fundamentals' (with an 'Overview' section listing SAMSON's architecture, SAMSON Documents, SAMSON Elements, and Adaptive Modeling and Simulation in SAMSON), 'Key mechanisms' (with links to Signals and slots, Editors, The referencing system, Rendering, and Units), 'Advanced topics' (with a link to Serialization), and 'Reference'.

Figure 8. Screenshot of documentation on SAMSON-Connect.

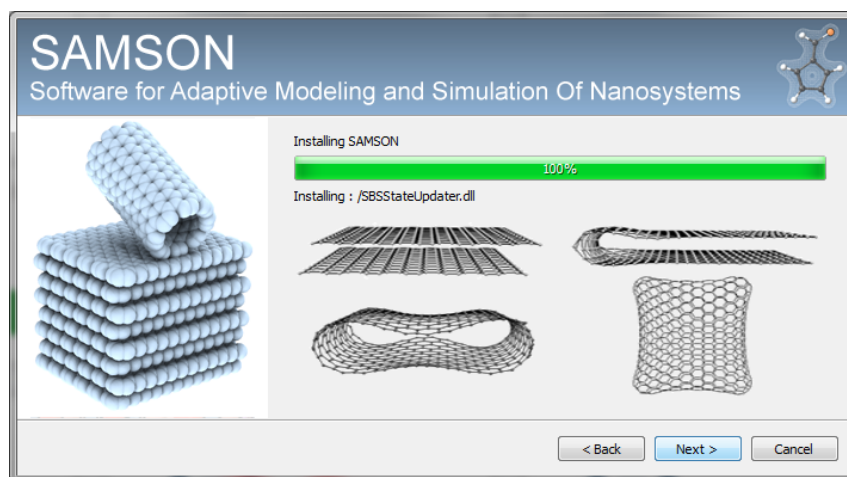

Figure 9. The SAMSON Installer

We added a service requester to SAMSON to communicate with SAMSON Connect and

- Check users/developers status
- Easily download new SAMSON Elements
- Be notified about updates

5.10.3. Universal Force Field

Participants: Svetlana Artemova, Leonard Jaillet, Stephane Redon.

We have implemented a version of the Universal Force Field (UFF) [19] in SAMSON, as a SAMSON Element embedding an interaction model. UFF is a classical force field, which can take as input almost every atom of the periodic table. Such flexibility allows to potentially use UFF on a large spectrum of systems and since its introduction, it has been applied to simulate problems involving main group compounds, organic molecules, metal complexes and has even been recently extended to MOF (Metal Organic Framework) [11]. The general energy expression for UFF as described in [19] is:

$$E_{UFF} = E_R + E_\theta + E_\phi + E_\omega + E_{vdw} + E_{el},$$

where E_R stands for bond stretching, E_θ describes angle bending, E_ϕ is dihedral angle torsion term, E_ω represents inversion, E_{vdw} stands for van der Waals interactions and E_{el} represents electrostatics (this last term is rarely considered for UFF, we do not study it neither). Forces involved in the atoms interactions can then be derived from the previous expression. Each energetic term in UFF can be computed based on simple rules deduced from a set of parameters. This set is based on the atoms' elements, their hybridization, and the overall connectivity of the molecular system.

In our implementation, we took into account several corrections and refinements that have been lately proposed in the literature for Universal Force Field. Our contribution also concerns the development of algorithms to automatically perceive the system's topology (covalent bonds and bond orders assignments). Moreover, we have introduced a method to automatically find the correct typization of the atoms. Precisely, atoms' hybridizations and oxidation states are computed, and resonance groups within or out of cycles are detected and treated. The implementation provided is computationally efficient enough to allow interactive simulation in SAMSON. The validity of the force field was tested on several groups of molecules proposed as benchmarks in the literature.

5.10.4. Integration of existing tools

Participants: Nadhir Abdellatif, Svetlana Artemova, Stephane Redon.

We have obtained funding from the Nanosciences Foundation in Grenoble to integrate in SAMSON some tools developed and used by the Grenoble community, in the form of SAMSON Elements, i.e. modules that integrate into SAMSON and may interact with SAMSON's main data graph. In particular, we have been meeting with some biologists and physicists to determine which tools and methods used (or developed) in Grenoble would be most appropriate for integration.

We integrated our first Element which is Babel, a chemical toolbox designed to "speak the many languages of chemical data", i.e. read, write and convert data files (over 110 chemical file formats) from molecular modeling, chemistry, solid-state materials, biochemistry, or related areas (see <http://openbabel.org>). The corresponding SAMSON element is an *app* that delegates all calculations to the Babel external executable. The app also makes it possible to import the data files to SAMSON to visualize the molecular data and proceed with other SAMSON elements.

We have also integrated Clustal, a tool for multiple sequence alignment. Thanks to Clustal's license, all source code is wrapped into the SAMSON Element (whose source code will be made available as well), and SAMSON users do not need to install Clustal separately.

5.10.5. Various

Participants: Stephane Redon, Svetlana Artemova, Marc Aubert.

- Units management was added to SAMSON. The mechanism relies on C++ template meta-programming techniques to perform dimensional analysis and automatic conversions at compile time, and has no runtime overhead. This was a significant undertaking, but one that will be very helpful to integrate in SAMSON different domains of nanoscience that have come to use different units for identical dimensions (e.g. kilocalories per mole in biology, electron volts in chemistry, etc.).
- SAMSON's reflection mechanism was improved to perform type registration and casting, and facilitate scripting and pipelining of SAMSON Elements.
- SAMSON now handles multiple documents.
- SAMSON has its own file format, which allows it to save the data graph information.
- More data graph nodes are now visible in SAMSON's data graph view.
- The split between classical and quantum interaction models was abandoned, for simplicity.
- SAMSON now handles multiple cameras.
- Selection methods have been improved, and selection is now undoable. Selections may be saved, retrieved, have boolean operations performed onto them, etc.
- The documentation of the SAMSON SDK has been improved.
- Controllers, a new type of data graph nodes, were added to SAMSON. Controllers are used to act on other data graph nodes (e.g. translate and rotate models).
- The object lifecycle of SAMSON was improved.
- SAMSON now has a mechanism for serialization.
- SAMSON now has preferences (e.g. for rendering).
- Existing parsers for input and output of molecular information in SAMSON have been improved and accelerated, and property windows for these parsers have been added.
- The Lennard-Jones potential has been added as an interaction model to SAMSON.
- A new editor for adding atoms corresponding to a chemical formula (in disorder) has been created.
- The work on a new editor containing functional groups and frequently-used molecular patterns has been started.
- Periodic Boundary Conditions (an important concept in molecular simulations) were implemented in SAMSON.
- General code debugging and improvement has been performed
- We decided to use the Qt5 framework for shaders management, for some maintenance reasons especially. This structure implied some other type changes to adapt to Qt5, such as the vertex buffers.
- We changed the way viewports display text. It is now possible to run SAMSON on every platform (Windows, Linux and Mac) and display text, and it provides Elements programmers a simple way to add text where they want in the 3D view.

OPALE Project-Team

6. New Results

6.1. Highlights of the Year

Paola Goatin was awarded the “*Prix Inria - Académie des sciences du jeune chercheur*”.

6.2. Mathematical analysis and control of macroscopic traffic flow models

6.2.1. Vehicular traffic

Participants: Enrico Bertino, Guillaume Costeseque, Maria Laura Delle Monache, Paola Goatin, Sheila Scialanga, Alexandre Bayen [UC Berkeley, CA, USA], Sebastien Blandin [IBM Research Collaboratory, Singapore], Christophe Chalons [LJLL, UP7].

In collaboration with UC Berkeley, and as part of the Associated Team ORESTE activity (see <http://www-sop.inria.fr/members/Paola.Goatin/ORESTE/index.html>), we have considered the System Optimal Dynamic Traffic Assignment problem with Partial Control (SO-DTA-PC) for general road networks with horizontal queuing. The goal of which is to optimally control any subset of the networks agents to minimize the total congestion of all agents in the network. We adopt a flow dynamics model that is a Godunov discretization of the Lighthill-Williams-Richards (LWR) partial differential equation with a triangular flux function and a corresponding multi-commodity junction solver. Full Lagrangian paths are assumed to be known for the controllable agents, while we only assume knowledge of the aggregate turn ratios for the non-controllable (selfish) agents. We solve the resulting finite horizon non-linear optimal control problem using the discrete adjoint method, see [75].

As part of our TRAM3 activity and in collaboration with C. Chalons (UVSQ), we designed a new finite volume conservative algorithm to track the trajectory of a bus in the surrounding traffic using a locally non-uniform moving mesh, see [70].

In collaboration with S. Blandin (IBM), we proved the existence and stability of entropy weak solutions of a scalar conservation law with non-local flux arising in traffic flow modeling. The result is obtained providing accurate L^∞ , BV and L^1 estimates for the sequence of approximate solutions constructed by an adapted Lax-Friedrichs scheme.

In collaboration with the University of Mannheim and in the framework of the PHC Procope project “Transport Networks Modeling and Analysis”, we studied how to manage variable speed limits combined with coordinated ramp metering within the framework of the LWR network model. Following a “first discretize then optimize” approach, we derived the first order optimality system and explained the switch of speeds at certain fixed points in time and the boundary control for the ramp metering as well. Sequential quadratic programming methods are used to solve the control problem numerically. For application purposes, we present experimental setups where variable speed limits are used as a traffic guidance system to avoid traffic jams on highway interchanges and on-ramps, see [71].

Finally, E. Bertino internship was devoted to uncertainty quantification in macroscopic traffic flow models.

6.2.2. Crowd motion

Participants: Aekta Aggarwal, Régis Duvigneau, Paola Goatin, Matthias Mimault, Rinaldo M. Colombo [Brescia University, Italy].

A. Aggarwal postdoc is devoted to the analytical and numerical study of systems of conservation laws with non-local fluxes in several space dimensions. In collaboration with R.M. Colombo, we presented a Lax-Friedrichs type algorithm to numerically integrate this class of systems. The convergence of the approximate solutions was proved, also providing the existence of solution in a slightly more general setting than in other results in the current literature. An application to a crowd dynamics model is considered. This numerical algorithm is then used to test the conjecture that as the convolution kernels converge to a Dirac δ , the nonlocal problem converges to its non-nonlocal analogue.

M. Mimault is working on scalar conservation laws with non-local flow in two space dimensions. These equations are meant to model crowd motion, where the movement direction of each pedestrian depends on a weighted mean of the crowd density around him. In particular, M. Mimault is implementing a finite volume numerical scheme which will be used for flow optimization purposes.

The above researches were partially funded by the ERC Starting Grant "TRAM3 - Traffic management by macroscopic models".

6.3. Optimum design and control in fluid dynamics and its couplings

In computational sciences for physics and engineering, Computational Fluid Dynamics (CFD) are playing one of the major roles in the scientific community to foster innovative developments of numerical methodologies. Very naturally, our expertise in compressible CFD has led us to give our research on numerical strategies for optimum design a particular, but not exclusive focus on fluids.

The framework of our research aims to contribute to numerical strategies for PDE-constrained multi-objective optimization, with a particular emphasis on CPU-demanding computational applications in which the different criteria to be minimized (or reduced) originate from different physical disciplines that share the same set of design variables. These disciplines are often fluids, as a primary focus, coupled with some other disciplines, such as structural mechanics.

Our approach to *competitive optimization* is focused on the two-discipline problem. It is based on a particular construction of *Nash games*, relying on a *split of territory* in the assignment of individual strategies. A methodology has been proposed for the treatment of two-discipline optimization problems in which one discipline, the primary discipline, is preponderant, or fragile. Then, it is recommended to identify, in a first step, the optimum of this discipline alone using the whole set of design variables. Then, an orthogonal basis is constructed based on the evaluation at convergence of the Hessian matrix of the primary criterion and constraint gradients. This basis is used to split the working design space into two supplementary subspaces to be assigned, in a second step, to two virtual players in competition in an adapted Nash game, devised to reduce a secondary criterion while causing the least degradation to the first. The formulation has been proved to potentially provide a set of Nash equilibrium solutions originating from the original single-discipline optimum point by smooth continuation, thus introducing competition gradually [65] (see also subsection:helico).

Our approach to *cooperative optimization*, in theory, is not limited in number of objective functions. It is based on a result of convex analysis established for a general unconstrained multiobjective problem in which all the gradients are assumed to be known. The theorem [66] states that in the convex hull of the gradients, there exists a unique vector of minimal norm, ω ; if it is nonzero, the vector ω is a descent direction common to all criteria; otherwise, the current design point is Pareto-stationary. This result led us to generalize the classical steepest-descent algorithm by using the vector ω as search direction. We refer to the new algorithm as the multiple-gradient descent algorithm (MGDA). The MGDA yields to a Pareto-stationary point, and in practice actual Pareto-optimality is verified a posteriori.

The two approaches have been combined to explore the Pareto front segment-wise as illustrated on Figure 2 .

6.3.1. Multiple-Gradient Descent Algorithm (MGDA)

Participants: Jean-Antoine Désidéri, Régis Duvigneau, Camilla Fiorini, Matteo Giacomini, Abderrahmane Habbal, Adrien Zerbinati.

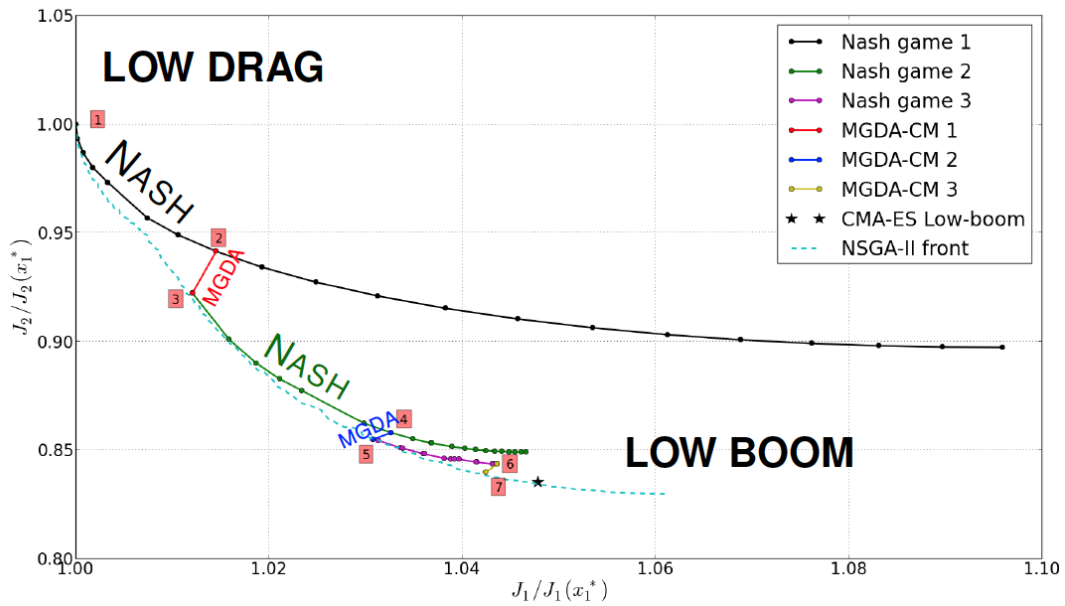

Figure 2. *Two-discipline optimization of a generic geometry of a supersonic aircraft, for concurrent drag and sonic-boom reduction* (from A. Minelli's doctoral thesis, 2013). The wave drag is calculated by the ONERA elsA code in 3D finite-volume Eulerian flow mode over a 6M-node mesh and the sonic boom using a three-layer approach. The Nash-game paths have been devised by appropriate territory splitting in order to be tangent to the Pareto front, and they are interrupted whenever the Pareto-stationarity condition is judged excessively violated. The MGDA paths converge rapidly back to the front. The simulation demonstrates how the two algorithms complement each other and provide a potential for a piecewise description of the Pareto front, evaluated more economically than a stochastic algorithm operating on a large population.

6.3.1.1. Theory and numerical experimentation of the MGDA construction

In multi-objective optimization, the knowledge of the Pareto set provides valuable information on the reachable optimal performance. A number of evolutionary strategies (PAES, NSGA-II, etc), have been proposed in the literature and proved to be successful to identify the Pareto set. However, these derivative-free algorithms are very demanding in terms of computational time. Today, in many areas of computational sciences, codes are developed that include the calculation of the gradient, cautiously validated and calibrated [66].

The notion of Pareto-stationarity, originally established to be a necessary condition of optimality in differentiable multi-objective optimization of unconstrained problems, has been extended to problems subject to equality constraints. On this basis, we were able to establish that by augmenting, in a classical manner, the objective-functions of a penalty term equal to the square of the constraint violation, and applying the standard MGDA to it, would result in converged solutions that are Pareto-stationary in the extended sense. Numerical experimentation on this is on-going.

6.3.1.2. Meta-model-assisted CFD optimization by MGDA

Using MGDA in a multi objective optimization problem requires the evaluation of a large number of points with regard to criteria, and their gradients. In the particular case of a CFD problems, each point evaluation is very costly since it involves a flow computation, possibly the solution of an adjoint-equation. To alleviate this difficulty, we have proposed to construct meta-models of the functionals of interest (lift, drag, etc) and to calculate approximate gradients by local finite differences. These meta-models are updated throughout the convergence process to the evaluation of the new design points by the high-fidelity model, here the 3D compressible Euler equations.

This variant of MGDA has been tested successfully over several aerodynamic shape optimization problems : lift concurrently with drag optimization for transonic aircraft; drag (under lift constraint) concurrently with sonic boom reduction for 3D supersonic configuration (at ONERA); drag (under lift constraint) concurrently with mass reduction for transport aircraft (at ONERA) [56].

6.3.1.3. Exact shape gradients

MGDA has successfully been tested over a two-objective optimization problem governed by two-dimensional elasticity. The deformation of a plate is calculated using an isogeometric approximation and compliance derived from it. The exact parametric shape gradient is calculated, yielding the gradient of the objective function in two antagonistic situations differing by the loading. Pareto-fronts are thus identified [68].

6.3.1.4. Optimization of an unsteady system using a multiobjective formulation

An approach has been developed to solve optimization problems in which the functional that has to be minimized is time dependent. In the literature, the most common approach when dealing with unsteady problems, is to consider a time-average criterion. However, this approach is limited since the dynamical nature of the state is neglected. Our alternative consists in building a set of cost functionals by evaluating a single criterion at different sampling times. In this way, the optimization of the unsteady system is formulated as a multi-objective optimization problem, solved using an appropriate descent algorithm (MGDA). Moreover, we also consider a hybrid approach in which the set of cost functionals is built by doing a time-average operation over multiple intervals. These strategies have been illustrated and applied to a non-linear unsteady system governed by a one-dimensional convection-diffusion-reaction partial differential equation [67].

6.3.1.5. Perspectives

MGDA offers the possibility to handle in a rational way several objective-functions for which gradients are known or approximated concurrently. This potential opens methodological paths to several themes of interest in high-fidelity simulation-based optimization: optimization of complex systems whose performance is evaluated w.r.t. several criteria originating from different, coupled disciplines; optimization under uncertainties, by introducing sensitivities as additional objectives; optimization of time-dependent systems, such as optimization of flow-control devices that generate a periodic flow (see next subsection), by converting the problem into a multipoint problem by time-discretization of the time and parameter-dependent functional (as above); etc.

6.3.2. Flow control

Participants: Régis Duvigneau, Jérémie Labroquère, Emmanuel Guilmineau [Ecole Centrale de Nantes].

Shape optimization methods are not efficient to improve the performance of fluid systems, when the flow is characterized by a strong unsteadiness related to a massive detachment. This is typically the case for the flow around an automotive body or a wing in stall condition. To overcome this difficulty, flow control strategies are developed, that aim at manipulating vortex dynamics by introducing some active actuators, such as periodic blowing/suction jets. In this context, the choice of the control parameters (location, amplitude, frequency) is critical and not straightforward. Therefore, we develop a methodology to determine optimal control parameters by coupling the simulation of unsteady actuated flows with optimization algorithms. Two research axes have been considered :

- the resolution of the unsteady sensitivity equations derived from the state equations, to exhibit the dependency of the flow dynamics with respect to the control and apply an unsteady gradient-based approach[67] ;
- the optimization of control parameters using a statistical metamodel-based strategy [39].

In this perspective, unsteady Reynolds Averaged Navier-Stokes equations are solved, with some turbulence closures. Different models for synthetic jet have been implemented to simulate the actuation, and then validated for different turbulence closures .

Specific developments have been carried out in the metamodel-based optimizer to include a noise term into Gaussian Process model, which is used to filter errors arising from unsteady simulations. A systematic assessment of modeling and numerical errors has been archived for a backward facing step test-case, with the objective of controlling the re-attachment point location[46], [58].

This activity is conducted in collaboration with the CFD team of Ecole Centrale de Nantes.

6.3.3. Adjoint-based mesh quality control

Participants: Jean-Antoine Desideri, Maxime Nguyen-Dinh [ONERA doctoral student], Jacques Peter [Research Engineer, ONERA/DSNA], Renaud Sauvage [Airbus France], Mathieu Meaux [EADS IW].

In his doctoral thesis [29], Nguyen Dinh has studied mesh adaptation methods based on the total derivatives of aerodynamic outputs with respect to mesh coordinates by the discrete adjoint method. Firstly, mesh adaptation methods have been devised for Eulerian flows. Zones to be refined are detected using a sensor based on the total derivative, and numerical experiments confirmed the adequacy of the approach. Secondly, the method was extended to the Reynolds-averaged Navier equations (RANS) and thirdly demonstrated for 3D industrial configurations [53].

6.3.4. Helicopter rotor blade optimization in both situations of hovering and forward flight

Participants: David Alfano [Airbus Helicopter], Michel Costes [Research Engineer, ONERA/DAAP], Jean-Antoine Désideri, Arnaud Le Pape [Research Engineer, ONERA/DAAP], Enric Roca Leon.

E. Roca Leon has conducted a CIFRE thesis at ONERA DAAP supported by Airbus Helicopter (Marignane) [34]. This thesis follows the doctoral thesis of A. Dumont in which the adjoint-equation approach was used to optimize a rotor blade in hovering flight. The goal of this new thesis is to solve a two-objective optimization problem in which the hovering-flight criterion is considered preponderant, but a new criterion that takes into account the forward-flight situation is also introduced, concurrently. The second criterion is the power necessary to maintain the forward motion. The first phase of thesis work has been devoted to the set up of a hierarchy of models from low to high fidelity, in order to calibrate appropriate functional criteria. Then, actual two-objective optimizations are conducted via our Nash game approach to competitive optimization with territory splitting based on reduced Hessian diagonalization. Successful optimization has been realized involving 16 geometrical parameters to reduce the power in forward motion while maintaining sub-optimality of the drag in hover [55] [64] [65].

6.4. Isogeometric analysis and design

Participants: Régis Duvigneau, Asma Gdhami, Bernard Mourrain [Galaad Project-Team], Bernd Simeon [Tech. Univ. of Kaiserslautern].

Design optimization stands at the crossroad of different scientific fields (and related software): Computer-Aided Design (CAD), Computational Fluid Dynamics (CFD) or Computational Structural Dynamics (CSM), parametric optimization. However, these different fields are usually not based on the same geometrical representations. CAD software relies on Splines or NURBS representations, CFD and CSM software uses grid-based geometric descriptions (structured or unstructured), optimization algorithms handle specific shape parameters. Therefore, in conventional approaches, several information transfers occur during the design phase, yielding approximations that can significantly deteriorate the overall efficiency of the design optimization procedure. Moreover, software coupling is often cumbersome in this context.

The isogeometric approach proposes to definitely overcome this difficulty by using CAD standards as a unique representation for all disciplines. The isogeometric analysis consists in developing methods that use NURBS representations for geometric modeling, computational domain description and solution basis functions. Using such a unique data structure allows to compute the solution on the exact geometry (not a discretized geometry), obtain a more accurate solution (high-order approximation), reduce spurious numerical sources of noise that deteriorate convergence, avoid data transfers between the software. Moreover, NURBS representations are naturally hierarchical and allows to define multi-level algorithms for solvers as well as optimizers.

In this context, a collaborative work has also been carried out with the Technical University of Kaiserslautern, concerning the computation of shape gradients for linear elasticity problems[42], [68]. Moreover, the doctoral thesis of Asma Gdhami, in collaboration with ENIT in Tunisia, has started and concerns the development of isogeometric schemes for hyperbolic systems.

6.5. Optimum design in structural mechanics

6.5.1. Shape Optimization in Multidisciplinary Non-Linear Mechanics

Participants: Aalae Benki, Jean-Antoine Désidéri, Abderrahmane Habbal, Gael Mathis [ArcelorMittal, CRAA].

In collaboration with the ArcelorMittal's Center for Research in Automotive and Applications (CRAA), we study the multidisciplinary shape and parameter design of highly non linear mechanical 2D and 3D structures. We have developed methods adapted to the approximation of Pareto Fronts such as Normal Boundary Intersection NBI and Normalized Normal Constraint Method NNCM. Due to the time consuming cost evaluation, the use of cheap to evaluate surrogate models is mandatory. We have studied the consistency of the approach NBI or NNCM plus surrogates, which turned out to be successful for a broad panel of standard mathematical benchmarks. The coupling is successfully applied to a small scale industrial case, namely the shape optimization of a can bottom vis à vis dome reversal pressure and dome growth criteria. We have then defined a Nash game between criteria where the latter are approximated by the RBF metamodels. First, we validated the computation of a Nash equilibrium for mathematical functions, then we computed Nash equilibria for the small scale industrial case of the shape optimization of the can bottom.

Then, we considered the 3D problem of an automotive twist beam. In this 3D case, we aim to Pareto-optimal shapes for two objectives, the first being to minimize the Von-Mises strain to guarantee the formability of the twist beam, and the second being to maximize the stiffness. For solution with higher stiffness than the initial one, we could decrease the thickness to obtain a mass reduction with the same end-user properties.

We also introduced, to our knowledge for the first time in the structural optimization area, the notion of Kalai-Smorodinky equilibria which is aimed at the selection of equilibria among Pareto-optimal solutions. We applied this notion of equilibria to both industrial cases, and compared the results to Nash equilibria.

6.5.2. Optimization of Addendum Surfaces in Stamping

Participants: Fatima Zahra Oujebbour, Rachid Ellaia, Abderrahmane Habbal, Ziheng Zhao.

Within the OASIS Consortium (ArcelorMittal, ErDF, Inria, UTC, EURODECISION, ESILV, NECS, DeltaCAD, SCILAB-DIGITEO), Opale Project leads the Optimization task. Our aim is to develop decentralized decision-making algorithms dedicated to find efficient solutions (Pareto optimal) in a complex multidisciplinary framework (forming, stamping, welding non-linear processes, spring-back, vibration, in-function linear processes, crash and fatigue non linear and non differentiable processes) for several (between three and five) criteria. An important difficulty when trying to identify the Pareto Front, even when using adapted methods such the Normal Boundary Intersection, is that the criteria involved (thanks to the high nonlinearity in the mechanical models) exhibit many local optima. So one must use global optimization methods. We have studied the hybrid approach Simulated Annealing with Simultaneous Perturbation SASP for a suite of mathematical test-cases. To envisage the application of our method to the complex CPU time consuming stamping process, we lead an intermediate phase dedicated to the validation of the SASP method for the minimization of the spring-back that follows the stamping of a metal sheet, the design variable being the process parameters (two then four parameters). Then, we considered the more complex shape design of the initial blank. The initial blank design is a critical step in stamping design procedure, therefore it should be optimally designed. Our aim is to find the optimal initial blank shape that avoids or at least minimizes the springback and failure flaws. For this study, the geometry of the blank contour is described by parametric spline curves. Seven control points (P1,...,P7) are used to define the spline curves in order to have a wide variety of geometries. The exact computational evaluation of our criteria, springback and failure, is very expensive (the FE model request around 45 min to predict these two criteria) and the design space is of quite high dimension. Therefore, we considered the recourse to the sparse grid interpolation. Optimization process based on sparse grid interpolation is an optimal alternative in which criteria can be approximated with a suitable interpolation formula that needs significantly less points than the full grid. The obtained metamodel using sparse grid interpolation needs less than 1s to predict springback and failure on the same computation machine. To find the optimal initial blank shape, it was decided to perform the optimization process using the obtained metamodel. The construction of the sparse grid interpolant was based on the Chebyshev Gauss-Lobatto grid type and using the polynomial basis functions. This technique achieves a good accuracy with a competitive number of grid points. The comparison of the obtained fronts shows that we can capture Pareto solutions by NBI and NNCM with fewer points than NSGAI which requires a large number of populations and several generations to obtain the Pareto front. [48] [49] [50]

6.6. Application of shape and topology design to biology and medicine

6.6.1. Assessing the ability of the 2D Fisher-KPP equation to model cell-sheet wound closure

Participants: Abderrahmane Habbal, Hélène Barelli [Univ. Nice Sophia Antipolis, CNRS, IPMC], Grégoire Malandain [Inria, EPI Morpheme].

We address in this joint collaboration the ability of the widely used Fisher-KPP equations to render some of the dynamical features of epithelial cell-sheets during wound closure.

Our approach is based on nonlinear parameter identification, in a two-dimensional setting, and using advanced 2D image processing of the video acquired sequences. As original contribution, we lead a detailed study of the profiles of the classically used cost functions, and we address the "wound constant speed" assumption, showing that it should be handled with care.

We study five MDCK cell monolayer assays in a reference, activated and inhibited migration conditions. Modulo the inherent variability of biological assays, we show that in the assay where migration is not exogenously activated or inhibited, the wound velocity is constant. The Fisher-KPP equation is able to accurately predict, until the final closure of the wound, the evolution of the wound area, the mean velocity of the cell front, and the time at which the closure occurred. We also show that for activated as well as for inhibited migration assays, many of the cell-sheet dynamics cannot be well captured by the Fisher-KPP model. Original unexplored utilizations of the model such as wound assays classification based on the calibrated diffusion and proliferation rate parameters is ongoing. [47]

6.7. Distributed Systems

6.7.1. *High-Performance manipulation and storage of e-Science data*

Participants: Benoit Lange, Toan Nguyen.

The work carried in previous years on distributed High-Performance Computing for e-Science workflows has enlightened the need for appropriate tools and methods to manage petabyte and exabyte volumes of data. This has been the focus of the work carried by Benoit Lange during his Post-Doc position in 2014. It was dedicated to the definition and prototyping of a large-scale HPC platform to support the execution of application solvers, efficient storage and management of large-volumes of data produced by the simulation applications and the visualization of their results on high-end graphics workstations. This platform also includes analytics software to produce specific results corresponding to the user queries. This is based on the Hadoop ecosystem [59]. It is central for the communication between the dedicated HPC nodes running the solvers and the visualization nodes interfacing the end-users. It includes high-speed storage with dedicated file systems on specific nodes, and long-term storage for reference data using magnetic juke-boxes that store petabytes of application data. This work is supported by an FP7 project in which Inria is responsible for the Data Management work-package (Call FP7-2013-ICT-11, Grant 619439, 2014-2016). The partners of the project, named VELA^{SSCo} (Visualization for Extremely Large Scale Scientific Computing), are : CIMNE (SP, coordinator), JOTNE and SINTEF (No), ATOS (SP), Fraunhofer IGD (D) and the University of Edinburg (UK).

POEMS Project-Team

6. New Results

6.1. Wave propagation in non classical media

6.1.1. *Plasmonic black-hole waves at corners of metals*

Participants: Anne-Sophie Bonnet-Ben Dhia, Camille Carvalho, Patrick Ciarlet.

This work, which is a part of the PhD of Camille Carvalho, is done in collaboration with Lucas Chesnel from CMAP at Ecole Polytechnique. We study the scattering of time-harmonic electromagnetic waves by a metallic obstacle in a 2D setting, at frequencies such that the dielectric permittivity of the metal has a negative real part and a small imaginary part. When the obstacle has corners, due to the sign-changing real part of the permittivity, unusual strong singularities for the electromagnetic field can appear. If the material dissipation is neglected, it can be necessary to consider a new functional framework, containing these singularities, to derive a well-posed problem. In this new framework, everything happens like if plasmonic waves were propagating to the corners, and a part of the energy is trapped by the corner, even if the material has been supposed non-dissipative. We have implemented an original numerical method consisting in using Perfectly Matched Layers at the corners to capture these black-hole waves. We have also proposed a new rule to mesh the corner in order to achieve convergence of classical finite elements in the simpler case where the problem is still well-posed in the classical framework. Finally, in collaboration with André Nicolet and Frédéric Zolla from Institut Fresnel in Marseille, we are now considering realistic dissipative metals. We show that there is still a significant effect of the black-hole phenomenon, which results in an unusual energy leakage in some frequency range.

6.1.2. *Limiting amplitude principle for a two-layered dielectric/metamaterial medium*

Participants: Maxence Cassier, Christophe Hazard, Patrick Joly.

This work has been a part of the PhD of Maxence Cassier and has allowed to initiate a collaboration with Boris Gralak from Institut Fresnel. For wave propagation phenomena, the limiting amplitude principle holds if the time-harmonic regime represents the large time asymptotic behavior of the solution of the evolution problem with a time-harmonic excitation. Considering a two-layered medium composed of a dielectric material and a Drude metamaterial separated by a plane interface, we prove that the limiting amplitude principle holds except for a critical situation related to a surface resonance phenomenon. Then the solution can either converge to the superposition of two time-periodic fields, or blow up linearly in time.

6.1.3. *Perfectly Matched Layers in plasmas and metamaterials*

Participants: Eliane Bécache, Patrick Joly, Maryna Kachanovska, Valentin Vinoles.

This work is a part of the PhD of Valentin Vinoles and is the subject of the post-doc of Maryna Kachanovska. It deals with the stability of Perfectly Matched Layers (PMLs) in dispersive media and is motivated by the fact that classical PMLs are unstable in negative index metamaterials and in some anisotropic plasmas. This led us to derive a new necessary criterion of stability which is valid for a large class of dispersive models and for more general PMLs than the classical ones. This criterion has been used to design new stable PMLs for negative index metamaterials and uniaxial anisotropic plasmas.

6.1.4. *Retrieval method for anisotropic metamaterials*

Participants: Aurore Castanié, Jean-François Mercier.

This work has been done during the post-doc of Aurore Castanié, in collaboration with Agnès Maurel from Institut Langevin at ESPCI and Simon Felix from the LAUM (Laboratoire d'Acoustique de l'Université du Maine). Electromagnetic or acoustic metamaterials can be described in terms of equivalent effective, in general anisotropic, media and several techniques exist to determine the effective permeability and permittivity (or effective mass density and bulk modulus in the context of acoustics). Among these techniques, retrieval methods use the measured scattering coefficients for waves incident on a metamaterial slab containing few unit cells. Until now, anisotropic effective slabs have been considered in the literature but they are limited to the case where one of the axes of anisotropy is aligned with the slab interface. We propose an extension to arbitrary orientations of the principal axes of anisotropy and oblique incidence. The retrieval method is illustrated in the electromagnetic case for layered media, and in the acoustic case for array of tilted elliptical particles.

6.2. Wave propagation in heterogeneous media

6.2.1. High order transmission conditions between homogeneous and homogenized periodic half-spaces

Participants: Sonia Fliss, Valentin Vinales.

This work is a part of the PhD of Valentin Vinales, and is done in collaboration with Xavier Claeys (LJLL, Paris VI). It is motivated by the fact that classical homogenization theory poorly takes into account interfaces, which is particularly unfortunate when considering negative materials, because important phenomena arise precisely at their surface (plasmonic waves for instance). To overcome this limitation, we want to construct high order transmission conditions. Using matched asymptotics, we have treated the case of a plane interface between a homogeneous and a homogenized periodic half space. The analysis is based on an original combination of Floquet-Bloch transform and a periodic version of Kondratiev techniques. The obtained conditions involve Laplace- Beltrami operators at the interface and requires to solve cell problems in infinite strips.

6.2.2. Multiple scattering by small homogeneities

Participants: Patrick Joly, Simon Marmorat.

This is the topic of the PhD of Simon Marmorat, done in collaboration with the CEA-LIST and with Xavier Claeys (LJLL, Paris VI). We aim at developing an efficient numerical approach to simulate the propagation of waves in concrete, which is modelled as a smooth background medium, with many small embedded heterogeneities. This kind of problem is very costly to handle with classical numerical methods, due the refined meshes needed around the inclusions. To overcome these issues, two models have been developed, which rely on the asymptotic analysis of the problem: each of them can be interpreted as a full space wave equation, which can be discretized using a defects-free mesh, coupled to some auxiliary unknowns accounting for the presence of the inclusions. While the first model is established by using a special Galerkin approximation in the vicinity of the inclusions, the second model only focuses on the far field. The challenge is then to simulate source points coupled to the incident field and this is achieved thanks to the introduction of a special relaxed version of the Dirac mass. Rigorous error estimates as well as some numerical tests have been established, highlighting the efficiency of the two methods.

6.2.3. Finite Element Heterogeneous Multiscale Method for Maxwell's Equations

Participants: Patrick Ciarlet, Sonia Fliss, Christian Stohrer.

This work is the subject of the post-doc of Christian Stohrer. The standard Finite Element Heterogeneous Multiscale Method (FE-HMM) can be used to approximate the effective behavior of solutions to the classical Helmholtz equation in highly oscillatory media. Using a novel combination of well-known results about FE-HMM and the notion of T-coercivity, we derive an a priori error bound. Numerical experiments corroborate the analytical findings. We work now on the application of HMM in presence of interfaces, for Maxwell's equations and finally in presence of high contrast materials.

6.2.4. *Effective boundary conditions for strongly heterogeneous thin layers*

Participants: Matthieu Chamaillard, Patrick Joly.

This topic is the object of the PhD of Matthieu Chamaillard, done in collaboration with Housseem Haddar (CMAP École Polytechnique). We are interested in the construction of effective boundary conditions for the diffraction of waves by an obstacle covered with a thin coating whose physical characteristics vary “periodically”. The width of the coating and the period are both proportional to the same small parameter δ . In the scalar case, we proved that the error between the exact model (with the thin coat) and the one with the effective boundary condition of order n for $n \in \{1, 2\}$ is of the order $\mathcal{O}(\delta^{n+1})$. This has been checked numerically for some two dimensional configurations. Recently, we also succeeded to extend our theoretical work to Maxwell equations. We found a first order boundary condition of the form $E \times n = \delta ik \mathcal{Z}_\Gamma (n \times (H \times n))$ where n is the unit outward normal to the boundary Γ and \mathcal{Z}_Γ is a second order tangential differential operator along Γ . The coefficients of this operator depend only on the deformation mapping ψ_Γ and the material properties of the coating, through the resolution of particular unbounded cell problems in the flat reference configuration. When the coating is homogeneous, one recovers the well known first order thin layer condition. We have moreover proven that this effective condition provides an error of the order $\mathcal{O}(\delta^2)$.

6.3. Spectral theory and modal approaches for waveguides

6.3.1. *Guided modes in ladder-like open periodic waveguides*

Participants: Sonia Fliss, Patrick Joly, Elizaveta Vasilevskaya.

This work is done in the context of the PhD of Elizaveta Vasilevskaya, in collaboration with Bérangère Delourme, from Paris 13 University. We consider the theoretical and numerical aspects of the wave propagation in ladder-like periodic structures. We exhibit situations where the introduction of a lineic defect into the geometry of the domain leads to the appearance of guided modes and we provide numerical simulations to illustrate the results. From the theoretical point of view, the problem is studied by asymptotic analysis methods, the small parameter being the thickness of the domain, so that when the thickness of the structure is small enough, the domain approaches a graph. Numerical computations are based on specific transparent conditions for periodic media.

6.3.2. *Absence of trapped modes for a class of unbounded propagative media*

Participants: Anne-Sophie Bonnet-Ben Dhia, Christophe Hazard, Sonia Fliss, Antoine Tonnoir.

We have proposed a new approach to prove that there does not exist square-integrable solutions to the two-dimensional Helmholtz equation in a homogeneous conical domain with a vertex angle greater than π . This shows that for a medium filling the whole plane, there can be no trapped modes if all the inhomogeneities (penetrable or not) are concentrated in a conical domain with a vertex angle less than π . The proof uses the compatibility of Fourier representations of the field in different half-spaces. One interesting consequence of our result concerns the case of curved open waveguides (e.g., bended optical fibers). Unlike closed waveguides for which trapped modes confined near the bend may occur, our result implies that trapped modes cannot exist if the core of the waveguide is located in a cone with vertex angle less than π . Our results can be extended to higher space dimensions, and to some Y-junctions of open waveguides (using a generalized Fourier transform instead of the usual one).

6.3.3. *Reduced graph models for networks of thin co-axial electromagnetic cables*

Participants: Geoffrey Beck, Patrick Joly.

This work is the object of the PhD of Geoffrey Beck and is done in collaboration with Sébastien Imperiale (Inria, MEDISIM). The general context is the non destructive testing by reflectometry of electric networks of co-axial cables with heterogeneous cross section and lossy materials, which is the subject of the ANR project SODDA. We consider electromagnetic wave propagation in a network of thin coaxial cables (made of a dielectric material which surrounds a metallic inner-wire). The goal is to reduce 3D Maxwell’s equations to a quantum graph in which, along each edge, one is reduced to compute the electrical potential and current by solving 1D wave equations (the telegrapher’s model) coupled by vertex conditions. Using the method of matched asymptotics, we have derived and justified improved Kirchhoff conditions.

6.3.4. Geometrical transformations for waveguides of complex shapes

Participant: Jean-François Mercier.

In collaboration with Agnès Maurel from the Langevin Institut and Simon Felix from the LAUM, we have developed multimodal methods to describe the acoustic propagation in rigid waveguides of general shapes, with varying curvature and cross section. A key feature is the use of a flexible geometrical transformation to a virtual space in which the waveguide is straight but associated to Robin boundary conditions. We have revisited an efficient method developed earlier which consists in adding two extra non-physical modes to the usual modal expansion of the field on the Neumann guided modes, in order to obtain a better convergence of the modal series.

This method has been extended to a half guide with an end wall of general shape, transformed into a flat surface by a geometrical transformation, thus avoiding to question the Rayleigh hypothesis. The transformation only affects a bounded inner region that naturally matches the outer region, which allows to easily select the ingoing and outgoing waves.

6.4. Inverse problems

6.4.1. Quasi-Reversibility method and exterior approach for evolution problems

Participants: Eliane Bécache, Laurent Bourgeois.

This work is a collaboration with Jérémie Dardé from Toulouse University and has been the object of the internship of Lucas Franceschini, student at ENSTA. We address some linear ill-posed problems involving the heat or the wave equation, in particular the backward heat equation and the heat/wave equation with lateral Cauchy data. The main objective is to introduce some variational mixed formulations of quasi-reversibility which enable us to solve these ill-posed problems by using classical Lagrange finite elements. We have also designed a new approach called the “exterior approach” to solve inverse obstacle problems with initial condition and lateral Cauchy data for heat/wave equation. It is based on a combination of an elementary level set method and the quasi-reversibility methods we have just mentioned. Some numerical experiments have proved the feasibility of our strategy in all those situations.

6.4.2. Uniqueness and non-uniqueness results for the inverse Robin problem

Participant: Laurent Bourgeois.

This work is a collaboration with Laurent Baratchart and Juliette Leblond (Inria, APICS). We consider the classical Robin inverse problem, which consists in finding the ratio between the normal derivative and the trace of the solution (the Robin coefficient) on a subset of the boundary, given the Cauchy data (both the normal derivative and the trace of the solution) on the complementary subset. More specifically, we consider a Robin coefficient which is merely in L^∞ and a Neumann data in L^2 . In the $2D$ case we prove uniqueness of the Robin coefficient for a problem governed in a Lipschitz domain by a conductivity equation with a conductivity chosen in $W^{1,r}$, where $r > 2$. We also prove a non-uniqueness result in the $3D$ case. In two dimensions, the proof relies on complex analysis, while in higher dimension, the proof relies on a famous counterexample to unique continuation by Bourgain and Wolff.

6.4.3. Higher-order expansion of misfit functional for defect identification in elastic solids

Participants: Marc Bonnet, Rémi Cornaggia.

This work, done in the context of the PhD of Rémi Cornaggia, concerns the defect identification by time-harmonic elastodynamic measurements. We propose a generalization to higher orders of the concept of topological derivative, by expanding the least-squares functional in powers of the small radius of a trial inclusion. This expansion is facilitated by resorting to an adjoint state. With this approach, a region of interest may be exhaustively probed at reasonable computational cost.

6.4.4. Inverse scattering and invisibility with a finite set of emitted-received waves

Participant: Anne-Sophie Bonnet-Ben Dhia.

In collaboration with Lucas Chesnel from CMAP at Ecole Polytechnique and Sergei Nazarov from Saint-Petersburg University, we investigate a time harmonic acoustic scattering problem by a compactly supported penetrable inclusion in the free space. We consider cases where an observer can produce incident plane waves and measure the far field pattern of the resulting scattered field only in a finite set of directions. In this context, we say that a wavenumber is a non-scattering wavenumber if the associated relative scattering matrix has a non trivial kernel. Under certain assumptions on the physical coefficients of the inclusion, we have shown that the non-scattering wavenumbers form a (possibly empty) discrete set. Then, for a given real wavenumber, we built a constructive technique (which provides a numerical algorithm) to prove that there exist inclusions for which the corresponding relative scattering matrix is null. These inclusions have the important property to be impossible to detect from far field measurements.

6.4.5. Energy-based cost functional for three-dimensional transient elastodynamic imaging

Participant: Marc Bonnet.

This work is a collaboration with Wilkins Aquino (Duke University, USA). It is concerned with large-scale three-dimensional inversion under transient elastodynamic conditions by means of the modified error in constitutive relation (MECR), an energy-based, cost functional. Each evaluation of a time-domain MECR cost functional involves the solution of two elastodynamic problems (one forward, one backward), which moreover are coupled (unlike the case of L^2 misfit functionals). This coupling creates a major computational bottleneck, making MECR-based inversion difficult for spatially 2D or 3D configurations. To overcome this obstacle, we propose an approach whose main ingredients are (a) setting the entire computational procedure in a consistent time-discrete framework that incorporates the chosen time-stepping algorithm, and (b) using an iterative successive over-relaxation-like method for the resulting stationarity equations. The resulting MECR-based inversion algorithm is formulated under quite general conditions, allowing for 3D transient elastodynamics, straightforward use of available parallel solvers, a wide array of time-stepping algorithms commonly used for transient structural dynamics, and flexible boundary conditions and measurement settings. The proposed MECR algorithm is then demonstrated on computational experiments involving 2D and 3D transient elastodynamics and up to over 500 000 unknown elastic moduli.

6.5. Integral equations

6.5.1. Fast solution of the BEM system in 3-D frequency-domain elastodynamics

Participants: Stéphanie Chaillat, Patrick Ciarlet, Luca Desiderio.

The main advantage of the Boundary Element Method (BEM) is that only the domain boundaries are discretized leading to a drastic reduction of the total number of degrees of freedom. In traditional BE implementation the dimensional advantage with respect to domain discretization methods is offset by the fully-populated nature of the BEM coefficient matrix. Using the \mathcal{H} -matrix arithmetic and low-rank approximations (performed with Adaptive Cross Approximation), we derive a fast direct solver for the BEM system in 3-D frequency-domain elastodynamics. We assess the numerical efficiency and accuracy on the basis of numerical results obtained for problems having known solutions. In particular, we study the efficiency of low-rank approximations when the frequency is increased. The efficiency of the method is also illustrated to study seismic wave propagation in 3-D domains. This is done in partnership with SHELL company in the framework of the PhD of Luca Desiderio.

6.5.2. OSRC preconditioner for 3D elastodynamics

Participant: Stéphanie Chaillat.

This work is done in collaboration with Marion Darbas from University of Picardie and Frédérique Le Louer from Technological University of Compiègne. The fast multipole accelerated boundary element method (FM-BEM) is a possible approach to deal with scattering problems of time-harmonic elastic waves by a three-dimensional rigid obstacle. In 3D elastodynamics, the FM-BEM has been shown to be efficient with solution times of order $O(N \log N)$ per iteration (where N is the number of BE degrees of freedom). However, the number of iterations in GMRES can significantly hinder the overall efficiency of the FM-BEM. To reduce the number of iterations, we propose a clever integral representation of the scattered field which naturally incorporates a regularizing operator. When considering Dirichlet boundary value problems, the regularizing operator is a high-frequency approximation to the Dirichlet-to-Neumann operator, and is constructed in the framework of the On-Surface Radiation Condition (OSRC) method. This OSRC-like preconditioner is successfully applied to Dirichlet exterior problems in 3D elastodynamics.

6.5.3. *Boundary Integral Formulations for Modeling Eddy Current Testing*

Participants: Marc Bonnet, Audrey Vigneron.

This work was a part of the PhD thesis of Audrey Vigneron, and has been done in collaboration with Edouard Demaldent from CEA-List. It concerns the simulation of eddy current non-destructive testing, which aims to assess the presence of defects (cut, corrosion ...) in a conductive, and possibly magnetic, medium. We propose a simple block-SOR solution method for the PMCHWT-type Maxwell integral formulation, that is well suited for the low-frequency, high-conductivity limit typical of eddy current testing methods. We also derive an asymptotic expansion of the Maxwell integral formulation in powers of some relevant (small) non-dimensional number and show its relation to Hiptmair's eddy current integral formulation. Both aspects are validated on 3D numerical experiments.

6.6. Domain decomposition methods

6.6.1. *Transparent boundary conditions with overlap in elastic waveguides*

Participants: Anne-Sophie Bonnet-Ben Dhia, Sonia Fliss, Antoine Tonnoir.

This work is a part of the PhD of Antoine Tonnoir and is done in partnership with Vahan Baronian from CEA-LIST. We have conceived new transparent boundary conditions for the time-harmonic diffraction problem in an acoustic or elastic waveguide. These new conditions use the natural modal decomposition in the waveguide and are said "with overlap" by analogy with the domain decomposition methods. Among their main advantages, they can be implemented in general elastic anisotropic waveguides, for which usual Dirichlet to Neumann maps are not available. Moreover, the traditional benefit of the overlap for iterative resolution is obtained, independently of the size of the overlap.

6.6.2. *Electromagnetic scattering by objects with multi-layered dielectric coatings*

Participants: Patrick Joly, Matthieu Lecouvez.

This is the object of the PhD thesis of Matthieu Lecouvez in collaboration with the CEA-CESTA and Francis Collino. We are interested in the diffraction of time harmonic electromagnetic waves by perfectly conducting objects covered by multi-layered (possibly thin) dielectric coatings. This problem is computationally hard when the size of the object is large (typically 100 times larger) with respect to the incident wavelength. In such a situation, the idea is to use a domain decomposition method in which each layer would constitute a subdomain. The transmission conditions between the subdomains involve some specific impedance operators in order to achieve a geometric convergence of the method (compared to the slow algebraic convergence obtained with standard Robin conditions). We propose a practical solution that uses approximations of nonlocal integral operators with appropriate Riesz potentials.

6.6.3. *Domain Decomposition Methods for the neutron diffusion equation*

Participants: Patrick Ciarlet, Léandre Giret.

Studying numerically the steady state of a nuclear core reactor is expensive, in terms of memory storage and computational time. In particular, one must solve the neutron diffusion equation discretized by finite element techniques, totaling millions of unknowns or more, within a loop. Iterating in this loop allows to compute the smallest eigenvalue of the system, which determines the critical, or non-critical, state of the 3D core configuration. This problem fits within the framework of high performance computing so, in order both to optimize the memory storage and to reduce the computational time, one can use a domain decomposition method, which is then implemented on a parallel computer. The definition of an efficient DDM has been recently addressed for conforming meshes. The development of non-conforming, hence more flexible, methods is under way. Since one is dealing with highly heterogeneous configurations, the regularity of the exact solution can be very low, which then deteriorates the convergence rate of the discretized solution to the exact one. Next, the optimization of the eigenvalue loop will be studied.

This topic is developed in partnership with CEA-DEN (Erell Jamelot). Realistic computations are carried out with the APOLLO3 neutronics code.

6.7. Aeroacoustics

6.7.1. Time-harmonic acoustic scattering in a rotational flow

Participants: Antoine Bensalah, Patrick Joly, Jean-François Mercier.

This activity is done in the framework of the PhD of Antoine Bensalah, in partnership with EADS. We study the time-harmonic acoustic radiation in a fluid in a general flow which is not curl free, but has restricted vortical areas. The objective is to take into account the complicated coupling between acoustics and hydrodynamics. The Galbrun approach developed previously in 2D is too expensive in terms of degrees of freedom for 3D simulations. As an alternative, we propose to consider instead the Goldstein equations, which are vectorial only in the vortical areas and remain scalar elsewhere. Extending the proof done for the Galbrun equation, it is possible to prove that the Goldstein equations are well-posed in a domain Ω if the flow is Ω -filling (each point of Ω is reached by a streamline coming from the inflow boundary in a finite time). Then we focused on the case of a rotating flow in an annular geometry, which is not Ω -filling and we proved the well-posedness of the problem .

APICS Project-Team

6. New Results

6.1. Source recovery problems

Participants: Laurent Baratchart, Sylvain Chevillard, Juliette Leblond, Christos Papageorgakis, Olga Permiakova, Dmitry Ponomarev.

The research in this section is partly joint work with Qian Tao (Univ. Macao).

It was proved in [38] that a vector field with $n + 1$ components on \mathbb{R}^n can be expressed uniquely as the sum of (the trace on \mathbb{R}^n of) a harmonic gradient in the upper half-space, of (the trace on \mathbb{R}^n of) a harmonic gradient in the lower half-space, and of a tangential divergence free vector field on \mathbb{R}^n . This decomposition, that we call the *Hardy-Hodge* decomposition, is valid not only for L^p vector fields as mentioned in Section 3.3.1, but in much more general distribution spaces like $W^{-\infty,p}$ which contains all distributions with compact support or $BMO^{-\infty}$ which contains all finite sums of derivatives of bounded functions. This year we extended the decomposition to smooth hypersurfaces, where divergence-free distributions may be defined as those annihilating tangential gradient vector fields. We also studied the case where the hypersurface is only Lipschitz smooth, and then we proved the decomposition in L^p provided that p is close enough to 2 (how close depends on the Lipschitz constant of the hypersurface).

The Hardy-Hodge decomposition was used in [38] to find the kernel of the planar magnetization operator, namely a potential of the form (1) with m supported in a plane generates the zero field above that plane if, and only if there is no harmonic gradient from below in the Hardy-Hodge decomposition of m . The above mentioned generalization is now to the effect that a magnetization supported on a bounded closed surface (e.g. a sphere) is silent in the unbounded component of the complement of that surface if, and only if there is no harmonic gradient from inside in its Hardy-Hodge decomposition. An article is being written on this topic.

We also considered the case where m is compactly supported in the bounded component of the complement of that surface. Then m is silent if and only if it is the sum of a divergence-free distribution and of finitely many derivatives of gradients of Sobolev functions having zero trace on the surface [41].

These results shed light on the indeterminacy of inverse source problems.

6.1.1. EEG

This work is conducted in collaboration with Maureen Clerc and Théo Papadopoulo from the Athena EPI, and with Jean-Paul Marmorat (Centre de mathématiques appliquées - CMA, École des Mines de Paris).

In 3-D, functional or clinically active regions in the cortex are often modeled by point-wise sources that must be localized from measurements of a potential on the scalp. Inside the cortex, identified to a ball after the cortical mapping step, the potential satisfies a Poisson equation whose right-hand side is a linear combination of gradients of Dirac masses (the sources in EEG). In the work [3] it was shown how best rational approximation on a family of circles, cut along parallel planes on the sphere, can be used to recover the sources when they are at most 2 of them. Later, results on the behavior of poles in best rational approximation of fixed degree to functions with branch points [6] helped justifying the technique for finitely many sources (see section 4.2).

The dedicated software FindSources3D (see section 5.6), developed, in collaboration with the team Athena and the CMA, dwells on these ideas. Functions to be approximated in 2-D slices turn out to have additional *multiple* poles at their branch points so that, in the rational approximation step, it is beneficial to consider approximants with multiple poles as well (for EEG data, one should consider *triple* poles). Though numerically observed in [9], there is no mathematical justification so far why these multiple poles are attracted more strongly than simple poles to the singularities of the approximated function. This intriguing property, however, definitely helps source recovery [28]. This year we used it to automatically estimate the “most plausible”

number of sources (numerically: up to 3 at the moment). Such enhancements were prompted by a developing collaboration with the BESA company, which is interested in automatic detection of the number of sources (which was left to the user until recently).

Soon, magnetic data from MEG (magneto-encephalography) will become available together with EEG data; indeed, it is now possible to use simultaneously the corresponding measurement devices. We expect this to improve the accuracy of our algorithms.

In relation to other brain exploration modalities like electrical impedance tomography (EIT, see [16]), we also consider identifying electrical conductivity in the head. This is the topic of the PhD of C. Papageorgakis, co-advised with the Athena project-team and BESA GmbH. Specifically, in layered models, we are concerned with estimating conductivity of the skull (intermediate layer). Indeed, the skull consists of a hard bone part, the conductivity of which is more or less known, and spongy bone compartments whose conductivities may vary considerably with individuals.

A preliminary question in this connection is: can one uniquely recover a homogeneous skull conductivity from a single EEG recording when the sources and the conductivities of other layers are known? And if sources are not known, which additional information do we need? These are issues currently under investigation. To put them into perspective, recall the famous Caldèron problem of deducing a bounded (nonconstant) conductivity from the knowledge of all possible pairs consisting of a potential and its current flux at the boundary. In dimension 3, when the conductivity is not smooth (less than $3/2$ of a derivative), it is unknown whether the problem is even injective (*i.e.* if two conductivities can have the same pairs of boundary potential and flux). A weaker, discrete version of this problem is: if the conductivity takes on finitely many values and the geometry of the level sets is known, does a finite set of pairs of boundary potential and flux allow one to recover it? This is a significant question to be tackled for the purpose of source recovery in EEG with known geometry but unknown conductivities inside the head.

6.1.2. Inverse Magnetization problems

This work is carried out in the framework of the “équipe associée Inria” IMPINGE, comprising Eduardo Andrade Lima and Benjamin Weiss from the Earth Sciences department at MIT (Boston, USA) and Douglas Hardin and Edward Saff from the Mathematics department at Vanderbilt University (Nashville, USA),

Localizing magnetic sources from measurements of the magnetic field away from the support of the magnetization is the fundamental issue under investigation by IMPINGE. The goal is to determine magnetic properties of rock samples (*e.g.* meteorites or stalactites), from fine field measurements close to the sample that can nowadays be obtained using SQUIDS (superconducting coil devices). Currently, rock samples are cut into thin slabs and the magnetization distribution is considered to lie in a plane, which makes for a somewhat less indeterminate framework than EEG because “less” magnetizations can produce the same field (for the slab has no inner volume). Note however that EEG data consist of both potential and current values at the boundary, whereas in the present setting only values of the normal magnetic field are provided to us.

Figure 5 presents a schematic view of the experimental setup: the sample lie on a horizontal plane at height 0 and its support is included in a rectangle. The vertical component B_z of the field produced by the sample is measured on points of a horizontal $N \times N$ rectangular grid at height h .

We set up last year a heuristic procedure to recover regularly spaced dipolar magnetizations, *i.e.* magnetizations composed of dipoles placed at the points of a regular rectangular $n \times n$ grid. The latter seems general enough a model class to approximate magnetizations commonly encountered in samples. However, for reasons of computational complexity, n is significantly smaller than N which limits the power of the model. Each dipole of the $n \times n$ grid is determined by the 3 components of its moment, thus the magnetization can be represented by a real $3n^2$ -vector. If we denote by A the matrix of the operator that maps such a vector X to the vector b of measurements (which belongs to \mathbb{R}^{N^2}), we want to find X such that AX is close to b . For computational simplicity, we use a Euclidean criterion $\|AX - b\|_2$, which reduces the problem to a singular value decomposition of A . The inverse problem being ill-posed, A is poorly conditioned and we must resort to a regularization technique. The one we developed initially has been based on iteratively cropping the support of b , using a threshold on the intensity of the dipoles at each step, so as to reduce the number of active components

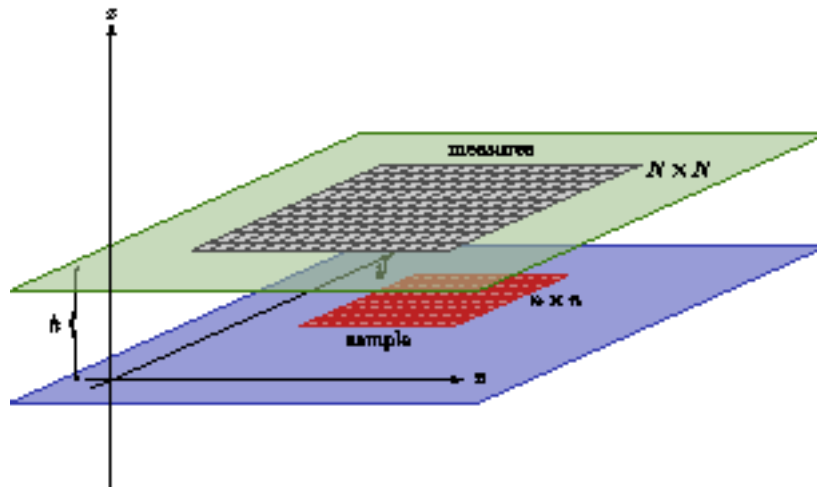

Figure 5. Schematic view of the experimental setup

in b . Preliminary experiments were performed last year on synthetic data and also on a real example (Lunar spherule).

This year, we performed more systematic experiments on real data (namely Allende chondrules and Hawaiian basalt) provided by the SQUID scanning microscope at MIT lab. Cropping the support of b using thresholding has proved efficient to improve ill-conditioning for samples with localized support embedded in the slab (e.g., chondrules). On the other hand, when the support of the sample is spread out (e.g., Hawaiian basalt), the reduction of active components of b was insignificant. We used this inversion procedure to estimate the net moment. The importance of the latter has been emphasized by the geophysicists at MIT for at least two reasons: firstly it yields important geological information on the sample in particular to estimate the magnitude of the ambient magnetic field at the time the rock was formed. Secondly, it may to some extent be measured independently, using a magnetometer, thereby allowing one to cross-validate the approach. A third, computational reason is that knowledge of the net moment should pave the way to a numerically stable reconstruction of an equivalent unidirectional magnetization. The support of the latter would provide us with valuable information to test for unidirectionality of the true magnetization, which is an important question to physicists.

When the support can be significantly shrunk while keeping the residue small (i.e., explaining the data satisfactorily), estimates of the net moment based on the dipolar model obtained by inversion seem to be good. They apparently supersede the measurements by magnetometers as well as by dipole fitting procedures set up at MIT. It is interesting to notice that the magnetization obtained by our inversion procedure, either before or after shrinking the support, often does not resemble the true magnetization, even when it yields correct moment and field. This can be seen on synthetic examples and may be surmised on real data, thereby confirming that recovering the net moment and recovering the magnetization are rather different problems, the latter being considerably more ill-posed than the former.

One specific difficulty with chondrule-type examples has been to account for their thickness: they are indeed small spheres and their 3-D character cannot be completely ignored. In order to use the inversion procedure set up in the plane, we investigated the following question. Assume that the sample has some thickness, but small enough that the magnetization at a point $P = (x, y, z)$ inside the sample depends only on x and y (possibly weighted by some function that depends only on z), i.e. that it is of the form $m(x, y)\phi(z)$. If we consider a (truly) planar magnetization with the same distribution $m(x, y)$ but on a plane lying at some nonzero height

ε , how to choose ε so as to produce a field at height h which is closest to the field produced by the thick magnetization? This has been the object of the internship of Olga Permiakova who used local expansion of the dipole-to-field map (see her report ⁰). An article is being written on this subject.

The case where the magnetization is flat but spread out on the sample is more difficult. First of all, the computational effort becomes significant and led us to use the cluster at Inria Sophia Antipolis. We succeeded in obtaining full inversions for the Hawaiian basalt. The residue (approximation error) is moderate but not impressively small, which indicates that we reach the limit of modeling magnetizations by a regular grid of dipoles. However the computation of the moment compares favorably with estimates previously obtained by a different technique at MIT lab. Still, using a cluster and two days of evaluation to obtain a coarse estimate of the net moment of a sample is rather inefficient and calls for new investigations.

We also experimented an alternative regularization procedure, based on L^2 minimization under L^1 penalty as solved by the SALS algorithm. Such methods are quite popular today for sparse recovery. However, the computational load, as well as the quality of the results, do not differ significantly from those obtained previously.

We now develop new methods in order to estimate the net moment of the magnetization, based on improvements of previously used Fourier techniques, and recently we reformulated the problem with the help of Kelvin transforms. It has been realized that the success of net moment recovery hinges on the ability to extrapolate the measurements. In particular, we managed to considerably improve previous estimates by means of data extension based on dipolar field asymptotics.

In the course of inverting the field map, we singled out magnetizations which are numerically (almost) silent from above though not from below. This illustrates how ill-posed (unstable) the problem, as theory predicts that no compactly supported magnetization can be exactly silent from above without being also exactly silent from below. Although such magnetizations seem to have small moment and therefore do not endanger the possibility of recovering the net moment, their existence is certainly an obstacle to inversion of the field map without extra measurements or hypotheses (*e.g.*, measuring from below or assuming unidirectionality).

In the course of the doctoral work by D. Ponomarev, the study of the 2D spectral decomposition of the truncated Poisson operator has been undertaken. It is a simplified version of the relation between the magnetization and the magnetic potential. We considered several formulations in terms of singular integral equations and matrix Riemann-Hilbert problems, and focused on finding closed form solutions for various approximations of the Poisson operator in terms of a the ratio between the distance h to the measurement plane and the sample support size.

Lately, Apics became a partner of the ANR project MagLune, dealing with Lunar magnetism, a in collaboration with the Geophysics and Planetology Department of Cerege, CNRS, Aix-en-Provence, see section 8.2.2 . The research is just starting, and will focus on computing net moments of lunar rock samples collected by NASA.

6.2. Boundary value problems

Participants: Laurent Baratchart, Sylvain Chevillard, Juliette Leblond, Dmitry Ponomarev.

Collaboration with Laurent Bourgeois (ENSTA ParisTech, Lab. Poems), Elodie Pozzi (Univ. Bordeaux, IMB), Emmanuel Russ (Univ. Grenoble, IJF).

Generalized Hardy classes

As we mentioned in section 4.4 , 2-D diffusion equations of the form $\operatorname{div}(\sigma \nabla u) = 0$ with real non-negative valued conductivity σ can be viewed as compatibility conditions for the so-called conjugate Beltrami equation: $\bar{\partial} f = \nu \bar{\partial} \bar{f}$ with $\nu = (1 - \sigma)/(1 + \sigma)$ [4]. Thus, the conjugate Beltrami equation is a means to replace the initial second order diffusion equation by a first order system of two real equations, merged into a single complex one. Hardy spaces under study here are those of this conjugate Beltrami equation: they are comprised of solutions to that equation in the considered domain whose L^p means over curves tending to the boundary

⁰http://www-sop.inria.fr/apics/IMPINGE/Documents/Report_Permiakova_Olga.pdf

of the domain remain bounded. They will for example replace holomorphic Hardy spaces in problem (P) when dealing with non-constant (isotropic) conductivity. Their traces merely lie in L^p ($1 < p < \infty$), which is suitable for identification from point-wise measurements, and turn out to be dense on strict subsets of the boundary. This allows one to state Cauchy problems as bounded extremal issues in L^p classes of generalized analytic functions, in a manner which is reminiscent of what we discussed for analytic functions in section 3.3.1 .

The study of such Hardy spaces for Lipschitz σ was reduced in [4] to that of spaces of pseudo-holomorphic functions with bounded coefficients, which were apparently first considered on the disk by S. Klimentov. Solutions factorize as $e^s F$, where F is a holomorphic Hardy function while s is in the Sobolev space $W^{1,r}$ for all $r < \infty$ (Bers factorization), and the analog to the M. Riesz theorem holds which amounts to solvability of the Dirichlet problem with L^p boundary data. The case of finitely connected domains was carried out in [14].

This year, we addressed in [25] the uniqueness issue for the classical Robin inverse problem on a Lipschitz-smooth domain $\Omega \subset \mathbb{R}^n$, with L^∞ Robin coefficient, L^2 Neumann data and isotropic conductivity of class $W^{1,r}(\Omega)$, $r > n$. The Robin inverse problem consists in recovering the ratio of the normal derivative and the solution (the so-called Robin coefficient) on a subset of the boundary, knowing them on the complementary subset. We showed that uniqueness of the Robin coefficient on a subset of the boundary, given Cauchy data on the complementary subset, does hold when $n = 2$ whenever the boundary subsets are of positive Lebesgue measure. We also showed that this no longer holds in higher dimension, and we gave counterexamples when $n = 3$. The subsets in these counterexamples look very bad, and it is natural to ask whether uniqueness prevails if they have interior points. This raises an interesting open issue on harmonic gradients, namely: can a nonzero harmonic function vanish together with its normal derivative on a subset of the boundary of positive measure, and still the Robin coefficient is bounded in a neighborhood of that set? This question is worth investigating

Best constrained analytic approximation

Several questions about the behavior of solutions to the bounded extremal problem (P) in section 3.3.1 , and of some generalizations thereof, are still under study by Apics.. We considered additional interpolation constraints on the disk in problem (P) , and derived new stability estimates for the solution [24]. An article is being written on the subject. Ongoing work is geared towards applications of [24]. New insight leads us to relate these results to overdetermined boundary value problems for 2D Laplace equations on irregular boundaries. This has applications in set-ups where measurements are obtained from oddly distributed sensors. Treating some of the measurements as pointwise interpolation constraints seems a reasonable strategy in comparison with interpolation of the data along a geometrically complicated boundary. Such interpolation constraints arise naturally in inverse boundary problems like plasma shaping, when some of the measurements are performed inside the chamber of the tokamak, see section 4.4 .

6.3. Matching problems and their applications - De-embedding of filters in multiplexers

Participants: Laurent Baratchart, Martine Olivi, Sanda Lefteriu, David Martinez Martinez, Fabien Seyfert.

This work has been done in collaboration with Stéphane Bila (Xlim, Limoges, France), Hussein Ezzedin (Xlim, Limoges, France), Damien Pacaud (Thales Alenia Space, Toulouse, France), Giuseppe Macchiarella (Politecnico di Milano, Milan, Italy), and Matteo Oldoni (Siae Microelettronica, Milan, Italy).

6.3.1. Matching problems and their applications

Filter synthesis is usually performed under the hypothesis that both ports of the filter are loaded on a constant resistive load (usually 50 Ohm). In complex systems, filters are however cascaded with other devices, and end up being loaded, at least at one port, on a non purely resistive frequency varying load. This is for example the case when synthesizing a multiplexer: each filter is here loaded at one of its ports on a common junction. Thus, the load is by construction non constant with the frequency, and not purely resistive either. Likewise, in an emitter-receiver, the antenna is followed by a filter. Whereas the antenna can usually be regarded as a resistive load at some frequencies, this is far from being true on the whole working band. A mismatch between

the antenna and the filter, however, causes irremediable power losses, both in emission and transmission. Our goal is therefore to develop a filter synthesis method that allows to match varying loads on specific frequency bands.

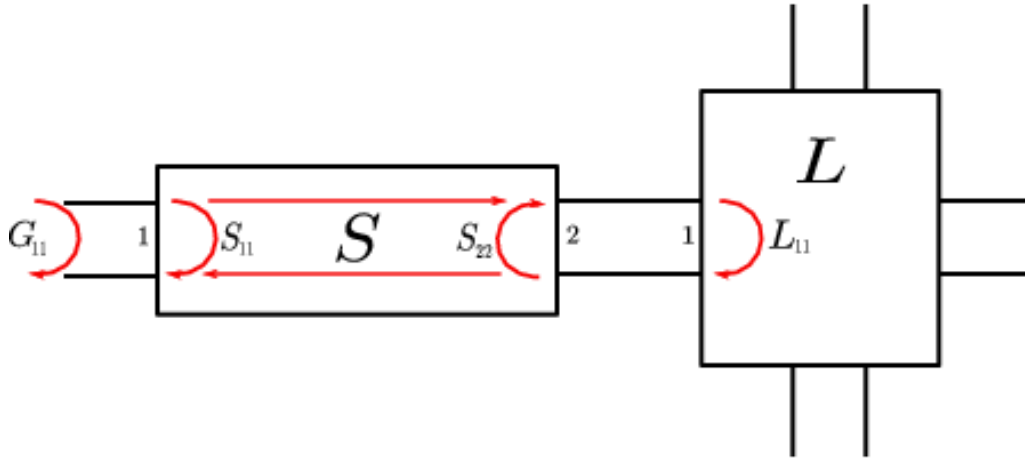

Figure 6. Filter plugged on a system with reflexion coefficient L_{11}

Figure 6 shows a filter with scattering matrix S , plugged at its right port on a frequency varying load with reflexion parameter $L_{1,1}$. If the filter is lossless, simple algebraic manipulations show that on the frequency axis the reflexion parameter satisfies:

$$|G_{1,1}| = \left| \frac{S_{2,2} - \overline{L_{1,1}}}{1 - S_{2,2}L_{1,1}} \right|.$$

The matching problem of minimizing $|G_{1,1}|$ amounts therefore to minimize the pseudo-hyperbolic distance between the filter's reflexion parameter $S_{2,2}$ and the load's reflexion $L_{1,1}$, on a given frequency band. For a broad class of filters, namely those that can be modeled by a circuit of n coupled resonators, the scattering matrix S is a rational function of McMillan degree n in the frequency. The matching problem appears therefore as a rational approximation problem in hyperbolic metric. When n is fixed, the latter is non-convex and led us to seek methods to derive good initial guesses for classical descent algorithms. To this effect, if $S_{2,2} = p/q$ we considered the following interpolation problem: given n frequency points $w_1 \cdots w_n$ and a transmission polynomial r , to find a unitary polynomial p of degree n such that:

$$j = 1..n, \quad \frac{p}{q}(w_j) = \overline{L_{1,1}(w_j)}$$

where q is the unique monic Hurwitz polynomial of degree n satisfying the Feldtkeller equation

$$qq^* = pp^* + rr^*,$$

which accounts for the losslessness of the filter. This problem can be seen as an extended Nevanlinna-Pick interpolation problem, that was considered in [67] when the interpolation points w_j lie in the *open* left half-plane. The method in the last reference does not extend to imaginary interpolation point and we used rather different, differential-topological techniques to prove that this problem has a unique solution, which can be computed by continuation. In the setting of multiplexer synthesis, where this result must be applied recursively to each filter, we showed the existence of a fixed point for the tuning procedure, based on Brouwer's fixed point theorem. These results were presented at the MTNS [18], at the plenary of session of Ernsi workshop 2014, and they lie at the heart of the ANR Cocoram on co-integration of filters and antennas (8.2.1). Implementation of the continuation algorithm has been done under contract with CNES and yields encouraging results. Generalizations of the interpolation problem where the monic condition is relaxed are under study in the framework of co-integration of filters and antennas.

6.3.2. De-embedding of multiplexers

This work is pursued in collaboration with Thales Alenia Space, Siae Microelettronica, Xlim and under contract with CNES-Toulouse (see section 7.1).

Let S be the scattering parameters of a multiplexer composed of a N -port junction with response T and $N - 1$ filters with responses F_1, \dots, F_{N-1} , as plotted on Figure 7. The de-embedding problem is to recover the F_k and it can be stated under various hypotheses. Last year we studied this problem when S and T are known [79] but no special structure for the F_k is assumed. It was shown that for generic T and for $N > 3$, the de-embedding problem has a unique solution. In practice, however, the junction's response is far from being generic, as it is usually obtained *via* assembly of T-junctions. This makes the problem extremely sensitive to measurement noise. It was also noticed that in practical applications, scattering measurements of the junction are hardly available.

It is therefore natural to consider the following de-embedding problem. Given S , and under the assumption that

- the F_k are rational of known McMillan degree,
- the coupling geometry of their circuital realization is known,

what can be said about the filter's response? Note that the above assumptions do not bear on the junction. Nevertheless, we showed that the filter's responses are identifiable up to a constant matrix chained at their nearest port to the junction [73]. It was proved also that the uncertainty induced by the chain matrix bears only on the resonant frequency of the last cavity of each filter, as well as on their output coupling. Most of the filters' parameters can therefore be recovered in principle. The approach is constructive and relies on rational approximation to certain scattering parameters, as well as on some extraction procedure similar to Darlington's synthesis. Software development is under way and experimental studies have started on data provided to us by Thales Alenia Space and by Siae Microelettronica. A mid-term objective is to extend Presto-HF (see Section 5.3) so as to handle de-embedding problems for multiplexers and more generally for multi-ports.

6.4. Stability of amplifiers

Participants: Laurent Baratchart, Sylvain Chevillard, Martine Olivi, Fabien Seyfert.

This work is performed under contract with CNES-Toulouse and the University of Bilbao. The goal is to help designing amplifiers, in particular to detect instability at an early stage of the design.

Currently, electrical engineers from the University of Bilbao, under contract with CNES (the French Space Agency), use heuristics to detect instability before an amplifying circuit is physically built. Our goal is to set up a rigorously founded algorithm, based on properties of transfer functions of such amplifiers, which belong to particular classes of analytic functions.

In non-degenerate cases, non-linear electrical components can be replaced by their first order approximation when studying stability in the small signal regime. Using this approximation, diodes appear as negative resistors and transistors as current sources controlled by the voltage at certain nodes of the circuit.

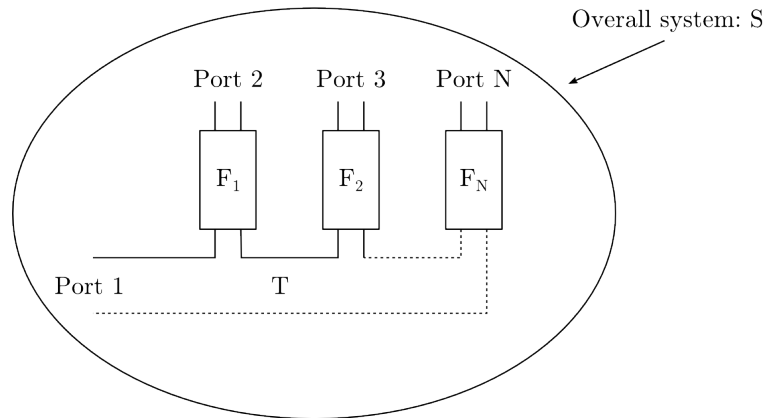

Figure 7. Multiplexer made of a junction T and filtering devices $F_1, F_2 \dots F_N$

Over the last three years, we studied several features of transfer functions of amplifying electronic circuits:

- We characterized the class of transfer functions which can be realized with ideal components linearized active components, together with standard passive components (resistors, inductors, capacitors and transmission lines). It is exactly the field of rational functions in the complex variable and in the hyperbolic cosines and identity-times-hyperbolic sines of polynomials of degree 2 with real negative roots.
- We introduced a realistic notion of stability, by terming stable a circuit whose transfer function belongs to H^∞ , as long a sufficiently high resistor is added in parallel to that circuit.
- We constructed unstable circuits having no pole in the right half-plane, which came as a surprise to our partners.
- In order to circumvent these pathological examples, we introduced a realistic hypothesis that there are small inductive and capacitive effects to active components. Our main result is that a realistic circuit without poles on the imaginary axis is unstable if and only if it has poles in the right half-plane. Moreover, there can only be finitely many of them.

This year, we were led to modify our definition of stability, taking a hint from scattering theory. We say that a transfer function Z is stable whenever $(R - Z)/(R + Z)$ belongs to H^∞ with uniformly bounded H^∞ -norm for all R large enough. Equivalently, this means that the circuit can amplify signals but not require an unbounded amount of energy from the primary power circuit. This new definition is really about energy, hence is more natural. Also, it allows us a unified characterization in the corner case where instabilities are located on the imaginary axis. We obtained this way a nice characterization: Z is stable if and only if it has no pole in the open right half plane, while each pole it may have on the imaginary axis is simple and has a residue with strictly positive real part. We published a research report [23] and an article is being written to report on our results.

6.5. Approximation

Participant: Laurent Baratchart.

6.5.1. Orthogonal Polynomials

This is joint work with Nikos Stylianopoulos (Univ. of Cyprus).

We study the asymptotic behavior of weighted orthogonal polynomials on a bounded simply connected plane domain Ω . The n -th orthogonal polynomial P_n has degree n , positive leading coefficient, and satisfies

$$\int_{\Omega} P_n \bar{P}_k w \, dm = \delta_{n,k}$$

where w is an integrable positive weight and $\delta_{n,k}$ is the Kronecker symbol. When Ω is smooth while w is Hölder-continuous and non-vanishing, it is known that

$$P_n(z) = \left(\frac{n+1}{\pi} \right)^{1/2} \Phi^n \frac{\Phi'}{S_w(z)} \{1 + o(1)\},$$

locally uniformly outside the convex hull of $\bar{\Omega}$, where Φ is the conformal map from the complement of Ω onto the complement of the unit disk and S_w is the so-called Szegő function of the trace of w on the boundary $\partial\Omega$ [81]. If we compare it with classical exterior Szegő asymptotics, the formula asserts that P_n behaves asymptotically like the n -th orthogonal polynomial with respect to a weight supported on $\partial\Omega$ (the trace of w), up to a factor $\sqrt{(n+1)/\pi}$.

When Ω is the unit disk, we proved this result under unprecedented weak assumptions on w , namely $w(re^{i\theta})$ should converge in $L^p(T)$ as $r \rightarrow 1$ for some $p > 1$ and its \log^- should be bounded in the real Hardy space H^1 . An article is being written on these findings and the case of a smooth domain Ω , more general than a disk, is under examination.

6.5.2. Meromorphic approximation

This is joint work with Maxim Yattselev (Purdue Univ. at Indianapolis, USA).

We proved in [6] that the normalized counting measure of poles of best H^2 approximants of degree n to a function analytically continuable, except over finitely many branchpoints lying outside the unit disk, converges to the Green equilibrium distribution of the compact set of minimal Green capacity outside of which the function is single valued (the normalized counting measure is the probability measure with equal mass at each pole). This result warrants source recovery techniques used in section 6.1.1. Here we consider the corresponding problem for best uniform meromorphic approximants on the unit circle (so-called AAK approximants after Adamjan, Arov and Krein), in the case where the function may have poles and essential singularities. This year, we established a similar result when the function has finitely many essential singularities. The general case is still pending.

BIPOP Project-Team

6. New Results

6.1. Highlights of the Year

- Bernard Brogliato: keynote speaker at ICDVC-2014, 4th International Conference on Dynamics, Vibration and Control, August 23-25, 2014 in Shanghai, China. <http://www.icdvc2014.org/>

6.2. Multiple impacts modelling

Participant: Bernard Brogliato.

The work consists of studying two systems: the rocking block and tapered chains of balls, using the Darboux-Keller model of multiple impacts previously developed. The objectives are threefold: 1) show that the model predicts well the motion by careful comparisons with experimental data found in the literature, 2) study the system's dynamics and extract critical kinetic angles that allow the engineer to predict the system's gross motion, 3) develop numerical code inside the SICONOS platform that incorporates the model of multiple impact. The influence of the kinetic angles in the rocking block motion with friction is analysed as well, numerically. Extensive experimental works have been conducted by our colleague C. Liu at PKU on a disc-ball system. Results are in [32] [67], and in the monograph [16]. Multiple impacts have also been tackled through generalized kinematic models using the kinetic metric [20].

6.3. The contact complementarity problem

Participants: Bernard Brogliato, Florence Bertails-Descoubes, Alejandro Blumentals.

The contact linear complementarity problem is an set of equalities and complementarity conditions whose unknowns are the acceleration and the contact forces. It has been studied in a frictionless context with possibly singular mass matrix and redundant constraints in [21], using results on well-posedness of variational inequalities obtained earlier by the authors. This is also the topic of the first part of the Ph.D. thesis of Alejandro Blumentals where the frictional case is treated as a perturbation of the frictionless case. The contact LCP is directly related to the so-called Painlevé's paradox of contact mechanics. In collaboration with C. Liu (Beijing university PKU) some results have been obtained from the analysis of a compliant model in the limit. It shows on the classical sliding rod system that the inconsistent mode yield to instantaneous transition to a sticking mode. This is quite coherent with previous results obtained by Le xuan Anh in 1991 on the Painlevé-Klein system (bilateral constraints with Coulomb friction). The results will appear in *Multibody System Dynamics* in 2015.

6.4. Discrete-time sliding mode control

Participants: Vincent Acary, Bernard Brogliato, Olivier Huber.

This topic concerns the study of time-discretized sliding-mode controllers. Inspired by the discretization of nonsmooth mechanical systems, we propose implicit discretizations of discontinuous, set-valued controllers. This is shown to result in preservation of essential properties like simplicity of the parameters tuning, suppression of numerical chattering, reachability of the sliding surface after a finite number of steps, and disturbance attenuation by a factor h or h^2 [41], [42], [43], [45], [61]. This work is part of the ANR project CHASLIM. Within the framework of CHASLIM we have performed many experimental validations on the electropneumatic setup of IRCCyN (Nantes), which nicely confirm our theoretical and numerical predictions: the implicit implementation of sliding mode control, drastically improves the input and output chattering behaviours. In particular the high frequency bang-bang controllers which are observed with explicit discretizations, are completely suppressed. The implicit discretization has been applied to the classical equivalent-based-control SMC, and also to the twisting sliding-mode controller [43].

6.5. Lur'e set-valued dynamical systems

Participants: Bernard Brogliato, Christophe Prieur.

Lur'e systems are quite popular in Automatic Control since the fifties. Set-valued Lur'e systems possess a static feedback nonlinearity that is a multivalued function. This study consists in the mathematical analysis (existence and uniqueness of solutions) and the stability analysis (Lyapunov stability, invariance principle) of classes of set-valued Lur'e systems, with applications in complementarity dynamical systems, relay systems, mechanical systems with dry friction, electrical circuits, etc. Our works in this field started in [62]. The results in [64] extend those in [63] with an accurate characterization of the maximal monotonicity of the central operator of these systems, which consists of a projection-like operator. Concrete and verifiable criteria are provided for the above classes (complementarity, relay systems). Results on state observers and output feedback control for classes of Lur'e systems (namely: Moreau's sweeping process of first and second order, and with prox-regular sets) are proposed in [29], [44], [34]. Therein the convexity is replaced by the far more general notion of prox-regularity, which destroys the monotonicity. The input to state stability of measure driven differential equations has been tackled in [22], where some results from [29] are adapted.

6.6. Simulation and stability of piecewise linear gene networks

Participants: Vincent Acary, Arnaud Tonnelier, Bernard Brogliato.

This work has been done in collaboration with the IBIS project team, it is reported in [19]. Gene regulatory networks control the response of living cells to changes in their environment. A class of piecewise-linear (PWL) models, which capture the switch-like interactions between genes by means of step functions, has been found useful for describing the dynamics of gene regulatory networks. The step functions lead to discontinuities in the right-hand side of the differential equations. This has motivated extensions of the PWL models based on differential inclusions and Filippov solutions, whose analysis requires sophisticated numerical tools. We present a method for the numerical analysis of one proposed extension, called Aizerman-Pyatnitskii (AP)-extension, by reformulating the PWL models as a mixed complementarity system (MCS). This allows the application of powerful methods developed for this class of nonsmooth dynamical systems, in particular those implemented in the Siconos platform. We also show that under a set of reasonable biological assumptions, putting constraints on the right-hand side of the PWL models, AP-extensions and classical Filippov (F)-extensions are equivalent. This means that the proposed numerical method is valid for a range of different solution concepts. We illustrate the practical interest of our approach through the numerical analysis of three well-known networks developed in the field of synthetic biology.

In addition, we have investigated oscillatory regimes in repressilator-type models with piecewise linear dynamics [30]. We derived exact analytical conditions for oscillations and showed that the relative location between the dissociation constants of the Hill functions and the ratio of kinetic parameters determines the possibility of oscillatory activities. We also computed analytically the probability of oscillations. Results suggest that a switch-like coupling behaviour, a time-scale separation and a repressilator-type architecture with an even number of elements facilitate the emergence of sustained oscillations in biological systems.

6.7. Numerical analysis and simulation of mechanical systems with constraints

6.7.1. Event-capturing schemes for nonsmooth mechanical systems

Participant: Vincent Acary.

To perform the numerical time integration of nonsmooth mechanical systems, the family of event-capturing time-stepping schemes are the most robust and efficient tools. Nevertheless, they suffer from several drawbacks : a) a low-order accuracy (at best at order one), b) a drift phenomena when the unilateral constraints are treated at the velocity level and c) a poor "energetic" behavior in terms of stabilizing the high-frequency dynamics. We proposed self-adapting schemes by applying time-discontinuous Galerkin methods to the measure differential equation in [28]. In order to satisfy in discrete time, the impact law and the constraints at the position and the velocity level, an adaptation of the well-known Gear-Gupta-Leimkuhler approach has been

developed. In [58], the approach is algorithmically specified, improved and applied to nonlinear multi-contact examples with friction. It is compared to other numerical schemes and it is shown that the newly proposed integration scheme yields a unified behavior for the description of contact mechanical problems. Especially, we provide time-integration of the nonimpulsive dynamics with semi-explicit Runge–Kutta method previously developed for differential algebraic equations.

6.7.2. Numerical time–integration methods for event-detecting schemes.

Participants: Vincent Acary, Bernard Brogliato, Mounia Haddouni.

The CIFRE thesis of M. Haddouni concerns the numerical simulation of mechanical systems subject to holonomic bilateral constraints, unilateral constraints and impacts. This work is performed in collaboration with ANSYS and the main goal is to improve the numerical time–integration in the framework of event-detecting schemes. Between nonsmooth events, time integration amounts to numerically solving a differential algebraic equations (DAE) of index 3. We have compared dedicated solvers (Explicit RK schemes, Half-explicit schemes, generalizes α -schemes) that solve reduced index formulations of these systems. Since the drift of the constraints is crucial for the robustness of the simulation through the evaluation of the index sets of active contacts, we have proposed some recommendations on the use of the solvers of dedicated to index-2 DAE. A manuscript has been submitted to Multibody System Dynamics.

6.7.3. Multibody systems with clearances (dynamic backlash)

Participants: Vincent Acary, Bernard Brogliato, Narendra Akadkhar.

The PhD thesis of N. Akadkhar under contract with Schneider Electric concerns the numerical simulation of mechanical systems with unilateral constraints and friction, where the presence of clearances in imperfect joints plays a crucial role. A first work deals with four-bar planar mechanisms with clearances at the joints, which induce unilateral constraints and impacts, rendering the dynamics nonsmooth. The objective is to determine sets of parameters (clearance value, restitution coefficients, friction coefficients) such that the system's trajectories stay in a neighborhood of the ideal mechanism (*i.e.* without clearance) trajectories. The analysis is based on numerical simulations obtained with the projected Moreau-Jean time-stepping scheme. These results have been reported in [37]. It is planned to extend these simulations to frictional cases and to mechanisms of circuit breakers.

6.8. Inverse modeling with contact and friction

6.8.1. Inverse statics of plates and shells

Participants: Florence Bertails-Descoubes, Romain Casati, Gilles Daviet.

We have started to investigate the problem of interpreting an arbitrary 3D mesh as an equilibrium configuration of an elastic plate/shell, subject to gravity and frictional contact forces. We have first considered a simple nodal shell model accounting for stretch, shear and bending. For such a model, inverse statics formulates as an ill-posed minimization problem with a nonlinear objective and nonsmooth constraints. Our objective is to examine this problem in the case where the rest pose of the system is left as unknown, while material parameters (mass, stiffness) are assumed to be known (inverse design problem). In some specific cases (cloth modeling), we use a priori information such as locally low Gaussian curvature so as to help the retrieval of most natural solutions. We plan to submit our results to Siggraph 2015. Targeted applications include virtual garment modeling and parameter retrieval from 3D image-based capture.

6.9. Modeling of fibrous medium

6.9.1. Continuous modeling of fiber assemblies

Participants: Florence Bertails-Descoubes, Gilles Daviet.

Following the exploratory project funded by Persyval (2013-2014), we have started to model an assembly of long elastic fibers (such as hair) using a continuous approach (continuum mechanics equations coupled with a nonsmooth stress-strain law). Interactions between air and fibers can then be naturally accounted for, increasing the realism of some macroscopic features compared to our previous discrete elements model. This is still work in progress and we will make some of our results publicly available in 2015.

6.10. Threshold in spiking neural models

Participant: Arnaud Tonnelier.

We studied the threshold for spike initiation in two-dimensional spiking neural models. A threshold criterion that depends on both the membrane voltage and the recovery variable is proposed. This approach provides a simple and unified framework that accounts for numerous voltage threshold properties. Implications for neural modeling are also discussed [31].

6.11. Nonsmooth modes in chains of impact oscillators

Participants: Vincent Acary, Guillaume James, Franck P erignon.

Chains of impact oscillators arise for example as finite-element models of thin oscillating mechanical structures (a string under tension or a clamped beam) contacting rigid obstacles. Nonlinear periodic waves are observed in experiments on such systems, but relatively little is known from a theoretical point of view on their existence and stability. In 2008, Gendelman and Manevitch have analyzed the existence and stability of nonlinear localized modes (breathers) for discrete linear chains with a single node undergoing rigid impacts. In this work, we introduce a numerical method allowing to compute branches of time-periodic solutions when an arbitrary number of nodes undergo rigid impacts without energy dissipation. For this purpose, we reformulate the search of periodic solutions as a boundary value problem incorporating unilateral constraints. We illustrate this numerical approach by computing different families of breathers and nonlinear normal modes. Our method is much more effective than a numerical continuation of periodic solutions based on compliant models, which requires to integrate stiff differential equations and lead to costly numerical continuation. These results have been communicated in two international conferences, ENOC 2014 [35] and 11th World Congress on Computational Mechanics [36].

6.12. Traveling waves in spatially discrete excitable media

Participants: Jos e Eduardo Morales, Arnaud Tonnelier, Guillaume James.

The propagation of traveling waves in excitable media is a widespread phenomenon, with applications ranging from forest fires to electrical signals propagating along nerve fibers. The case of spatially discrete excitable models is notoriously difficult to analyze. In particular, for the discrete FitzHugh-Nagumo reaction-diffusion system, the existence of pulses for a general class of bistable nonlinearities has been proved only recently (Hupkes and Sandstede, 2010). The existence of pulses under more general types of interactions (e.g. elastic instead of diffusive) remains an open question, as well as traveling wave propagation in higher-dimensional systems. These problems will be tackled in the PhD thesis of J.-E. Morales (advisors A. Tonnelier and G. James), which started on November 2013. J.-E. Morales has started to analyze pulse propagation in the excitable Burridge-Knopoff (BK) model, which finds applications in the context of nonlinear friction. This model includes elastic interactions between particles, and an additional difficulty linked with nonsmoothness of the (multivalued) Coulomb friction law. Using an idealized piecewise linear friction force, we have studied the propagation of a pulse wave in the discrete BK model. Using asymptotic methods, we proved the existence of a pulse wave and derived quantitative results for travelling wave properties.

6.13. Nonlinear waves in granular chains

Participants: Guillaume James, Bernard Brogliato.

Granular chains made of aligned beads interacting by contact (e.g. Newton's cradle) are widely studied in the context of impact dynamics and acoustic metamaterials. When a large number of beads are present, their dynamics can be described by infinite-dimensional differential equations, which possess a limited smoothness when unilateral Hertzian contact interactions are considered. In this context, we have developed and analyzed new reduced-order models describing nonlinear wave propagation in such systems. In the work [25] (collaboration with D. Pelinovsky, McMaster Univ.), we analyze small amplitude slowly modulated compression waves in the limit when the exponent of the Hertz force is close to unity. From a multiple scale analysis, we derive a Korteweg-de Vries equation with logarithmic nonlinearity allowing to approximate wave profiles, in particular solitary wave solutions. In the work [50] (collaboration with Y. Starosvetsky, Technion IIT), we prove existence of spatially localized nonlinear modes (breathers) in the DpS equation, an amplitude equation describing small oscillations in Newton's cradle over long time scales. For Hertz force exponents close to unity, we show that breather envelopes are well approximated by a Gaussian solution of the logarithmic nonlinear Schrödinger equation. This result is generalized to traveling localized oscillations (traveling breathers) generated by an impact in Newton's cradle (G. James, article in preparation). The existence of breathers is also analyzed in granular metamaterials consisting of hollow beads with internal masses (G. James) in collaboration with L. Liu, A. Vainchtein (Pittsburgh Univ.) and P. Kevrekidis (UMass Amherst) - article in preparation. In addition the LZB model introduced in [15] has been extensively used to numerically investigate wave phenomena in chains of aligned balls (tapered, monodisperse, anti-tapered, stepped chains). Thorough comparisons with experimental results reported in the Granular Matter literature have been made. The results are reported in the monograph [16].

6.14. Robotics

6.14.1. Lexicographic Least-Squares solver

Participants: Pierre-Brice Wieber, Dimitar Dimitrov.

We have been working on Multi-Objective Least-Squares problems with inequality constraints for the last few years, focusing especially on the Lexicographic case. The focus this year has been on nonlinear problems, in collaboration with Adrien Escande from JRL, Tsukuba, Japan. Questions concerning the second-order approximation, using a Gauss-Newton approach or considering more precise second-order information, and questions concerning the globalization scheme, trust-region and/or filter methods have been approached, but results are still preliminary.

6.14.2. Mobile manipulation by humanoid robots

Participants: Pierre-Brice Wieber, Dimitar Dimitrov, Alexander Sherikov, Jory Lafaye.

The realization of mobile manipulation by humanoid robots requires the handling of two simultaneous problems: taking care of the dynamic balance of the robot, what is usually done with Model Predictive Control (MPC) schemes, and redundant motion and force control of the whole body of the robot, what is usually done with a Quadratic Program, or a more advanced Lexicographic Least-Squares problem (see above). These two problems are usually solved in sequence: an MPC scheme first computes the necessary motion of the feet and Center of Mass (CoM) of the robot, then motion and force redundancy of the whole body of the robot is resolved. We have observed that this sequence corresponds to a lexicographic order between two objectives, feet and CoM motion first, the rest of the body after, which limits the possibility to tackle scenarios where we would like the motion of the CoM of the robot to be driven by the motion of the rest of the body of the robot, for example to catch an object with the hand. We have proposed therefore to reorganize the order between these different objectives, building on the LexLS solver presented above. The focus this year has been on non-coplanar multi-contact situations.

6.14.3. Reactive trajectory generation

Participants: Pierre-Brice Wieber, Dimitar Dimitrov, Saed Al Homsy, Matthieu Guilbert.

The goal of the ongoing collaboration with Adept Technologies is to generate near time optimal trajectories in the presence of moving obstacles in real time. Results are not public yet due to industrial constraints.

6.15. Optimization

6.15.1. Semidefinite programming and combinatorial optimization

Participant: Jérôme Malick.

We have worked with Frederic Roupin (Prof. at Paris XIII) and Nathan Krislock (Assistant Prof. at North Illinois University, USA) on the use of semidefinite programming to solve combinatorial optimization problems to optimality.

We proposed a new family of semidefinite bounds for 0-1 quadratic problems with linear or quadratic constraints [65]. We have embedded the new bounds within branch-and-bound algorithms to solve 2 standard combinatorial optimization problems to optimality.

- *Max-cut.* We developed [26] an improved bounding procedure obtained by reducing two key parameters (the target level of accuracy and the stopping tolerance of the inner Quasi-Newton engine) to zero, and iteratively adding triangle inequality cuts. We also precisely analyzed its theoretical convergence properties. We show that our method outperform the state-of-the-art solver ([66]) on the large test-problems.
- *Heaviest k-subgraph problems.* Adapting the techniques we developed for the max-cut problem, we have proposed in [60] an algorithm able to solve exactly k-cluster instances of size 160. In practice, our method works particularly fine on the most difficult instances (with a large number of vertices, small density and small k).

We have also been working on a generic online semidefinite-based solver for binary quadratic problems using the generality of [65]. Finally, a first web interface for our solvers and our data sets are available online at <http://lipn.univ-paris13.fr/BiqCrunch/>.

6.15.2. Quadratic stabilization of Benders decomposition

Participants: Jérôme Malick, Sofia Zaourar.

The Benders decomposition, a fundamental method in operation research, is known to have the inherent instability of cutting plane-based methods. The PhD thesis of Sofia Zaourar proposes a algorithmic improvement of the method inspired from the level-bundle methods of nonsmooth optimisation. We illustrate the interest of the stabilization on two classical network problems: network design problems and hub location problems. We also prove that the stabilized Benders method have the same theoretical convergence properties as the usual Benders method. An article about this research was submitted this summer.

COMMANDS Project-Team

6. New Results

6.1. Highlights of the Year

6.1.1. Optimization of running strategies based on anaerobic energy and variations of velocity

Participant: Frédéric Bonnans.

The paper [10] about running strategies proves Keller's conjecture. It was highlighted in SIAM Connect, see <http://connect.siam.org/insightful-mathematics-for-an-optimal-run/>

6.1.2. Research and transfer collaboration in aeronautics with the startup Safety Line

Participants: Frédéric Bonnans, Daphné Giorgi, Stéphan Maindrault, Pierre Martinon.

Following the meeting with the startup Safety Line at Imatch "Optimisation and Control" in october 2013, we conducted a first collaboration of six months on optimizing the fuel consumption of civil airliners. This first step successfully established the proof of concept and was validated by actual test flights in June 2014, leading to a shared patent and the development of a specific module of our software 'Bocop', included in the tool 'OptiClimb' developed at Safety Line. Future prospects include improving the numerical robustness of the current tool, as well as expanding the optimization to the cruise flight in addition to the climb phase.

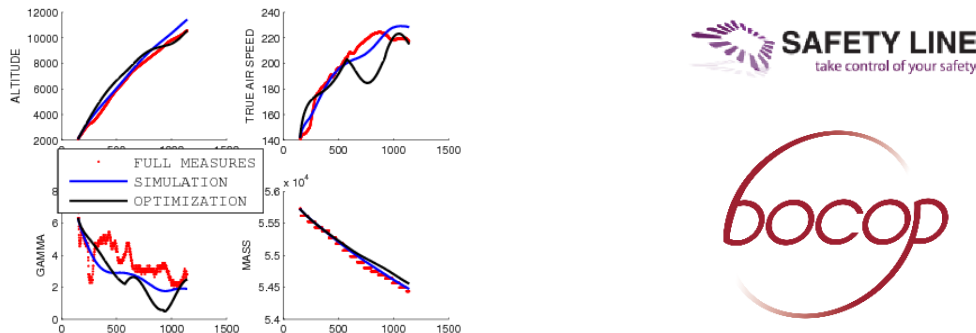

Figure 2. Plane climb phase (Boeing 737)

6.2. Second order analysis of deterministic optimal control problems

Participant: Frédéric Bonnans.

F. Bonnans, with M.S. Aronna (IMPA, Rio de Janeiro) and B.-S. Goh (Curtin U., Miri, Sarawak, Malaysia) obtained in [32] new second order necessary and sufficient optimality conditions for a class of control-affine problems with a scalar control and a scalar state constraint. These optimality conditions extend to the constrained state framework the Goh transform, which is the classical tool for obtaining an extension of the Legendre condition. We propose a shooting algorithm to solve numerically this class of problems and we provide a sufficient condition for its local convergence. We provide examples to illustrate the theory. An article by F. Bonnans, X. Dupuis (Ceremade, U. Dauphine) and L. Pfeiffer (U. Graz) has been published in the SIAM J. Control Optim. on "Second-order necessary conditions in Pontryagin form for optimal control problems" [16].

6.3. Stochastic optimization

6.3.1. Stochastic control

Participant: Frédéric Bonnans.

With J. Gianatti (U. Rosario) and F. Silva (U. Limoges) we obtained an extension of the Sakawa-Shindo algorithm (for computing a solution of the optimality system of a deterministic optimal control problem) to stochastic control problems. The paper is in progress.

6.3.2. Stochastic programming

Participants: Frédéric Bonnans, Nicolas Grebille, Faisal Wahid.

In the framework of the thesis of Nicolas Gréville, we continued our study of decomposition algorithms for a stochastic model of optimal electricity energy production. The energy production is divided in a number of zones. The idea is to constrain the energy flows between these zones, by linear feedback to the demand (which is a random variable). The coefficients of the feedback are to be optimized. Then the problem is decomposed for each zone (and can then be solved easily by a SDDP type algorithm). We obtained encouraging preliminary numerical results in a three zones problem.

Faisal Wahid developed a mixed integer program model for hydro-power producers participating in the future intra-day French Electricity Balancing Market. He has also formulated the mixed integer stochastic dynamic program model for the more general hydro-bidding under uncertainty. The objective of this model is to produce optimal offer policies in the form of supply curves under a time inhomogeneous Markov process of electricity market clearing prices.

6.3.3. Dynamic programming and error estimates for stochastic control problems with maximum cost

Participants: Athena Picarelli, Hasnaa Zidani.

The paper [14] is concerned with stochastic optimal control for a running maximum cost. A direct approach based on dynamic programming techniques is studied leading to the characterization of the value function as the unique viscosity solution of a second order Hamilton-Jacobi-Bellman (HJB) equation with an oblique derivative boundary condition. A general numerical scheme is proposed and a convergence result is provided. Error estimates are obtained for the semi-Lagrangian scheme. These results can apply to the case of lookback options in finance. Moreover, optimal control problems with maximum cost arise in the characterization of the reachable sets for a system of controlled stochastic differential equations. Some numerical simulations on examples of reachable analysis are included to illustrate our approach.

6.4. Hamilton Jacobi Bellman approach

6.4.1. Optimal feedback control of undamped wave equations by solving a HJB equation

Participants: Hasnaa Zidani, Axel Kröner.

An optimal finite-time horizon feedback control problem for (semi linear) wave equations is studied in [25]. The feedback law can be derived from the dynamic programming principle and requires to solve the evolutionary Hamilton-Jacobi-Bellman (HJB) equation. Classical discretization methods based on finite elements lead to approximated problems governed by ODEs in high dimensional space which makes infeasible the numerical resolution by HJB approach. In the present paper, an approximation based on spectral elements is used to discretize the wave equation. The effect of noise is considered and numerical simulations are presented to show the relevance of the approach.

6.4.2. Transmission conditions on interfaces for Hamilton-Jacobi-Bellman equations

Participant: Hasnaa Zidani.

The works [27], [91] deal with deterministic control problems where the dynamic and the running cost can be completely different in two (or more) complementary domains of the space \mathbb{R}^N . As a consequence, the dynamics and running cost present discontinuities at the interfaces of these domains. This leads to a complex interplay that has to be analyzed among transmission conditions to "glue" the propagation of the value function on the interfaces. Several questions arise: how to define properly the value function(s) and what is (are) the right Bellman Equation(s) associated with this problem?. In the case of a simple geometry (namely when the space \mathbb{R}^N is partitioned into two subdomains separated with an interface which is assumed to be a regular hypersurface without any connectedness requirement), [27] discuss different conditions on the hyperplane where the dynamic and the running cost are discontinuous, and the uniqueness properties of the Bellman problem are studied. In this paper we use a dynamical approach, namely instead of working with test functions, the accent is put on invariance properties of an augmented dynamics related to the integrated control system. The comparison principle is accordingly based, rather than on (semi)continuity of the Hamiltonian appearing in the Hamilton–Jacobi–Bellman equation, on some weak separation properties of this dynamics with respect to the stratification.

6.4.3. Control Problems on Stratifiable state-constraints Sets

Participants: Cristopher Hermosilla, Hasnaa Zidani.

This work deals with a state-constrained control problem. It is well known that, unless some compatibility condition between constraints and dynamics holds, the value function has not enough regularity, or can fail to be the unique constrained viscosity solution of a Hamilton–Jacobi–Bellman (HJB) equation. Here, we consider the case of a set of constraints having a strati-

ed structure. Under this circumstance, the interior of this set may be empty or disconnected, and the admissible trajectories may have the only option to stay on the boundary without possible approximation in the interior of the constraints. In such situations, the classical pointing quali-

cation hypothesis are not relevant. The discontinuous Value Function is then characterized by means of a system of HJB equations on each stratum that composes the state-constraints. This result is obtained under a local controllability assumption which is required only on the strata where some chattering phenomena could occur.

6.4.4. Constrained optimization problems in finite and infinite dimensional spaces

Participant: Cristopher Hermosilla.

We investigate in [39] convex constrained nonlinear optimization problems and optimal control with convex state constraints. For this purpose we endow the interior of constraints set with the structure of Riemannian manifold. In particular, we consider a class of Riemannian metric induced by the squared Hessian of a Legendre functions. We describe in details the geodesic curves on this manifolds and we propose a gradient-like algorithm for constrained optimization based on linear search along geodesics. We also use the Legendre change of coordinates to study the Value Function of a Mayer problem with state constraints. We provide a characterization of the Value Function for this problem as the unique viscosity solution of the Hamilton–Jacobi–Bellman equation.

6.5. Robustness of discontinuous Feedbacks

Participant: Cristopher Hermosilla.

In the paper [40] we study state-constrained discontinuous ordinary differential equations for which the corresponding vector field has a set of singularities that forms a stratification of the state domain. Existence of solutions and robustness with respect to external perturbations of the righthand term are investigated. Moreover, notions of regularity for stratifications are discussed.

6.6. Optimal control of PDEs

6.6.1. Closed-loop optimal control of PDEs

Participant: Axel Kröner.

Stabilization of Burgers equation to nonstationary trajectories A. Kröner and Sérgio S. Rodrigues (RICAM, Linz, Austria) considered in [82] using infinite-dimensional internal controls. Estimates for the dimension of the controller are derived; in the particular case of no constraint in the support of the control a better estimate is derived and the possibility of getting an analogous estimate for the general case is discussed. Numerical examples are presented illustrating the stabilizing effect of the feedback control, and suggesting that the existence of an estimate in the general case analogous to that in the particular one is plausible. In [81] the problem was considered for a finite number of internal piecewise constant controls.

Reduced-order minimum time control of advection-reaction -diffusion systems via dynamic programming Dante Kalise (RICAM, Linz, Austria) and A. Kröner considered in [79]. The authors use balanced truncation for the model reduction part and include a Luenberger observer.

A semi-Lagrangian scheme for L^p -penalized minimum time problems was considered by M. Falcone (Sapienza-Università di Roma, Italy), D. Kalise (RICAM, Austria) and A. Kröner in [78].

6.6.2. Open-loop optimal control of PDEs

Participant: Axel Kröner.

The minimum effort problem for the wave equation K. Kunisch (University of Graz, Austria) and A. Kröner considered in [80]. The problem involves L^∞ -control costs which lead to non-differentiability. Uniqueness of the solution of a regularized problem is proven and the convergence of the regularized solutions is analyzed. Further, a semi-smooth Newton method is formulated to solve the regularized problems and its superlinear convergence is shown. Numerical examples confirm the theoretical results.

6.7. Applications in deterministic optimal control

6.7.1. Contrast imaging problem in nuclear magnetic resonance

Participant: Pierre Martinon.

In collaboration with team McTAO (Sophia), we started in 2013 to study the contrast imaging problem in nuclear magnetic resonance, modeled as Mayer problem in optimal control ([58]). Using tools from the Maximum Principle and geometric control, we obtained a first synthesis of locally optimal solutions is given in the single-input case, as well as preliminary results in the bi-input case. This analysis was supported by comprehensive numerical investigations using a combination of indirect shooting (HAMPATH software) and direct method (BOCOP), with a moment-based (LMI) technique to estimate the global optimum.

These results have been extended in 2014, on the theoretical side with the classification of singular extremals ([35]), and on the numerical side with the study of a large number of spins particles subject to spatial inhomogeneities in the magnetic field.

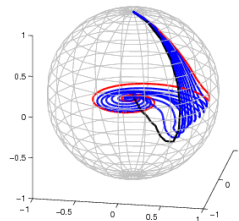

Figure 3. Contrast in quantum control for NMR - Spatial inhomogeneities

6.7.2. Optimal strokes and design for N-link microswimmer

Participant: Pierre Martinon.

Following [71], we pursued the study of the N-link swimmer, a generalization of the classical Purcell swimmer. We use the model of the Resistive Force Theory to derive the motion equation for the swimmer in a fluid with a low Reynolds number. This allows us to study and solve the optimal swimming problem in the framework of optimal control. We extend our previous study of the optimal strokes by moving to the optimal design of the swimmer. In [72] we provide an estimate of the optimal link ratio for maximal displacement, based on an expansion for small amplitudes. This theoretical result is supported by numerical simulations, that also give some insight on the type of optimal strokes depending on the constraints on the amplitude and deformation speed.

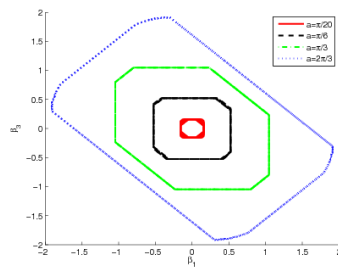

Figure 4. Phase portrait of the optimal stroke w.r.t maximal amplitude

6.7.3. Energy management for a micro-grid

Participants: Frédéric Bonnans, Daphné Giorgi, Benjamin Heymann, Stéphan Maindrault, Pierre Martinon.

We study the energy management problem for a microgrid including a diesel generator and a photovoltaic plant with a battery storage system. The objective is to minimize the total operational cost over a certain timeframe, primarily the diesel consumption, while satisfying a prescribed power load. After reformulation, the decision variables can be reduced to the charging/discharging power for the battery system. We take into account the switching cost for the diesel generator, the non-convex objective, and the long-term aging of the batteries. We solve this problem using a continuous optimal control framework, with both a direct transcription method (time discretization) and a Dynamic Programming method (Hamilton Jacobi Bellman). This project is a collaboration between team COMMANDS (Inria Saclay, France) and Centro de Energia (Universidad de Chile, Chile). A first paper is currently in preparation, while ongoing studies include comparison with the existing MILP approach, more refined battery aging models, and modeling the stochastic nature of the photovoltaic power and power load.

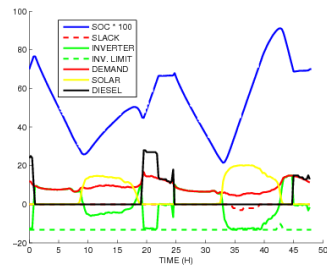

Figure 5. Microgrid management - Winter day sample case

CORIDA Team

6. New Results

6.1. Highlights of the Year

The CORIDA team organized two scientific meetings in 2014.

The first workshop, “Observers for finite and infinite dimensional systems” in April 2014, gathered people working in the field of control theory for finite and infinite dimensional systems.

Ten speakers from France, India, Portugal and Germany were invited for the second workshop, “Workshop in Mathematical Fluid Dynamics”, in November 2014.

6.2. Analysis and control of fluids and of fluid-structure interactions

In [42], we consider a two dimensional collision problem for a rigid solid immersed in a cavity filled with a perfect fluid. we investigate the asymptotic behavior of the Dirichlet energy associated to the solution of a Laplace Neumann problem as the distance between the solid and the cavity’s bottom tends to zero. We prove that the solid always reaches the cavity in finite time. The contact occurs with non zero (real shock) or null velocity (smooth landing), depending on the tangency exponent at the contact point. The proof is based on a suitable change of variables sending to infinity the cusp singularity at the contact. More precisely, the initial Laplace Neumann problem is transformed into a generalized Neumann problem set on a domain containing a horizontal strip, whose length goes to infinity as the the solid gets closer to the the cavity’s bottom.

In [43], we investigate the geometric inverse problem of determining, from the knowledge of the DtN operator of the problem, the positions and the velocities of moving rigid solids in a bounded cavity filled with a perfect fluid. We assume that the solids are small disks moving slowly. Using an integral formulation, we first derive the asymptotic expansion of the DtN map as the diameters of the disks tend to zero. Then, combining a suitable choice of exponential type data and the DORT technique (which is usually used in inverse scattering for the detection of point-like scatterers), we propose a reconstruction method for the unknown positions and velocities.

In [22], Ana Leonor Silvestre (Lisbon, Portugal) and Takéo Takahashi analyze the system fluid-rigid body in the case of where the rigid body is a ball of “small radius”. More precisely, they consider the limit system as the radius goes to zero. They recover the Navier-Stokes system with a particle following the the velocity of the fluid.

In [14], Mehdi Badra (University of Pau) and Takéo Takahashi study the feedback stabilization of a system composed by an incompressible viscous fluid and a rigid body. They stabilize the position and the velocity of the rigid body and the velocity of the fluid around a stationary state by means of a Dirichlet control, localized on the exterior boundary of the fluid domain and with values in a finite dimensional space. The first result concerns weak solutions in the two-dimensional case, for initial data close to the stationary state. The method is based on general arguments for stabilization of nonlinear parabolic systems combined with a change of variables to handle the fact that the fluid domain of the stationary state and of the stabilized solution are different. This additional difficulty leads to the assumption that the initial position of the rigid body is the position associated to the stationary state. Without this hypothesis, they work with strong solutions, and to deal with compatibility conditions at the initial time, they use finite dimensional dynamical controls. They prove again that for initial data close to the stationary state, they can stabilize the position and the velocity of the rigid body and the velocity of the fluid.

In [15], Mehdi Badra (University of Pau) and Takéo Takahashi use the Fattorini criterion (more known as the Hautus criterion) to obtain the feedback stabilizability of general linear and nonlinear parabolic systems. They then consider flow systems described by coupled Navier-Stokes type equations (such as MHD system or micropolar fluid system) to obtain the stabilizability by only considering a unique continuation property of a stationary Stokes system.

In [36], we use geometric control theory to investigate the existence and the design of optimal strokes for swimmers in Stokes of potential flows.

6.3. Frequency domain methods for the analysis and control of systems governed by PDE's

In [20], we use microlocal analysis techniques to build artificial boundary conditions for relativistic quantum dynamics.

In [11], we give a complete analysis of some new domain decomposition techniques and investigate their approximations for application in quantum physics.

In the chapter [28], we give an introduction to the modeling and the simulation of equilibrium states of Gross-Pitaevskii equations modeling Bose-Einstein condensates.

In [17], we give the basic methodology to use the software 3D GPELab for the simulation of Bose-Einstein condensates.

In [10], we develop a pseudo-spectral iterative method to compute equilibrium state of fast rotating Gross-Pitaevskii equations.

In [18], we develop a new approximation and implementation of a Magnetic-to-Electric operator for 3D-Maxwell equations.

In [13], we consider the inverse problem of determining the potential in the dynamical Schrödinger equation on the interval by the measurement on the boundary. Using the Boundary Control Method we first recover the spectrum of the problem from the observation at either left or right end points. Taking advantage of the one-dimensional configuration, we recover then the spectral function, reducing the problem to the classical one of determining the potential from the spectral function. This can be done by known methods. In order to handle more realistic situations, we also consider the case where only a finite number of eigenvalues are available and we prove the convergence of the reconstruction method as this number tends to infinity.

6.4. Observability, controllability and stabilization in the time domain

In [27], we dealt with the problem of the stabilization of a switched linear system, the feedback law being based on the optimization of a quadratic criterion. The Lyapunov function used for the design of this law defines a tight upper bound of the value of the cost for a quadratic optimization problem related to the system. Thus the obtained control law is sub-optimal.

In [19] we deal with the problem of the output stabilization of linear impulsive systems. These system are a mix of continuous and discrete-time system. An observer is synthesized and the stabilization is ensured through a feedback law which depends on the estimated state provided by the observer.

In [29], we consider the design an high gain observers for a class of continuous dynamical systems with discrete-time measurements. In this work, the measurement sampling time is considered to be variable. Moreover, the new idea of the proposed work is to synthesize an observer requiring the less knowledge as possible from the output measurements. This is done by using an updated sampling time observer. Under the global Lipschitz assumption, the asymptotic convergence of the observation error is established. As an application of this approach, an state estimation problem of an academic bioprocess is studied, and its simulation results are discussed.

In [26], we propose an MPC control scheme for a linear system with real-time constraints.

In [25] and [12], we use precise energy estimates to provide an upper bound on the error made when replacing the dynamics of an infinite dimensional conservative quantum system by a finite dimensional projection.

In [34], we give a set of sufficient conditions for approximate controllability of closed quantum systems when the dipolar approximation has to be replaced by a more realistic quadratic modeling.

In [35], we investigate the regularity of propagators of bilinear control systems and extend a celebrated negative result of Ball, Marsden and Slemrod.

In [16], we consider an infinite dimensional system modelling a boost converter connected to a load via a transmission line. The governing equations form a system coupling the telegraph partial differential equation with the ordinary differential equations modeling the converter. The coupling is given by the boundary conditions and the nonlinear controller we introduce. We design a nonlinear saturating control law using a Lyapunov function for the averaged model of the system. The main results give the well-posedness and stability properties of the obtained closed loop system.

DISCO Project-Team

6. New Results

6.1. Zero-parameter mono and multi objective methods for the tuning of controllers

The synthesis of controllers for any kind of system is the main point in Automatic Control. The traditional approach is to use a simplified model of the system to control and/or use some reformulations of the specifications to tune an often efficient but suboptimal controller. In a more and more competitive industrial context, the design of high performances controllers has emerged as a crucial point to enhance the global productivity. However, the design of optimal controllers supposes the solution of non-convex and non-differentiable optimization problems, for which deterministic and (often) local search algorithm fail in the solution. In this work, Particle Swarm Optimization is used to solve the problem, and tested to define some controllers for a magnetic levitation. The use of standard settings and penalization terms leads to a zero-parameter and reformulation free method. Results are much than satisfactory and show that Evolutionary Computation could be of great interest in the Automatic Control field.

6.2. Fixed-structure H_∞ synthesis for multiple plants

This work proposes an efficient evolutionary approach to the fixed-order and structured H_∞ control design problem extended to the multiple plants case. By testing it on the classical example of a flexible plant, this evolutionary approach proves to be very efficient compared with other recent tools, especially in the case of a high number of plants; it can then be considered as an interesting alternative for such problems.

6.3. Fixed-Structure Mu-Synthesis

This work proposes to shed a new light on the Mu-synthesis problem using the differential evolution algorithm. This algorithm allows optimizing simultaneously the structured controller and the dynamic (or static) D-scalings, which leads to robust performance controllers. This method has been applied successfully to a classical flexible plant control problem. After a comparison between the evolutionary approach and the non-smooth optimization one has envisaged proving the high potential of the proposed method.

6.4. Algebraic Analysis Approach to Linear Functional Systems

6.4.1. Serre's reduction problem

The purpose of this work is to study the connections existing between Serre's reduction of linear functional systems - which aims at finding an equivalent system defined by fewer equations and fewer unknowns - and the decomposition problem - which aims at finding an equivalent system having a diagonal block structure - in which one of the diagonal blocks is assumed to be the identity matrix. In order to do that, in [62], we further develop results on Serre's reduction problem and on the decomposition problem. Finally, we show how these techniques can be used to analyze the decomposability problem of standard linear systems of partial differential equations studied in hydrodynamics such as Stokes equations, Oseen equations and the movement of an incompressible fluid rotating with a small velocity around a vertical axis.

6.4.2. A spectral sequence central in the behaviour approach

Within the algebraic analysis approach to multidimensional systems, the behavioural approach developed by J. C. Willems can be understood as a dual approach to the module-theoretic approach. This duality is exact when the signal space is an injective cogenerator module over the ring of differential operators. In particular, the obstruction to the existence of a parametrization of a multidimensional system is characterized by the existence of autonomous elements of the multidimensional system. In [52], we consider the case of a general signal space and investigate the connection between the algebraic properties of the differential module defining the multidimensional system and the obstruction to the existence of parametrizations of the multidimensional system. To do so, we investigate a certain Grothendieck spectral sequence connecting the obstructions to the existence of parametrizations to the obstructions to the differential module - defining the multidimensional system - to be torsion-free, reflexive ...projective.

6.4.3. Restrictions of n -D systems and inverse images of D -modules

The problem of characterizing the restriction of the solutions of a n -D system to a subvector space of \mathbb{R}^n has recently been investigated in the literature of multidimensional systems theory. For instance, this problem plays an important role in the stability analysis and in stabilization problems of multidimensional systems. In this work, we characterize the restriction of a n -D behaviour to an algebraic or analytic submanifold of \mathbb{R}^n . In [51], within the algebraic analysis approach to multidimensional systems, we show that the restriction of a n -D behaviour to an algebraic or analytic submanifold can be characterized in terms of the inverse image of the differential module defining the behaviour. Explicit characterization of inverse images of differential modules is investigated. Finally, we explain Kashiwara's extension of the Cauchy-Kowalevsky theorem for general n -D behaviours and non-characteristic algebraic or analytic submanifolds.

6.4.4. Artstein's transformation of linear time-delay systems

Artstein's classical results show that a linear first-order differential time-delay system with delays in the input is equivalent to a linear first-order differential system without delays thanks to an invertible transform which includes integral and delay operators. Within a constructive algebraic approach, we show how Artstein's reduction can be found again and generalized as a particular isomorphism problem between the finitely presented modules defined by the two above linear systems over the ring of integro-differential time-delay operators. Moreover, we show that Artstein's reduction can be obtained in an automatic way by means of symbolic computation, and thus can be implemented in computer algebra systems.

6.5. New Techniques for Robust Control of Linear Infinite-Dimensional Systems

6.5.1. Robust stabilization of a flexible rod moving in rotation and translation

We develop a hierarchy of models for a flexible rod moving in rotation and translation from a nonlinear partial differential model (generalization of the Euler-Bernoulli equation) to a linear partial differential equation and finite-dimensional models via approximations. We study the stability of those models as well as their robust stabilizations. This work is an extension of the results obtained in [61]. This work will be pursued within the framework of a CIFRE PhD thesis developed in collaboration with SAGEM (2015).

6.5.2. Noncommutative geometric approach to infinite-dimensional systems theory:

This new field of research aims at showing that noncommutative geometric structures such as connections and curvatures exist on internally stabilizable infinite-dimensional linear systems and on their stabilizing controllers. To see this new geometry, using the noncommutative geometry developed by Connes, we have to replace the standard differential calculus by the quantized differential calculus and classical vector bundles by projective modules. In [50], we give an explicit description of the connections on an internally stabilizable system and on its stabilizing controllers in terms of the projectors of the closed-loop system classically used in robust control. Their curvatures are explicitly computed. These connections aim at studying the variations

of the signals in the closed-loop system in response to a disturbance or a change of the reference. The study of these connections are useful to understand how techniques of (noncommutative) differential geometry can be used in the study of H^∞ control theory.

6.5.3. A fractional ideal approach to the robust regulation problem

We show how fractional ideal techniques developed in [8] can be used to obtain a general formulation of the internal model principle for stabilizable infinite-dimensional SISO plants which do not necessarily admit coprime factorization. This result is then used to obtain necessary and sufficient conditions for the robust regulation problem. In particular, we find again all the standard results obtained in the literature.

6.5.4. Robust control as an application to the homological perturbation lemma:

Within the lattice approach to transfer matrices developed in [8], we have recently shown how standard results on robust control can be obtained in a unified way and generalized when interpreted as a particular case of the so-called Homological Perturbation Lemma. This lemma plays a significant role in algebraic topology, homological algebra, algebraic and differential geometry, computer algebra, ... Our results show that it is also central to robust control theory for infinite-dimensional linear systems.

6.6. Set invariance for discrete-time delay systems

We studied the existence of positively invariant sets for linear delay-difference equations. In particular, we regarded two strong stability notions: robust (with respect to delay parameter) asymptotic stability for the discrete-time case and delay-independent stability for the continuous-time case. The correlation between these stability concepts is also considered. Furthermore, for the delay-difference equations with two delay parameters, we provided a computationally efficient numerical routine which is necessary to guarantee the existence of contractive sets of Lyapunov–Razumikhin type. This condition also appears to be necessary and sufficient for the delay-independent stability and sufficient for the robust asymptotic stability. The results are published in [25].

We proposed a new perspective on the structural properties of invariant sets for time delay systems via set factorization. This novel perspective describes, in a unified framework, different existing notions of invariant sets [60]. Additionally, it is shown that the (possible non-minimal) state space representation is a key element in the description of low complexity invariant sets.

6.7. Low complexity constrained control

On one side, we proposed an explicit (piecewise affine feedback) control obtained via interpolation for constrained linear systems [23]. On another side, we studied the Linear Constrained Regulation problem for Continuous-Time Systems in the presence of non-convex constraints [32]. This might prove to be useful for the multi-agent dynamical systems operating under collision avoidance constraints.

6.8. Fault detection based on set theoretic methods and connexions with fault tolerant control

We proposed a set-theoretic fault detection mechanism for multisensor systems with a classification of possible functioning according to the use in the feedback mechanism. The healthy, faulty and under-recovery class are characterized via set descriptions in the residual space and as such can be monitored via on-line mechanisms [26]. Furthermore, the robust detection has been enhanced with an interval observer mechanism for the monitoring during the transients [28].

6.9. Interval Observer

We made several progresses in the domain of the construction of state estimators called interval observers.

- 1) In [16], we have shown how interval observers can be constructed for nonlinear (and not Lipschitz) systems possessing a special triangular system. These systems are not cooperative and not globally Lipschitz and have a rather general structure which may result from a change of coordinates or an output injection. Besides, under additional assumptions, input to state stability (ISS) properties are derived. We illustrated the constructions by designing a framer and an ISS interval observer for two models of bioreactors.
- 2) The contributions [17] and [18] present major results for the design of interval observers for discrete-time systems. In [18], coordinate transformations which change an arbitrary linear discrete-time system into a positive one and general nonlinear designs of interval observers for nonlinear systems (satisfying a restrictive stability assumption) are proposed. In [17], it is explained how two classical Luenberger observers can be used, (even in the absence of the positivity property of the studied system or the error equations) as interval observer, provided two appropriate outputs, which compose the lower and the upper bound of the interval observer, are selected.
- 3) In [33], we present a new type of interval observers for nonlinear systems that are affine in the unmeasured part of the state. They are composed of two copies of classical observers and upper and lower bounds which are designed by taking advantage of positivity properties of the error equations when written in appropriate coordinates.

6.10. Reduction model approach: new advances

We solved several distinct problems entailing to the celebrated reduction model approach. Let us recall that this technique makes it possible to stabilize systems with arbitrarily large pointwise or distributed delays in the input.

- 1) In [46], solutions to the problem of globally exponentially stabilizing linear systems with an arbitrarily long pointwise delay with sampled feedbacks are presented. The main result of a contribution by F. Mazenc and D. Normand-Cyrot is recalled and compared with other results available in the literature.
- 2) We considered in [41] a stabilization problem for continuous-time linear systems with discrete-time measurements and a sampled input with a pointwise constant delay. In a first step, we constructed a continuous-discrete observer which converges when the maximum time interval between two consecutive measurements is sufficiently small. We also constructed a dynamic output feedback through a technique which is strongly reminiscent of the reduction model approach. It stabilizes the system when the maximal time between two consecutive sampling instants is sufficiently small. No limitation on the size of the delay was imposed.
- 3) In [43], we studied a general class of nonlinear systems with input delays of arbitrary size. We adapted the reduction model approach to prove local asymptotic stability of the closed loop input delayed systems, using feedbacks that may be nonlinear. We determined estimates of the basins of attraction for the closed loop systems using Lyapunov-Krasovskii functionals.
- 4) The contribution [21] is devoted to stabilization problems for time-varying linear systems with constant input delays. The reduction model approach we proposed ensures a robustness property (input-to-state stability) with respect to additive uncertainties, under arbitrarily long delays. It applies to rapidly time-varying systems, and gives a lower bound on the admissible rapidness parameters. We also covered slowly time-varying systems, including upper bounds on the allowable slowness parameters. We illustrated our work using a pendulum model.

6.11. Nonlinear systems with delay

- 1) In [45], we developed a new technique for stability analysis for nonlinear dynamical systems with delays and possible discontinuities. In contrast with Lyapunov based approaches, the trajectory based approach we proposed involves verifying certain inequalities along solutions of auxiliary systems. It applies to a wide range of systems, notably time-varying systems with time-varying delay, ODE coupled with difference equations, and networked control systems with delay. It relies on the input-to-state stability notion, and yields input-to-state stability with respect to uncertainty.

2) In [39], to address various types of delays including the neutral-type arising in dynamical networks, we dealt with coupled delay differential and continuous-time difference equations and proposed stability and robustness criteria. In these criteria, differential equation parts do not necessarily exhibit unbounded dissipation rate. Subsystems described by differential equations are not required to be input-to-state stable either. No assumptions on network topology are made. To handle such a general case, we construct explicit Lyapunov-type functionals. We established stability and robustness of the overall networks.

3) In [22], [42] and [44], stability results for several families of systems with delay are established. The key ingredient of these contributions is the use of comparison systems of a new type, the theory of the positive systems and linear Lyapunov functionals. We provided robustness of the stability with respect to multiplicative uncertainty in the vector fields. We allowed cases where the delay may be unknown, and where the vector fields defining the systems are not necessarily bounded. We illustrate our work using a chain of integrators and other examples.

6.12. Strictification

In [40], the problem of stabilizing rigid-body attitude dynamics in the presence of pointwise time-delay for the input torque is considered. A quaternion-based linear state feedback controller is shown to achieve local stability in addition to the characterization of sufficient condition that depends only on the magnitude of the initial angular rates. More specifically, no restrictions are imposed on the body initial orientation which is a significant contrast with other results from recent literature that adopt three-dimensional representations for the attitude kinematics. Using the quaternion-based linear feedback structure, the closed-loop system is shown to never admit the possibility for finite-time escapes. While the actual magnitude of the time-delay can be unknown, an upper bound on the delay is assumed to be known. The proof relies on the construction of a functional which does not belong to the family of the strict Lyapunov-Krasovskii functionals, but shares important features with the functionals of this family. The stability conditions and results are illustrated through numerical simulations.

6.13. Stability analysis of fractional and classical neutral systems with commensurate delays

Fractional and classical neutral systems with commensurate delays have chains of poles asymptotic to vertical lines (see [66] for classical systems). The delicate case where system have some chains of poles asymptotic to the imaginary axis is interesting as the absence of poles in the open left half-plane does not guarantee the H_∞ -stability of the system.

Stability analysis of classical or fractional neutral systems with one single chain of poles asymptotic to the imaginary axis has been investigated in [88], [70], [2], [69], where the asymptotic location of poles of neutral chains was given and necessary and sufficient conditions for H_∞ -stability were derived.

We have performed a full analysis of classical and fractional systems with multiple chains of poles approaching a set of points on the imaginary axis. Moreover, a unified method to analyze the stability of fractional and classical systems has been derived.

6.14. Stabilization of fractional neutral systems with commensurate delays

We consider strictly proper fractional neutral systems with one delay and one chain of poles asymptotic to the imaginary axis including the case where this chain may approach the axis from the right side. Thus the system may possess infinitely many poles in the right half-plane. For these systems, a Youla-Kučera parametrization regarding H_∞ -stability of all stabilizing controllers has been obtained in [59]. Having in mind the robustness of the closed-loop relative to parameter uncertainties, we wish to find controllers which are able to provide a closed-loop free of chain of poles asymptotic to the imaginary axis. However, we prove that a large class of realizable stabilizing controllers cannot achieve this. [47].

6.15. Stabilization of MISO fractional systems with I/O delays

In order to yield the set of all the stabilizing controllers of a class of MISO fractional systems with delays by mean of Youla-Kučera parametrization regarding H_∞ -stability, we are interested in determining coprime factorizations of the transfer function. Explicit expressions of left coprime factorizations and left Bézout factors have been derived in [85]. Explicit expressions of right coprime factorizations and right Bézout factors for some classes of systems have also been derived in [86]. Recently, we obtain right factors for a more general class of systems. Furthermore, we present these right factors in the minimal form, i.e. factors with the minimal number of coefficients to be determined and with the lowest degree. We also obtain left factors in the minimal form.

6.16. Modeling and control of Acute Myeloid Leukemia

Starting from a PDE model of hematopoiesis given in [64], we have derived several models of healthy or cancer cell dynamics in hematopoiesis and performed several stability analyses.

We have proposed in [58] a new mathematical model of the cell dynamics in Acute Myeloid Leukemia (AML) which takes into account the four different phases of the proliferating compartment as well the fast self-renewal phenomenon frequently observed in AML. As was the case in [58] this model is transformed into a distributed delay system and was analyzed here with input-output techniques. Local stability conditions for an equilibrium point of interest are derived in terms of a set of inequalities involving the parameters of the mathematical model.

We have also studied a coupled delay model for healthy and cancer cell dynamics in Acute Myeloid Leukemia consisting of two stages of maturation for cancer cells and three stages of maturation for healthy cells. For a particular healthy equilibrium point, locally stability conditions involving the parameters of the mathematical model have been obtained [30], [31].

We have performed in [29] a stability analysis of both the PDE model of healthy hematopoiesis and a coupled PDE model of healthy and cancer cell dynamics. The stability conditions obtained here in the time domain strengthen the idea that fast self-renewal plays an important role in AML.

A time-domain stability analysis by means of Lyapunov-Krasovskii functionals has been performed on the delay system modeling healthy hematopoiesis for a strictly positive equilibrium point of interest.

6.17. Algebraic geometry techniques for polynomial systems

6.17.1. Testing the structural stability of N -d discrete linear systems

The goal of this work is to propose new computer algebra based methods for testing the structural stability of N -d discrete linear systems. Recall that a discrete linear system given by its transfer function $G(z_1, \dots, z_n) = N(z_1, \dots, z_n)/D(z_1, \dots, z_n)$ is said to be stable if and only if the denominator $D(z_1, \dots, z_n)$ is devoid from zero inside the unit complex poly-disc. This fundamental problem in the analysis of N -d systems has been extensively studied these last decades. At the end of the seventies, DeCarlo et al [77] show that testing the previous condition is equivalent to testing the existence of complex zeros on each face of the poly-disc i.e. $D(1, \dots, z_i, \dots, 1)$ for $i = 1 \dots n$ as well as testing the existence of complex zero on the poly-circle i.e. the zeros of $D(z_1, \dots, z_n)$ when $|z_1| = \dots = |z_n| = 1$.

Starting from the conditions of DeCarlo et al, we propose a new approach that transform the last condition, that is, the non-existence of complex zeros on the unit poly-circle to a condition on the existence of real solutions inside a region of R^n . More precisely we propose two type of transformations. The first one reduces the problem to looking for real solutions inside the unit box while the second one reduces the problem to looking for real solutions in the whole space R^n . In order to check the existence of real solutions, we use classical computer algebra algorithms for solving systems of polynomial equations. In the case of one or two variables, the appearing systems are generally zero-dimensional. To count or locate the real solutions of such systems, we compute a rational univariate representation [95], that is a one to one mapping between the solutions of the

system and the roots of a univariate polynomial, thus the problem is reduced to a univariate problem. When the number of variables is larger than two, the systems that stem from the conditions above are no longer zero-dimensional. In such case, we use critical points method that allow to compute solutions in each real connected component of the zeros of the systems [65].

We implemented the previous approach on maple using the external library *Raglib* [63] which provides routines for testing the existence of real solutions of an algebraic system. Preliminary tests show the relevance of our approach.

This work is supported by the ANR MSDOS grant.

6.17.2. Efficient algorithms for solving bivariate algebraic systems

This work addresses the problem of solving a bivariate algebraic system (i.e computing certified numerical approximation of the solutions) via the computation of a rational univariate representation. Such a representation is useful since it allows to turn many queries on the system into queries on univariate polynomials. Given two coprime polynomials P and Q in $Z[x, y]$ of degree bounded by d and bitsize bounded by τ we present new algorithms for computing rational univariate representation of the system $\{P, Q\}$ and from this representation, isolating the real solutions of $\{P, Q\}$. The cost analysis of these algorithms show that they have a worst-case bit complexity in $sOB(d^6 + d^5\tau)$ which improves by a factor d the state-of-the-art complexity.

GECO Project-Team

6. New Results

6.1. Highlights of the Year

We organized a thematic trimester on “Geometry, analysis and dynamics on sub-Riemannian manifolds” at the Institut Henri Poincaré (IHP), including 4 workshops, 4 research courses, 8 thematic days, several seminars. We also organized an associated school at CIRM with 4 introductory courses. The web pages of the events are:

<http://www.cmap.polytechnique.fr/subriemannian/>

<http://www.cmap.polytechnique.fr/subriemannian/cirm/>

6.2. New results: geometric control

Let us list some new results in sub-Riemannian geometry and hypoelliptic diffusion obtained by GECO’s members.

- The article [14] presents simple controls that generate motion in the direction of high order Lie brackets. Whereas the naive use of piecewise constant controls requires the number of switchings to grow exponentially with the length of the bracket, we show that such motion is possible with sinusoidal controls whose sum of frequencies equals the length of the bracket. This work is closely related and motivated by the study of the complexity of sub-Riemannian geodesics for generic regular distributions, i.e., whose derived flag has maximal growth vector. Of particular interest is the approximation of curves transversal to the distribution by admissible curves. We also present a surprising example that shows that it is possible to simultaneously kill higher moments without increasing the number of self-intersections of the base curve.
- The curvature discussed in [18] is a rather far going generalization of the Riemann sectional curvature. We define it for a wide class of optimal control problems: a unified framework including geometric structures such as Riemannian, sub-Riemannian, Finsler and sub-Finsler structures; a special attention is paid to the sub-Riemannian (or Carnot-Carathéodory) metric spaces. Our construction of the curvature is direct and naive, and it is similar to the original approach by Riemann. Surprisingly, it works in a very general setting and, in particular, for all sub-Riemannian spaces.
- In [19] we prove sectional and Ricci-type comparison theorems for the existence of conjugate points along sub-Riemannian geodesics. In order to do that, we regard sub-Riemannian structures as a special kind of variational problems. In this setting, we identify a class of models, namely linear quadratic optimal control systems, that play the role of the constant curvature spaces. As an application, we prove a version of sub-Riemannian Bonnet–Myers theorem and we obtain some new results on conjugate points for 3D left-invariant sub-Riemannian structures.
- In the study of conjugate times in sub-Riemannian geometry, linear quadratic optimal control problems show up as model cases. In [1] we consider a dynamical system with a constant, quadratic Hamiltonian h , and we characterize the number of conjugate times in terms of the spectrum of the Hamiltonian vector field H . We prove the following dichotomy: the number of conjugate times is identically zero or grows to infinity. The latter case occurs if and only if H has at least one Jordan block of odd dimension corresponding to a purely imaginary eigenvalue. As a byproduct, we obtain bounds from below on the number of conjugate times contained in an interval in terms of the spectrum of H .

- A 3D almost-Riemannian manifold is a generalized Riemannian manifold defined locally by 3 vector fields that play the role of an orthonormal frame, but could become collinear on some set called the singular set. Under the Hormander condition, a 3D almost-Riemannian structure still has a metric space structure, whose topology is compatible with the original topology of the manifold. Almost-Riemannian manifolds were deeply studied in dimension 2. In [21] we start the study of the 3D case which appear to be richer with respect to the 2D case, due to the presence of abnormal extremals which define a field of directions on the singular set. We study the type of singularities of the metric that could appear generically, we construct local normal forms and we study abnormal extremals. We then study the nilpotent approximation and the structure of the corresponding small spheres. We finally give some preliminary results about heat diffusion on such manifolds.
- In [22] we study spectral properties of the Laplace-Beltrami operator on two relevant almost-Riemannian manifolds, namely the Grushin structures on the cylinder and on the sphere. As for general almost-Riemannian structures (under certain technical hypothesis), the singular set acts as a barrier for the evolution of the heat and of a quantum particle, although geodesics can cross it. This is a consequence of the self-adjointness of the Laplace-Beltrami operator on each connected component of the manifolds without the singular set. We get explicit descriptions of the spectrum, of the eigenfunctions and their properties. In particular in both cases we get a Weyl law with dominant term $E \log E$. We then study the effect of an Aharonov-Bohm non-apophantic magnetic potential that has a drastic effect on the spectral properties. Other generalized Riemannian structures including conic and anti-conic type manifolds are also studied. In this case, the Aharonov-Bohm magnetic potential may affect the self-adjointness of the Laplace-Beltrami operator.
- In [28] we investigate the number of geodesics between two points p and q on a contact sub-Riemannian manifold M . We show that the count of geodesics on M is controlled by the count on its nilpotent approximation at p (a contact Carnot group). For contact Carnot groups we give sharp bounds for a generic point q . Removing the genericity condition for q , geodesics might appear in families and we prove a similar statement for their topology. We study these families, and in particular we focus on the unexpected appearance of isometrically non-equivalent geodesics: families on which the action of isometries is not transitive. We apply the previous study to contact sub-Riemannian manifolds: we prove that for any given point $p \in M$ there is a sequence of points p_n such that $p_n \rightarrow p$ and that the number of geodesics between p and p_n grows unbounded (moreover these geodesics have the property of being contained in a small neighborhood of p).

New results on automatic control and motion planning for various type of applicative domains are the following.

- [8] is devoted to the problem of model-based prognostics for a Waste Water Treatment Plant (WWTP). Our aim is to predict degradation of certain parameters in the process, in order to anticipate malfunctions and to schedule maintenance. It turns out that a WWTP, together with the possible malfunction, has a specific structure: mostly, the malfunction appears in the model as an unknown input function. The process is observable whatever this unknown input is, and the unknown input can itself be identified through the observations. Due to this property, our method does not require any assumption of the type "slow dynamics degradation", as is usually assumed in ordinary prognostic methods. Our system being unknown-input observable, standard observer-based methods are enough to solve prognostic problems. Simulation results are shown for a typical WWTP.
- In [9] we study the problem of controlling an unmanned aerial vehicle (UAV) to provide a target supervision and/or to provide convoy protection to ground vehicles. We first present a control strategy based upon a Lyapunov-LaSalle stabilization method to provide supervision of a stationary target. The UAV is expected to join a pre-designed admissible circular trajectory around the target which is itself a fixed point in the space. Our strategy is presented for both high altitude long endurance (HALE) and medium altitude long endurance (MALE) types of UAVs.
- In [12] we study how a particular spatial structure with a buffer impacts the number of equilibria and their stability in the chemostat model. We show that the occurrence of a buffer can allow a

species to setup or on the opposite to go to extinction, depending on the characteristics of the buffer. For non-monotonic response function, we characterize the buffered configurations that make the chemostat dynamics globally asymptotically stable, while this is not possible with single, serial or parallel vessels of the same total volume and input flow. These results are illustrated with the Haldane kinetic function.

- In [15] and [25] we present new results on the path planning problem in the case study of the car with trailers. We formulate the problem in the framework of optimal nonholonomic interpolation and we use standard techniques of nonlinear optimal control theory for deriving hyperelliptic signals as controls for driving the system in an optimal way. The hyperelliptic curves contain as many loops as the number of nonzero Lie brackets generated by the system. We compare the hyperelliptic signals with the ordinary Lissajous-like signals that appear in the literature, we conclude that the former have better performance.
- In [27] we consider affine-control systems, i.e., systems in the form $\dot{q}(t) = f_0(q(t)) + \sum_{i=1}^m u_i(t)f_i(q(t))$. Here, the point q belongs to a smooth manifold M , the f_i 's are smooth vector fields on M . This type of system appears in many applications for mechanical systems, quantum control, microswimmers, neuro-geometry of vision...

We conclude the section by mentioning the book [17] that we edited, collecting some papers in honour of Andrei A. Agrachev for his 60th birthday. The book contains new results on sub-Riemannian geometry and more generally on the geometric theory of control.

6.3. New results: quantum control

New results have been obtained for the control of the bilinear Schrödinger equation.

- In [2] we present a sufficient condition for approximate controllability of the bilinear discrete-spectrum Schrödinger equation in the multi-input case. The controllability result extends to simultaneous controllability, approximate controllability in H^s , and tracking in modulus. The sufficient condition is more general than those present in the literature even in the single-input case and allows the spectrum of the uncontrolled operator to be very degenerate (e.g. to have multiple eigenvalues or equal gaps among different pairs of eigenvalues). We apply the general result to a rotating polar linear molecule, driven by three orthogonal external fields. A remarkable property of this model is the presence of infinitely many degeneracies and resonances in the spectrum.
- In [5] we consider the minimum time population transfer problem for a two level quantum system driven by two external fields with bounded amplitude. The controls are modeled as real functions and we do not use the Rotating Wave Approximation. After projection on the Bloch sphere, we treat the time-optimal control problem with techniques of optimal synthesis on 2D manifolds. Based on the Pontryagin Maximum Principle, we characterize a restricted set of candidate optimal trajectories. Properties on this set, crucial for complete optimal synthesis, are illustrated by numerical simulations. Furthermore, when the two controls have the same bound and this bound is small with respect to the difference of the two energy levels, we get a complete optimal synthesis up to a small neighborhood of the antipodal point of the initial condition.
- In [11] we investigate the controllability of quantum electrons trapped in a two-dimensional device, typically a metal oxide semiconductor (MOS) field-effect transistor. The problem is modeled by the Schrödinger equation in a bounded domain coupled to the Poisson equation for the electrical potential. The controller acts on the system through the boundary condition on the potential, on a part of the boundary modeling the gate. We prove that, generically with respect to the shape of the domain and boundary conditions on the gate, the device is controllable. We also consider control properties of a more realistic nonlinear version of the device, taking into account the self-consistent electrostatic Poisson potential.
- In [29] we prove the approximate controllability of a bilinear Schrödinger equation modelling a two trapped ions system. A new spectral decoupling technique is introduced, which allows to analyze the controllability of the infinite-dimensional system through finite-dimensional considerations.

6.4. New results: neurophysiology

- [3] presents a semidiscrete alternative to the theory of neurogeometry of vision, due to Citti, Petitot, and Sarti. We propose a new ingredient, namely, working on the group of translations and discrete rotations $SE(2, N)$. The theoretical side of our study relates the stochastic nature of the problem with the Moore group structure of $SE(2, N)$. Harmonic analysis over this group leads to very simple finite dimensional reductions. We then apply these ideas to the inpainting problem which is reduced to the integration of a completely parallelizable finite set of Mathieu-type diffusions (indexed by the dual of $SE(2, N)$ in place of the points of the Fourier plane, which is a drastic reduction). The integration of the the Mathieu equations can be performed by standard numerical methods for elliptic diffusions and leads to a very simple and efficient class of inpainting algorithms. We illustrate the performances of the method on a series of deeply corrupted images.
- In [4] and [7] we consider the problem of minimizing $\int_0^l \sqrt{\xi^2 + K(s)^2} ds$ for a planar curve having fixed initial and final positions and directions. The total length l is free. Here s is the arclength parameter, $K(s)$ is the curvature of the curve and $\xi > 0$ is a fixed constant. This problem comes from a model of geometry of vision due to Petitot, Citti and Sarti. We study existence of local and global minimizers for this problem. In [7] we characterize sub-Riemannian geodesics and the range of the exponential map. In [4] we prove that if for a certain choice of boundary conditions there is no global minimizer, then there is neither a local minimizer nor a geodesic. We finally give properties of the set of boundary conditions for which there exists a solution to the problem.

6.5. New results: switched systems

- In [6] we consider a family of linear control systems $\dot{x} = Ax + \alpha Bu$ on \mathbb{R}^d , where α belongs to a given class of persistently exciting signals. We seek maximal α -uniform stabilization and destabilization by means of linear feedbacks $u = Kx$. We extend previous results obtained for bidimensional single-input linear control systems to the general case as follows: if there exists at least one K such that the Lie algebra generated by A and BK is equal to the set of all $d \times d$ matrices, then the maximal rate of convergence of (A, B) is equal to the maximal rate of divergence of (A, B) . We also provide more precise results in the general single-input case, where the above result is obtained under the simpler assumption of controllability of the pair (A, B) .
- The paper [10] considers the stabilization to the origin of a persistently excited linear system by means of a linear state feedback, where we suppose that the feedback law is not applied instantaneously, but after a certain positive delay (not necessarily constant). The main result is that, under certain spectral hypotheses on the linear system, stabilization by means of a linear delayed feedback is indeed possible, generalizing a previous result already known for non-delayed feedback laws.
- In [16] and [26] we give a collection of converse Lyapunov–Krasovskii theorems for uncertain retarded differential equations. We show that the existence of a weakly degenerate Lyapunov–Krasovskii functional is a necessary and sufficient condition for the global exponential stability of the linear retarded functional differential equations. This is carried out using the switched system transformation approach.
- Consider a continuous-time linear switched system on \mathbb{R}^n associated with a compact convex set of matrices. When it is irreducible and its largest Lyapunov exponent is zero there always exists a Barabanov norm associated with the system. In [23] we deal with two types of issues: (a) properties of Barabanov norms such as uniqueness up to homogeneity and strict convexity; (b) asymptotic behaviour of the extremal solutions of the linear switched system. Regarding Issue (a), we provide partial answers and propose four related open problems. As for Issue (b), we establish, when $n = 3$, a Poincaré–Bendixson theorem under a regularity assumption on the set of matrices. We then revisit a noteworthy result of N.E. Barabanov describing the asymptotic behaviour of linear switched system on \mathbb{R}^3 associated with a pair of Hurwitz matrices $\{A, A + bc^T\}$. After pointing out a fatal gap in Barabanov’s proof we partially recover his result by alternative arguments.

- In [24] we address the exponential stability of a system of transport equations with intermittent damping on a network of $N \geq 2$ circles intersecting at a single point O . The N equations are coupled through a linear mixing of their values at O , described by a matrix M . The activity of the intermittent damping is determined by persistently exciting signals, all belonging to a fixed class. The main result is that, under suitable hypotheses on M and on the rationality of the ratios between the lengths of the circles, such a system is exponentially stable, uniformly with respect to the persistently exciting signals. The proof relies on an explicit formula for the solutions of this system, which allows one to track down the effects of the intermittent damping.

I4S Project-Team

6. New Results

6.1. Highlights of the Year

The team organized the 7th European Workshop on SHM in Nantes in July 2014 (<http://ewshm2014.com>).

6.2. Analysis and control of systems

6.2.1. *Optimal vibration damping of large structures*

Participant: Dominique Siegert.

This paper deals with the theoretical and experimental analysis of magnetically tuned mass dampers, applied to the vibration damping of large structures of civil engineering interest. Two devices are analysed, for which both the frequency tuning ratio and the damping coefficient can be easily and finely calibrated. They are applied for the damping of the vibrations along two natural modes of a mock-up of a bridge under construction. An original analysis, based on the Maxwell receding image method, is developed for estimating the drag force arising inside the damping devices. It also takes into account self inductance effects, yielding a complex nonlinear dependence of the drag force on the velocity. The analysis highlights the range of velocities for which the drag force can be assumed of viscous type, and shows its dependence on the involved geometrical parameters of the dampers. The model outcomes are then compared to the corresponding experimental calibration curves. A dynamic model of the controlled structure equipped with the two damping devices is presented, and used for the development of original optimization expressions and for determining the corresponding maximum achievable damping. Finally, several experimental results are presented, concerning both the free and harmonically forced vibration damping of the bridge mock-up, and compared to the corresponding theoretical predictions. The experimental results reveal that the maximum theoretical damping performance can be achieved, when both the tuning frequencies and damping coefficients of each device are finely calibrated according to the optimization expressions [13], [44].

6.2.2. *Particle filtering techniques for monitoring of structures*

Participant: Laurent Mevel.

The focus of this paper is Bayesian modal parameter recursive estimation based on an interacting Kalman filter algorithm with decoupled distributions for frequency and damping. Interacting Kalman filter is a combination of two widely used Bayesian estimation methods: the particle filter and the Kalman filter. Some sensitivity analysis techniques are also proposed in order to deduce a recursive estimate of modal parameters from the estimates of the damping/stiffness coefficients [28].

6.2.3. *Uncertainty quantification*

Participants: Michael Doehler, Laurent Mevel.

For applications as Operational Modal Analysis (OMA) of vibrating structures, an output-only LTI system with state and measurement noise can be identified using subspace methods. While these identification techniques have been very suitable for the identification of such mechanical, aeronautical or civil structures, covariance expressions of the estimates of the system matrices are difficult to obtain and theoretical results from literature are hard to implement for output-only systems with unknown noise properties in practice. Moreover, the model order of the underlying system is generally unknown and due to noise and model errors, usual statistical criteria cannot be used. Instead, the system is estimated at multiple model orders and some GUI driven stabilization diagram containing the resulting modal parameters is used by the structural engineer. Then, the covariance of the estimates at these different model orders is an important information for the engineer, which, however, would be computationally expensive to obtain with the existing tools. Recently a fast multi-order version of the stochastic subspace identification approach has been proposed, which is based on the use of the QR decomposition of the observability matrix at the largest model order. In this paper, the corresponding covariance expressions for the system matrix estimates at multiple model orders are derived and successfully applied on real vibration data [36], [38].

6.2.4. Periodic systems

Participants: Ivan Guéguen, Laurent Mevel.

The modal analysis of a wind turbine has been generally handled with the assumption that this structure can be accurately modeled as linear time-invariant. Such assumption may be misleading for stability analysis, especially, with the current development of very large wind turbines with complex dynamic behavior (nonlinearity, aeroelastic coupling). Therefore in this paper, the inherent periodically time-varying dynamics of wind turbines (and for rotating systems, in general) is taken into account. Recently a subspace algorithm for modal analysis of rotating systems has been proposed. It is tested on a simulated and real data from a wind turbine [20], [41].

6.2.5. Identification of finite impulse response systems based on quantized output measurements – a quadratic programming-based method

Participant: Qinghua Zhang.

This work has been carried out in collaboration with Jiandong Wang (Peking University, China).

Quantized data are typically produced by the process of analog-to-digital conversion and have been widely studied in signal encoding and digital representation. In system identification, the processed data are usually collected after a quantization procedure, but the effect of quantization is often ignored. The study on system identification based on quantized data makes sense when the data are coded with few quantization levels, to the point that the effect of quantization becomes important. In this work we propose a quadratic programming (QP)-based method for identification of finite impulse response (FIR) dynamic systems from quantized or binary data. The main idea of the proposed method is to reformulate this identification problem, usually viewed as a nonlinear estimation problem with discontinuous nonlinearities, in the form of a standard QP problem, which is a convex optimization problem and can be solved efficiently. The complete input conditions ensuring the strict convexity of the QP problem are developed, and the consistency of the estimated parameters is established under the complete input conditions. The results of this study have been published in [27].

6.2.6. Wiener System Identification by Weighted Principal Component Analysis

Participant: Qinghua Zhang.

This work has been carried out in collaboration with Vincent Laurain (CRAN/CNRS/Université de Lorraine).

A Wiener system consists of two subsystems connected in series, with a linear dynamic subsystem preceding a static nonlinearity. In the field of control systems, the dynamics of a nonlinear system can often be linearized around its working point. Nevertheless, if its output sensor is affected by strongly nonlinear distortions, the linearization of the sensor characteristics may induce large modeling errors. In such situations, Wiener system model is more appropriate than fully linearized models. Wiener system identification is investigated in this work with a finite impulse response (FIR) model of the linear subsystem. Under the assumption of Gaussian input distribution, this work mainly aims at addressing a deficiency of the well-known correlation-based method for Wiener system identification: it fails when the nonlinearity of the Wiener system is an even function. This method is, in the considered Gaussian input case, equivalent to the best linear approximation (BLA) method, which exhibits the same deficiency. Our new method is based on a weighted principal component analysis (wPCA). Its consistency is proved for Wiener systems with either even or non even nonlinearities. Its computational cost is almost the same as that of a standard PCA. The results of this study have been presented at [51].

6.2.7. Industrial process for road buildings

Participant: Jean Dumoulin.

The increasing use of the baffled-rotary kiln equipment in many innovative materials processing industrial applications suggests examining the heat transfer phenomena in order to improve the multi-phase flow modeling tools. Their development and use will be relevant for tackling the current energy issues. The heat transfer models available for the rotary kiln in the literature are, for now, not enough efficient for the baffled-rotary kiln case. The present paper is aimed at suggesting a wall heat transfer correlation for the rotary kilns with the secondary inlet. The experimental thermal data acquired within large-scale rotary drum applied to the asphalt concrete materials production, are remained in order to give rise the new issues. These latter results are connected to a visualization campaign performed at the pilot-scale in order to assess the transversal distribution of the granular phase materials. Their analysis suggests a more appropriate physical modelling of the wall heat transfer path. It leads to transform the classical correlation of type $Nu = f(Re, Pr)$ in a new expression of type $Nu = f(Re, St)$ based on a new physical modeling inventory corresponding to the hot and cold fluxes flowing within the baffled-rotary kiln. Thus, the major modification is based on the introduction of the Stanton (St) number in the wall heat transfer correlation. This expression is found more convenient for the baffled-rotary kiln application. This new expression is validated by the comparison with the experimental Nusselt numbers calculated from the inner heat transfer measurements coefficient measured in the baffled-rotary kiln performed at large scale [21].

6.2.8. Industrial process for concrete structure repair

Participant: Jean Dumoulin.

In civil engineering, reinforced concrete repair by CFRP is a strengthening technique that has proven successfully in the past. The present study is aimed at using thermoplastic CFRP sheets applied and glued under heat. In this research framework, active thermography is used to accomplish two roles: control of the operating temperature of the thermoplastic CFRP sheets during the installation process and evaluation of the bonding quality after welding. The paper presents results obtained in laboratory with a dedicated test bench coupled with numerical simulations of the process [49].

6.2.9. Building energy management

Participants: Alexandre Nassiopoulos, Jordan Brouns.

Problems such as parameter identification for model calibration, optimal design or optimal energy management can all be formulated in a similar framework as problems consisting in finding the minimum of a cost function. The paper presents the software ReTrofit that specifically treats this kind of problems applied to building energy performance models. ReTrofit is first of all a simulation tool for evaluating building thermal behavior and computing energy consumptions. The novelty compared to state-of-the-art energy simulation software is that it also integrates a generic set of tools and algorithms to set up and solve optimization problems related to the building thermal model. The use of the adjoint model, that is intrinsically implemented in the code, constructs fast and efficient algorithms to solve linear, non linear, constrained or unconstrained problems addressing a wide range of applications [43].

6.3. damage detection for mechanical structures

6.3.1. Damage detection and localisation

Participants: Michael Doehler, Luciano Gallegos, Laurent Mevel.

The Stochastic Dynamic Damage Locating Vector approach is a vibration-based damage localization method based on a finite element model of a structure and output-only measurements in both reference and damaged states. A stress field is computed for loads in the null space of a surrogate of the change in the transfer matrix at the sensor positions for some values in the Laplace domain. Then, the damage location is related to positions where the stress is close to zero. Robustness of the localization information can be achieved by aggregating results at different values in the Laplace domain. So far, this approach and in particular the aggregation is deterministic and does not take the uncertainty in the stress estimates into account. In this paper, the damage localization method is extended with a statistical framework. The uncertainty in the output-only measurements is propagated to the stress estimates at different values of the Laplace variable and these

estimates are aggregated based on statistical principles. The performance of the new statistical approach is demonstrated both in a numerical application and a lab experiment, showing a significant improvement of the robustness of the method due to the statistical evaluation of the localization information [22], [37].

6.3.2. *An Innovations Approach to Fault Diagnosis in Linear Time-Varying Descriptor Systems*

Participant: Qinghua Zhang.

This work has been carried out in collaboration with Abdouramane Moussa-Ali (LSIS/CNRS/Université de Toulon).

Many modern engineering systems can be modeled by explicit ordinary differential equations (ODE) in state-space form. Such state-space equations have a long-term mathematical history, and a large number of analytical and numerical tools have been developed for their study. Nevertheless, some systems cannot be described by such explicit state-space models, but described by *implicit* differential equations, known as differential-algebraic equations (DAE). After linearization along a trajectory and discretization in time, a nonlinear DAE system is approximately described by *implicit* discrete time state-space equations, known as *descriptor system equations*. In this work, fault diagnosis is studied for time varying descriptor systems. The Kalman filter for descriptor systems is first revisited by completing existing results about its properties that are essential for the purpose of fault diagnosis. Based on the analysis of the effects of the considered actuator and sensor faults on the innovation of the descriptor system Kalman filter, it is shown that the considered fault diagnosis problem in time varying descriptor systems is equivalent to a classical linear regression problem formulated by appropriately filtering the input-output data. Following this result, algorithms for fault diagnosis through maximum likelihood estimation are then developed. The results of this study have been presented at [42].

6.3.3. *Statistical detection and isolation of additive faults in linear time-varying systems*

Participant: Qinghua Zhang.

This work has been carried out in collaboration with Michèle Basseville (IRISA/CNRS).

Model-based approaches to fault detection and isolation (FDI) have been mostly studied in the literature for linear time invariant (LTI) systems. In practice, quite often time-varying and/or nonlinear properties of the monitored system cannot be neglected. One of the possible approaches to dealing with nonlinear systems is based on the linearization along the actual or nominal trajectory of the monitored system. Such a linearization generally leads to linear time-varying (LTV) systems, whereas the more basic LTI approximation is usually related to the linearization around a single working point. It is thus clear that methods for FDI in LTV systems are much more powerful than their LTI counterparts. In the present work, we address the FDI problem for LTV systems subject to parametric additive faults. The proposed approach is statistical, by combining a generalized likelihood ratio (GLR) test with the Kalman filter that cancels out the dynamics of the faults effects in the considered LTV systems. With this approach, it is possible to perform fault isolation when the number of sensors is smaller than the number of assumed faults, under an appropriate assumption about the excitation of the system. The results of this study have been published in [29].

6.3.4. *Robust subspace damage detection*

Participants: Michael Doehler, Laurent Mevel.

In the last ten years, monitoring the integrity of the civil infrastructure has been an active research topic, including in connected areas as automatic control. It is common practice to perform damage detection by detecting changes in the modal parameters between a reference state and the current (possibly damaged) state from measured vibration data. Subspace methods enjoy some popularity in structural engineering, where large model orders have to be considered. In the context of detecting changes in the structural properties and the modal parameters linked to them, a subspace-based fault detection residual has been recently proposed and applied successfully, where the estimation of the modal parameters in the possibly damaged state is avoided. However, most works assume that the unmeasured ambient excitation properties during measurements of the structure in the reference and possibly damaged condition stay constant, which is hardly satisfied by any application. This paper addresses the problem of robustness of such fault detection methods. It is explained

why current algorithms from literature fail when the excitation covariance changes and how they can be modified. Then, an efficient and fast subspace-based damage detection test is derived that is robust to changes in the excitation covariance but also to numerical instabilities that can arise easily in the computations. Three numerical applications show the efficiency of the new approach to better detect and separate different levels of damage even using a relatively low sample length [18], [35], [17].

6.3.5. *Sensor placement*

Participant: Michael Doehler.

Deciding on the position of sensors by optimizing the utility of the monitoring system over a structure lifetime is typically forbidden by computational cost. Sensor placement strategies are, instead, usually formulated for a pre-selected number of sensors and are based on cost functions that can be evaluated for any arrangement without the need for simulations. This paper examines the performance of two such schemes, the first one is derived directly from a technique that detects damage from the shift of a chi-square distribution from central to non-central and takes the optimal arrangement as the one that maximizes the sensitivity of the non-centrality to all parameter changes of equal norm. The second scheme selects the sensor arrangement as that which maximizes a weighted version of the norm of the sensitivity of the covariance of the output to all feasible changes in system parameters. The performance of the two schemes is tested in simulations [32].

6.3.6. *Reflectometry for external post-tensioned cable monitoring*

Participant: Qinghua Zhang.

This work has been carried out in collaboration with IFSTTAR, EDF, ENS Cachan and Andra.

Nowadays a considerable number of bridges is reaching an age when repairs become necessary. In some bridges, external post-tension cables are placed in ducts within which the residual internal space is imperfectly filled with a fluid cement grout. Detecting the defaults of filling is visually impossible from the outside. Among non-destructive detection techniques proposed for cable health monitoring, reflectometry techniques offer remarkable advantages in that they can monitor cables in concrete deviator (embedded in concrete) and they do not require human intervention inside the bridge. In this work, the application of reflectometry techniques to cable health monitoring has been investigated via numerical simulations and laboratory experiments. The results of this study have been presented at [53].

6.3.7. *Efficient Computation of Minmax Tests for Fault Isolation and Their Application to Structural Damage Localization*

Participants: Michael Doehler, Laurent Mevel.

Fault detection and isolation can be handled by many different approaches. This paper builds upon a hypothesis test that checks whether the mean of a Gaussian random vector has become non-zero in the faulty state, based on a chi2 test. For fault isolation, it has to be decided which components in the parameter set of the Gaussian vector have changed, which is done by variants of the chi2 hypothesis test using the so-called sensitivity and minmax approaches. While only the sensitivity of the tested parameter component is taken into account in the sensitivity approach, the sensitivities of all parameters are used in the minmax approach, leading to better statistical properties at the expense of an increased computational burden. The computation of the respective test variable in the minmax test is cumbersome and may be ill-conditioned especially for large parameter sets, asking hence for a careful numerical evaluation. Furthermore, the fault isolation procedure requires the repetitive calculation of the test variable for each of the parameter components that are tested for a change, which may be a significant computational burden. In this paper, dealing with the minmax problem, we propose a new efficient computation for the test variables, which is based on a simultaneous QR decomposition for all parameters. Based on this scheme, we propose an efficient test computation for a large parameter set, leading to a decrease in the numerical complexity by one order of magnitude in the total number of parameters. Finally, we show how the minmax test is useful for structural damage localization, where an asymptotically Gaussian residual vector is computed from output-only vibration data of a mechanical or a civil structure [39].

6.3.8. Inverse problems in damage detection

Participant: Dominique Siegert.

Reinforced concrete beams are widely employed in civil engineering structures. To reduce the maintenance financial cost, structure damages have to be detected early. To this end, one needs robust monitoring techniques. The paper deals with the identification of mechanical parameters, useful for Structural Health Monitoring, in a 2D beam using inverse modeling technique. The optimal control theory is employed. As an example, we aim to identify a reduction of the steel bar cross-section and a decrease of the concrete Young modulus in damaged areas. In our strategy, the beam is instrumented with strain sensors, and a known dynamic load is applied. In the inverse technique, two space discretizations are considered: a fine discretization to solve the structural dynamic problem and a coarse discretization for the beam parameter identification. To get the beam parameters, we minimize a classical data misfit functional using a gradient-like algorithm. A low-cost computation of the functional gradient is performed using the adjoint equation. The inverse problem is solved in a general way using engineer numerical tools: Python scripts and the free finite element software Code Aster. First results show that a local reduction of the steel bar cross-section and a local decrease of concrete Young modulus can be detected using this inverse technique [25].

6.3.9. NDT by active thermography coupled with infrared shearography

Participant: Jean Dumoulin.

As infrastructures are aging, the evaluation of their health is becoming crucial. To do so, numerous Non Destructive Testing (NDT) methods are available. Among them, thermal shearography and active infrared thermography represent two full field and contactless methods for surface inspection. The synchronized use of both methods presents multiples advantages. Most importantly, both NDT are based on different material properties. Thermography depend on the thermal properties and shearography on the mechanical properties. The cross-correlation of both methods result in a more accurate and exact detection of the defects. For real site application, the simultaneous use of both methods is simplified due to the fact that the excitation method (thermal) is the same. Active infrared thermography is the measure of the temperature by an infrared camera of a surface subjected to heat flux. Observation of the variation of temperature in function of time reveal the presence of defects. On the other hand, shearography is a measure of out-of-plane surface displacement. This displacement is caused by the application of a strain on the surface which (in our case) take the form of a temperature gradient inducing a thermal stress [56], [47], [48].

6.4. Long term monitoring of civil engineering structure

6.4.1. ICT based software for thermal field long term monitoring of civil engineering structures

Participants: Antoine Crinière, Jean Dumoulin.

Aging of transport infrastructures combined with traffic and climatic solicitations contribute to the reduction of their performances. To address and quantify the resilience of civil engineering structure, investigations on robust, fast and efficient methods are required. Among research works carried out at IFSTTAR, methods for long term monitoring face an increasing demand. Such works take benefits of this last decade technological progresses in ICT domain. A multi-sensing techniques system, able to date and synchronize measurements carried out by infrared thermography coupled with various measurements data (i.e. weather parameters), have been designed, developed and implemented on real site. This smart sensor called IrLaw/SENSORBOX has been upgraded in order to reach full autonomy and its able to monitor over years civil engineering structures [55], [15], [34].

6.4.2. Long term structural health monitoring architecture

Participant: Jean Dumoulin.

This work gives a brief description of the main activities and outcomes of the Integrated System for Transport Infrastructures surveillance and Monitoring by Electromagnetic Sensing (ISTIMES – www.istimes.eu) project, which was concerned with the development and implementation of a system able to couple the capabilities of long-term monitoring and quick damage assessment of the critical transport infrastructures. This was performed thanks to the integrated use of the novel and state of art concepts of Earth observation, ground-based sensing techniques and ICT architecture [45], [46].

6.5. Material characterization

6.5.1. *Quantitative non destructive testing in civil engineering*

Participants: Jordan Brouns, Antoine Crinière, Jean Dumoulin, Alexandre Nassiopoulos.

By the aging of civil engineering structures a crucial need of reparation or reinforcement appeared through years. This can be done using bonded CFRP plate to assure the mechanical behavior of the structure. This type of reparation need diagnosis to insure the reliability of the reparation procedure. This part focus on the development of 1D to 3D method to asses the quantitative non destructive testing of a repaired structure thanks to active thermography (see [14] and [52]).

6.5.2. *Thermo-physical characterization for civil engineering application*

Participant: Jean Dumoulin.

This papers presents the development of a new device for the determination of thermal conductivity and diffusivity of anisotropic composite plates. The excitation signal is provided through a thermoelectric cooler and does not require any optical source like a laser source for instance. Infrared thermography is used to follow apparent surface temperature evolution with time. Experiments were carried out two composite sample systems (with two different fiber orientations). Result analysis is presented and discussed [40].

6.5.3. *Emissivity characterization for civil engineering applications*

Participant: Jean Dumoulin.

The knowledge of the infrared emissivity of materials used in buildings and civil engineering structures is useful for two specific approaches. First, quantitative diagnosis of buildings or civil engineering infrastructures by infrared thermography requires emissivity values in the spectral bandwidth of the camera used for measurements, in order to obtain accurate surface temperatures; for instance, emissivity in the band III domain is required when using cameras with uncooled detectors (such as micro-bolometer arrays). Second, setting up accurate thermal balances by numerical modeling requires the total emissivity value for a large wavelength domain; this is, for instance, the case for computing the road surface temperature to predict ice occurrence. Furthermore, periodical surveys of emissivity variations due to aging or soiling of surfaces could be useful in many situations such as thermal mapping of roads or building insulation diagnosis. The use of portable emissivity measurement devices is required for that purpose. A device using an indirect measurement method was previously developed in our lab; the method uses measurement of the reflectivity from a modulated IR source and requires calibration with a highly reflective surface. However, that device uses a low-frequency, thermal modulation well adapted to laboratory measurements but unfit for fast and in situ measurements. Therefore, a new, portable system which retains the principle of an indirect measurement but uses a faster-frequency, mechanical modulation more appropriate to outdoor measurements was developed. Both devices allow measurements in the broad ($1\mu\text{m}$ to $40\mu\text{m}$) and narrow ($8\mu\text{m}$ to $40\mu\text{m}$) bands. Experiments were performed on a large number of materials commonly used in buildings and civil engineering structures. The final objective of this work is to build a database of emissivity of these materials. A comparison of laboratory and on-site measurements of emissivity values obtained in both spectral bands will be presented along with an estimation and an analysis of measurement uncertainties [23].

6.6. Vision under environmental conditions

6.6.1. *Infrared Imaging under environmental conditions*

Participant: Jean Dumoulin.

An infrared system has been developed to monitor transport infrastructures in a standalone configuration. It is based on low cost infrared thermal cameras linked with a calculation unit in order to produce a corrected thermal map of the surveyed structure at a selected time step. With the inline version, the data collected feed simplified radiative models running a GPU. With the offline version, the thermal map can be corrected when data are collected under different atmospheric conditions up to foggy night conditions. A model for radiative transmission prediction is proposed and limitations are addressed. Furthermore, the results obtained by image and signal processing methods with data acquired on the transport infrastructure opened to traffic are presented. Finally, conclusions and perspectives for new implementation and new functionalities are presented and discussed [16].

6.6.2. Long term thermal monitoring by uncooled infrared camera

Participant: Jean Dumoulin.

Being able to perform easily non-invasive diagnostics for surveillance and monitoring of critical transport infrastructures is a major preoccupation of many technical offices. Among all the existing electromagnetic methods, long term thermal monitoring by uncooled infrared camera is a promising technique due to its dissemination potential according to its low cost on the market. Nevertheless, Knowledge of environmental parameters during measurement in outdoor applications is required to carry out accurate measurement corrections induced by atmospheric effects at ground level. Particularly considering atmospheric effects and measurements in foggy conditions close as possible to those that can be encountered around transport infrastructures, both in visible and infrared spectra. In the present study, atmospheric effects are first addressed by using data base available in literature and modelling. Atmospheric attenuation by particles depends greatly of aerosols density, but when relative humidity increases, water vapor condenses onto the particulates suspended in the atmosphere. This condensed water increases the size of the aerosols and changes their composition and their effective refractive index. The resulting effect of the aerosols on the absorption and scattering of radiation will correspondingly be modified [54].

6.6.3. Handling of fog conditions by infrared cameras

Participant: Jean Dumoulin.

Fog conditions are the cause of severe car accidents in western countries because of the poor induced visibility. Its forecast and intensity are still very difficult to predict by weather services. Infrared cameras allow to detect and to identify objects in fog while visibility is too low for eye detection. Over the past years, the implementation of cost effective infrared cameras on some vehicles has enabled such detection. On the other hand pattern recognition algorithms based on Canny filters and Hough transformation are a common tool applied to images. Based on these facts, a joint research program between IFSTTAR and Cerema has been developed to study the benefit of infrared images obtained in a fog tunnel during its natural dissipation. Pattern recognition algorithms have been applied, specifically on road signs which shape is usually associated to a specific meaning (circular for a speed limit, triangle for an alert, ...). It has been shown that road signs were detected early enough in images, with respect to images in the visible spectrum, to trigger useful alerts for Advanced Driver Assistance Systems [33].

Maxplus Project-Team

6. New Results

6.1. Highlights of the Year

Nous avons donné un contre exemple inattendu à l’analogie continu de la conjecture de Hirsch, proposé par Deza, Terlaky et Zinchenko, voir Section 6.4.4 .

English version

We gave a somehow unexpected counter example to the continuous analogue of the Hirsch conjecture proposed by Deza, Terlaky and Zinchenko, see Section 6.4.4 .

6.2. Théorie spectrale max-plus et géométrie métrique/Max-plus spectral theory and metric geometry

6.2.1. Introduction

Participants: Marianne Akian, Stéphane Gaubert, Cormac Walsh.

Étant donné un noyau $a : S \times S \rightarrow \mathbb{R} \cup \{-\infty\}$, on peut lui associer le problème spectral max-plus

$$\sup_{y \in S} a(x, y) + u(y) = \lambda + u(x), \quad \forall x \in S, \quad (2)$$

dans lequel on cherche le vecteur propre $u : S \rightarrow \mathbb{R} \cup \{-\infty\}$ et la valeur propre correspondante $\lambda \in \mathbb{R} \cup \{-\infty\}$. Comme nous l’avons rappelé dans les §3.2 et 3.3 , le problème spectral (9) intervient en contrôle ergodique: l’ensemble S est l’espace des états, et l’application $a(x, y)$ fournit le gain associé à la transition $x \rightarrow y$. Le cas où S est fini est classique, l’on a alors un résultat précis de représentation de l’espace propre, à l’aide d’un certain graphe, dit graphe critique. Des résultats existent également lorsque S est compact et que le noyau vérifie certaines propriétés de régularité.

Dans [64], nous avons considéré le cas où S est non compact. Lorsque $\lambda = 0$, l’espace propre est analogue à l’espace des fonctions harmoniques défini en théorie (classique ou probabiliste) du potentiel. En introduisant l’analogie max-plus de la frontière de Martin, nous avons obtenu un analogue de la formule de représentation de Poisson des fonctions harmoniques : toute solution u de (9) peut être représentée sous la forme :

$$u = \sup_{w \in \mathcal{M}_m} w + \mu_u(w) , \quad (3)$$

où $\mathcal{M}_m \subset (\mathbb{R} \cup \{-\infty\})^S$ est l’analogie max-plus de la frontière de Martin minimale (l’ensemble des fonctions harmoniques extrémales normalisées), et où μ_u joue le rôle de la mesure spectrale. Nous avons montré aussi que les éléments de l’espace de Martin minimal peuvent être caractérisés comme les limites de “quasi-géodésiques”. La frontière de Martin max-plus généralise dans une certaine mesure la frontière d’un espace métrique construite à partir des horo-fonctions (fonctions de Busemann généralisées), ou horo-frontière. Ces résultats inspirent les travaux des sections suivantes, qui portent sur des cas remarquables d’espaces métriques (§6.2.3) ou sur des applications en théorie des jeux (§6.2.2).

English version

Let the kernel $a : S \times S \rightarrow \mathbb{R} \cup \{-\infty\}$ be given. One may associate the max-plus spectral equation (9), where the eigenvector $u : S \rightarrow \mathbb{R} \cup \{-\infty\}$ and the eigenvalue $\lambda \in \mathbb{R} \cup \{-\infty\}$ are unknown. As we recalled in §3.2 and refmonotone, this spectral problem arises in ergodic optimal control: the set S is the *state space*, and the map $a(x, y)$ is the *transition reward*. The case when S is finite is classical, a precise spectral theorem is known, with a characterisation of the eigenspace in terms of a critical graph. Some results have been shown when S is compact, assuming that the kernel a satisfies some regularity properties.

In [64], we considered the case where S is non-compact. When $\lambda = 0$, the eigenspace is analogous to the set of harmonic functions defined in classical or probabilistic potential theory. By introducing a max-plus analogue of the classical Martin boundary, we obtained an analogue of the Poisson representation of harmonic functions, showing that any solution u of (9) may be represented as in (10) where $\mathcal{M}_m \subset (\mathbb{R} \cup \{-\infty\})^S$ is a max-plus analogue of the minimal Martin boundary (the set of normalised extremal harmonic functions), and μ_u plays the role of the spectral measure. We also showed that the elements of the minimal Martin boundary can be characterised as limits of certain “almost-geodesics”. The max-plus Martin boundary generalises to some extent the boundary of metric spaces defined in terms of horofunctions (generalised Busemann functions), or horoboundary. These results have inspired the work of the next sections, which deal either with interesting examples of metric spaces (§6.2.3) or with applications to zero-sum games (§6.2.2).

6.2.2. *Asymptotiques d’itérées d’applications contractantes au sens large et jeux à somme nulle en horizon long/Asymptotics of iterates of nonexpansive mappings and zero-sum games*

Participants: Jérôme Bolte, Stéphane Gaubert, Guillaume Vigeral.

On s’est intéressé ici à l’existence du paiement moyen pour les jeux répétés, et plus généralement, à l’existence du vecteur de “taux de fuite” $\lim_k f^k(x)/k$ où f est une application de \mathbb{R}^n dans lui même, nonexpansive pour une norme quelconque. Dans le cas particulier des jeux, f est un opérateur de Shapley, qui est nonexpansif pour la norme sup. On a montré dans [15] que la limite existe si l’application f est définissable dans une structure o-minimale. Ceci généralise des résultats de Bewley, Kohlberg, et Neyman, qui montraient que la limite existe si f est semi-algébrique. L’extension au cas o-minimal permet notamment de traiter des opérateurs de type “log-exp” apparaissant en contrôle sensible au risque.

English version

We studied the question of the existence of the mean payoff for repeated games, and more generally, the existence of a vector of “escape rates”, $\lim_k f^k(x)/k$, where f is a self-map of \mathbb{R}^n , non-expansive in some norm. In the special case of zero-sum games, f is a Shapley operator, and it is sup-norm nonexpansive. We showed in [15] that this limit does exist as soon as the map f is definable in an o-minimal structure. This generalizes results of Bewley, Kohlberg, and Neyman, who showed that this limit exists if f is semi-algebraic. The extension to the case of o-minimal structures allows one in particular to deal with log-exp type operators arising in risk sensitive control.

6.2.3. *Isométries de la géométrie de Hilbert/Isometries of the Hilbert geometry*

Participants: Cormac Walsh, Bas Lemmens [Kent University, UK].

Dans nos travaux précédents, nous avons étudié la géométrie de Hilbert (d’un ensemble convexe) en dimension finie, en particulier son horo-frontière et son groupe des isométries. Le chapitre de livre [44] donne une vue d’ensemble de ces travaux. Le cas de la dimension infinie est aussi intéressant, et a été utilisé depuis de nombreuses années en analyse non linéaire. Malgré cela, la géométrie de ces espaces est très peu connue en dimension infinie. Nous collaborons sur ce sujet avec Bas Lemmens de l’Université de Kent. Nous étudions par exemple le problème suivant. En dimension finie, il est connu que la géométrie de Hilbert est isométrique à un espace normé si et seulement si le convexe est un simplexe. Nous essayons de montrer plus généralement que la géométrie de Hilbert est isométrique à un espace de Banach si et seulement si le convexe est le cône des fonctions positives continues sur un espace topologique compact. Pour cela, nous étudions l’horo-frontière en dimension infinie.

English version

Previously, we have been studying the Hilbert geometry in finite dimensions, especially its horofunction boundary and isometry group. The book chapter [44] contains a survey of this work. However, the infinite dimensional case is also interesting, and has been used as a tool for many years in non-linear analysis. Despite this, very little is known about the geometry of these spaces when the dimension is infinite. We are collaborating on this topic with Bas Lemmens of the University of Kent. An example of a problem we are working on is the following. In finite dimension it is known that a Hilbert geometry is isometric to a normed space if and only if it is a simplex. We are attempting to show that, more generally, a Hilbert geometry is isometric to a Banach space if and only if it is the cross-section of a positive cone, that is, the cone of positive continuous functions on some compact topological space. To tackle this problem we are finding it useful to study the horofunction boundary in the infinite-dimensional case.

6.2.4. Croissance des boules dans la géométrie de Hilbert/Volume growth in the Hilbert geometry

Participants: Cormac Walsh, Constantin Vernicos [Université Montpellier 2].

Avec Constantin Vernicos de l'Université Montpellier 2, nous étudions la croissance du volume de la boule d'une géométrie de Hilbert (d'un ensemble convexe) en fonction du rayon. En particulier, nous étudions l'entropie volumique:

$$\lim_{r \rightarrow \infty} \frac{\log \text{Vol } B(x, r)}{r}, \quad (4)$$

où $B(x, r)$ désigne la boule de centre x et de rayon r , et Vol est une notion de volume particulière, telle que celle définie par Holmes–Thompson ou celle de Busemann. L'entropie ne dépend pas du choix particulier de x , ni de celui du volume. Il est connu que pour l'espace hyperbolique, ou toute géométrie de Hilbert dont la frontière est C^2 et de courbure strictement positive, l'entropie est égale à $n - 1$ lorsque la dimension de l'espace est n , et il a été conjecturé que ceci correspond aussi à l'entropie maximale d'une géométrie de Hilbert en dimension n . Afin de prouver cette conjecture, nous cherchons d'abord à étudier le lien entre l'entropie et l'approximabilité du convexe par des polytopes, et ensuite à borner cette approximabilité. La première étape nécessite d'étudier la croissance du volume dans le cas de polytopes. Dans ce cas, la croissance est polynomiale de degré n , plutôt qu'exponentielle, et il est important de comprendre le lien entre le coefficient dominant du polynôme exprimant le volume et la complexité du polytope. Nous avons obtenu une formule pour ce coefficient, laquelle dépend de la structure combinatoire du polytope.

English version

In a collaboration with Constantin Vernicos of Université Montpellier 2, we are investigating how the volume of a ball in a Hilbert geometry grows as its radius increases. Specifically, we are studying the volume entropy (11) where $B(x, r)$ is the ball with center x and radius r , and Vol denotes some notion of volume, for example, the Holmes–Thompson or Busemann definitions. Note that the entropy does not depend on the particular choice of x , nor on the choice of the volume. It is known that the hyperbolic space, or indeed any Hilbert geometry with a C^2 -smooth boundary of strictly positive curvature, has entropy $n-1$, where n is the dimension, and it has been conjectured this is the maximal entropy possible for Hilbert geometries of the given dimension. Our approach to this conjecture is to first relate the entropy to the approximability of the convex domain by polytopes, and then bound this approximability. The first of these steps requires us study the volume growth in the polytopal case. Here the growth is polynomial rather than exponential, of degree n , and it is important to know how the constant on front of the highest term depends on the complexity of the polytope. We have a formula for this constant in terms of the combinatorial structure of the polytope.

6.2.5. Consensus non-commutatif et contraction d'opérateurs de Kraus/Noncommutative consensus and contraction of Kraus maps

Participants: Stéphane Gaubert, Zheng Qu.

Dans le travail [17], on s'est intéressé à la vitesse de convergence vers l'équilibre d'une itération de la forme $x^{k+1} = T(x^k)$, $x^k \in X$, où T est une application linéaire préservant un cône dans un espace de Banach X , telle que $T(e) = e$, pour un certain vecteur e dans l'intérieur du cône. On s'intéresse aussi à l'itération dans l'espace dual, $y^{k+1} = T^*(y^k)$, $y^k \in X^*$, lorsque $\langle y^0, e \rangle = 1$.

Le cas classique est celui où $T(x) = Px$ est un opérateur de Markov. L'itération primale traduit alors la convergence vers le "consensus", et l'itération duale traduit la convergence de la distribution de probabilité en temps k vers l'état stationnaire. Dans ce cas, le taux de contraction (en un coup) $\kappa(P)$ d'une itération primale, pour la semi-norme de Hilbert $\|z\|_H := \max_i z_i - \min_j z_j$, ainsi que le taux de contraction d'une itération duale, pour la métrique en variation totale, coïncident et sont caractérisés par une formule due à Doeblin et Dobrushin (coefficient d'ergodicité),

$$\kappa(P) := 1 - \min_{i,j} \sum_{s=1}^n \min(P_{is}, P_{js}).$$

On a donné ici une généralisation de cette formule au cas d'opérateurs abstraits, qui s'applique en particulier aux opérateurs de Kraus qui interviennent en information quantique. Ces derniers opèrent sur l'espace des matrices symétriques, et sont de la forme

$$T(x) = \sum_k a_k x a_k^* \quad \text{avec} \quad \sum_k a_k a_k^* = I .$$

Dans [53], nous avons étudié des questions de complexité pour les applications de Kraus, montrant en particulier qu'il est NP-dur de vérifier qu'une application de Kraus envoie le cône dans son intérieur.

English version

In [17], we studied the speed of convergence to equilibrium of an iteration of the form $x^{k+1} = T(x^k)$, $x^k \in X$, where T is a linear map preserving a cone in a Banach space X , such that $T(e) = e$, for some vector e in the interior of the cone. We also considered the iteration in the dual space X^* , $y^{k+1} = T^*(y^k)$, $y^k \in X^*$, where $\langle y^0, e \rangle = 1$.

The classical application arises when $T(x) = Px$ is a Markov operator. Then, the primal iteration represents the dynamics of consensus, whereas the dual iteration represents the evolution of the probability distribution as a function of time. Then, the (one-shot) contraction rate $\kappa(P)$ of the primal iteration, with respect to Hilbert's seminorm $\|z\|_H := \max_i z_i - \min_j z_j$, and the contraction rate of the dual iteration, with respect to the total variation metric, coincide, and are characterized by a formula of Doeblin and Dobrushin (ergodicity coefficient),

$$\kappa(P) := 1 - \min_{i,j} \sum_{s=1}^n \min(P_{is}, P_{js}).$$

We gave here a generalization of this formula to an abstract operators on a cone. This covers in particular the Kraus maps arising in quantum information theory. The latter maps act on the space of symmetric matrices. They can be written as

$$T(x) = \sum_k a_k x a_k^* \quad \text{with} \quad \sum_k a_k a_k^* = I .$$

In [53], we studied complexity issues related to Kraus maps, and showed in particular that checking whether a Kraus map sends the cone to its interior is NP-hard.

6.3. Algèbre linéaire max-plus, convexité tropicale et jeux à somme nulle/Max-plus linear algebra, tropical convexity and zero-sum games

6.3.1. Polyèdres tropicaux/Tropical polyhedra

Participants: Xavier Allamigeon, Stéphane Gaubert, Eric Goubault [CEA], Ricardo Katz [Conicet, Argentine].

On étudie les analogues max-plus ou tropicaux des ensembles convexes. Ceux-ci sont utiles en particulier pour représenter de manière effective les ensembles d'états accessibles de systèmes à événements discrets [9], ils sont aussi apparus récemment en géométrie tropicale, dans toute une série de travaux à la suite de Sturmfels et Develin [108]. Les polyèdres max-plus peuvent aussi être vus comme des limites de déformations de polyèdres classiques, sur lesquels ils donnent un éclairage de nature combinatoire. Toutes ces motivations ont inspiré la recherche d'analogues des résultats fondamentaux d'analyse convexe classique: séparation, projection, points extrémaux, à la suite en particulier de [8].

Dans un travail de X. Allamigeon, S. Gaubert, et E. Goubault [71], [72], on a mis en évidence un critère combinatoire pour la caractérisation des sommets des polyèdres tropicalement convexes. Celui-ci s'exprime à l'aide d'hypergraphes orientés, et de leurs composantes fortement connexes. Ce critère possède la propriété d'être vérifiable en un temps presque linéaire en la taille de l'hypergraphe.

On en déduit un analogue tropical de la méthode de la double description [72] (méthode très utilisée sur les polyèdres classiques, et due à Motzkin *et al.* [160]). Cet algorithme permet de calculer les sommets d'un polyèdre défini de façon externe (intersection de demi-espaces ou d'hyperplans tropicaux). Grâce au critère combinatoire précédent, l'algorithme améliore de plusieurs ordres de grandeur les techniques connues jusqu'alors. Ceci est confirmé par de nombreuses expérimentations. Ce travail est motivé par des applications à l'analyse statique [70] et aux systèmes à événements discrets [113], dans lesquelles la manipulation de tels polyèdres est le goulot d'étranglement.

Il est connu qu'un polyèdre tropical peut être représenté comme l'enveloppe convexe d'un ensemble minimal de points et rayons, donnés par ses sommets et ses rayons extrêmes [124]. Dans un travail réalisé par X. Allamigeon et R. Katz [75], et effectué en partie lors de visites de R. Katz à Inria, on étudie la question duale de la caractérisation des représentations minimales par demi-espaces. On montre qu'un polyèdre tropical possède *essentiellement* une unique représentation minimale par demi-espaces, lorsque leurs apex appartiennent au polyèdre. On montre que les apex de ces demi-espaces non-redondants correspondent à certains sommets du complexe tropical introduit par Develin et Sturmfels [108]. On introduit également un critère combinatoire pour l'élimination de demi-espaces redondants à l'aide d'hypergraphes orientés.

Dans un travail de X. Allamigeon et R. Katz [52], nous étudions la tropicalisation des représentations par demi-espaces des polyèdres convexes sur le corps des séries de Puiseux. Nous démontrons ainsi une conjecture de Develin et Yu [109]. Celle-ci assure qu'étant donné un polytope tropical pur, il existe un polytope *relevé* sur les séries de Puiseux, dont les demi-espaces associés aux faces se "tropicalisent" en une représentation par demi-espaces du polytope tropical initial.

Des applications de ces travaux à l'algorithmique, concernant en particulier les jeux répétés, sont discutées dans la Section 6.5.2. Une application aux systèmes temps réel est discutée dans la Section 6.6.4.

English version

We study the max-plus or tropical analogues of convex sets. These have been used in particular to represent effectively the accessible sets of certain discrete event systems [9]. They also appeared in tropical geometry, following the work of Sturmfels and Develin [108]. Max-plus polyhedra can be thought of as limits of deformations of classical polyhedra, on which they give a combinatorial insight. These motivations have inspired the investigation of analogues of basic results of classical convex analysis: separation, projection, representation by extreme points, following [8].

In a work of X. Allamigeon, S. Gaubert, and E. Goubault [72], we introduce a combinatorial criterion for the characterization of the vertices of tropically convex polyhedra. It is expressed in terms of directed hypergraphs and their strongly connected components. This criterion can be verified in almost linear time in the size of the hypergraph.

This allows to develop a tropical analogue of the double description method [72] (this method is widely used for classical convex polyhedra, and is due to Motzkin *et al.* [160]). This algorithm is able to determine all the vertices of a polyhedron defined externally (intersection of tropical half-spaces of hyperplanes). Thanks to the combinatorial criterion mentioned above, the algorithm improves the existing methods by several orders of magnitude. This is confirmed by several experiments. This is motivated by applications to static analysis [70] and discrete event systems [113], in which computing such polyhedra turns out to be the bottleneck.

It is well-known that a tropical polyhedron can be represented as the convex hull of a minimal set of points and rays, provided by its vertices and extreme rays [124]. In a work of X. Allamigeon and R. Katz [75], partly done during visits of R. Katz at Inria, the dual problem of characterizing the minimal representations by half-spaces is studied. We show that a tropical polyhedron admits *essentially* a unique minimal external representation by half-spaces, provided that their apices belong to the polyhedron. We prove that the apices of these half-spaces correspond to certain vertices of the tropical complex introduced by Develin and Sturmfels [108]. We also establish a combinatorial criterion allowing to eliminate redundant half-spaces using directed hypergraphs.

In a work of X. Allamigeon and R. Katz [52], we study the tropicalization of the representation by half-spaces of convex polyhedra over the field of Puiseux series. In particular, we prove a conjecture of Develin and Yu [109]. It states that, given a pure tropical polytope, there exists a lifting polytope over Puiseux series, such that the facet-defining half-spaces are “tropicalized” into a representation by half-spaces of the initial polytope.

Some algorithmic applications of this work concerning in particular mean payoff games, will be discussed in Section 6.5.2. Applications to real time systems will be discussed in Section 6.6.4.

6.3.2. *Systèmes linéaires max-plus/Max-plus linear systems*

Participants: Marianne Akian, Stéphane Gaubert, Alexander Guterman [Moscow State University].

Dans [42], on montre des formules de Cramer pour des systèmes linéaires sur diverses extensions du semi-anneau max-plus. Les éléments de ces extensions sont des nombres tropicaux enrichis d’une information de multiplicité, de signe ou d’angle par exemple. On obtient ainsi des résultats d’existence et d’unicité qui généralisent plusieurs résultats de [133], [164], [120], [172], [139]. De plus, pour certaines extensions du semi-anneau max-plus, les preuves fournissent des algorithmes de type Jacobi ou Gauss-Seidel pour résoudre les systèmes linéaires.

Nous nous intéressons maintenant à la complexité de la solution de systèmes linéaires tropicaux signés, i.e. de systèmes sur l’extension du semi-anneau max-plus avec signes, ou d’hyperplans sur ce semi-anneau.

English version

In [42], we prove general Cramer type theorems for linear systems over various extensions of the tropical semiring, in which tropical numbers are enriched with an information of multiplicity, sign, or argument. We obtain existence or uniqueness results, which extend or refine earlier results in [133], [164], [120], [172], [139]. Moreover, some of our proofs lead to Jacobi and Gauss-Seidel type algorithms to solve linear systems in suitably extended tropical semirings.

We study now the complexity of the solution of signed tropical linear systems, that is systems on the extension of the tropical semiring with signs, or the one of the nonemptiness of hyperplanes over this semiring.

6.3.3. *Convexes tropicaux et théorème de Choquet/Tropical convex sets and Choquet theorem*

Participants: Marianne Akian, Stéphane Gaubert, Paul Poncet.

La thèse de Paul Poncet [165] concernait essentiellement ce que l'on appelle l'analyse idempotente, c'est-à-dire l'étude des espaces fonctionnels ou linéaires de dimension infinie sur l'algèbre tropicale, ou tout autre semi-anneau idempotent. Paul Poncet a développé pour cela un point de vue treillis continu comme dans [1], ou plus généralement domaines. Depuis la soutenance, plusieurs articles issus du manuscrit de thèse sont publiés [21], [20] ou en cours de soumission, et d'autres travaux poursuivant ceux de la thèse sont en cours avec les membres de l'équipe.

En particulier avec ce point de vue domaines, Paul Poncet a pu établir des théorèmes de type Krein-Milman, réciproque de Milman, et représentation de Choquet dans les semi-treillis [20] ou l'algèbre max-plus [38].

On sait que les résultats sur les convexes tropicaux de dimension infinie de [165] permettent de retrouver partiellement les résultats sur la frontière de Martin max-plus décrits dans la section 6.2.1. Dans un travail commun avec Klaus Keimel (TU-Darmstadt), nous essayons d'obtenir l'extension du théorème de représentation de Choquet tropical dans le cas d'ensembles ordonnés qui ne sont pas forcément des treillis tels que le cône des matrices symétriques positives muni de l'ordre de Loewner.

English version

The PhD thesis work of Paul Poncet [165] concerned essentially what is called idempotent analysis, that is the study of infinite dimensional functional or linear spaces over tropical algebra, or any other idempotent semiring. For this aim, Paul Poncet developed the point of view of continuous lattices, as in [1], or more generally of domains. Since the defense of his thesis, several papers derived from the thesis manuscript have been published [21], [20] or up to be submitted. Some other works pursuing the thesis work are done with team members.

In particular, using the point of view of domains, Paul Poncet showed results such as a Krein-Milman type theorem, a Milman converse type theorem, and a Choquet representation type theorem over semilattices [20] or over max-plus algebra [38].

We know that the results on infinite dimensional tropical convex sets of [165] allow one to recover at least partially the results on max-plus Martin boundaries described in Section 6.2.1. In a joint work with Klaus Keimel (TU-Darmstadt), we try to obtain the extension of the max-plus Choquet representation theorem in the case of ordered sets that are not necessarily semilattices, such as the cone of nonnegative symmetric matrices endowed with the Loewner order.

6.3.4. Points fixes d'applications monotones homogènes et jeux à somme nulle/Fixed points of order preserving homogeneous maps and zero-sum games

Participants: Marianne Akian, Stéphane Gaubert, Antoine Hochart.

Pour les jeux répétés à somme nulle, un problème de base est de savoir si le paiement moyen par unité de temps est indépendant de l'état initial. Ici, on définit le paiement moyen directement au moyen de l'opérateur de Shapley (ou de la programmation dynamique) du jeu, lequel préserve l'ordre et commute avec l'addition d'une constante. Dans le cas particulier des jeux à zero joueur, i.e. de chaînes de Markov avec fonctionnelle additive, la solution du problème ci-dessus est fournie par le théorème ergodique. Dans [46], on généralise ce résultat au cas des jeux répétés à espace d'états fini. Cette généralisation est basée sur l'étude de la sous-classe d'opérateurs de Shapley *sans-paiement* (le paiement a lieu seulement le dernier jour), lesquels commutent avec la multiplication par une constante positive. L'intérêt de cette sous-classe est qu'elle inclue la fonction de récession d'un opérateur de Shapley, lorsqu'elle existe. Nous montrons que le paiement moyen est indépendant de l'état initial pour toutes les perturbations des paiements instantanés dépendantes de l'état si, et seulement si, une condition d'ergodicité est vérifiée. Cette dernière est caractérisée par l'unicité, à constante additive près, du point fixe de la fonction de récession de l'opérateur de Shapley, ou, dans le cas particulier des jeux stochastiques à nombre fini d'actions et information parfaite, par une condition d'accessibilité dans un hypergraphe orienté, entre deux sous-ensembles conjugués d'états. On montre aussi que l'ergodicité d'un jeu ne dépend que de la probabilité de transition et qu'elle peut être vérifiée en temps polynomial lorsque le nombre d'états est fixé.

Lorsque un jeu est ergodique au sens ci-dessus, son paiement moyen est indépendant de l'état initial, et il coïncide avec la valeur propre non linéaire de l'opérateur de Shapley. De plus, le vecteur propre associé, appelé biais, permet de déterminer les stratégies stationnaires optimales. Un autre problème est alors de comprendre pour quelles classes de jeux, le biais est unique (à constante additive près). Dans [25], on considère des jeux avec un nombre fini d'états et d'actions, de paiements instantanés variables, mais de probabilités de transition fixes. On montre que le vecteur de biais, considéré comme une fonction des paiements instantanés, est unique génériquement (à constante additive près).

English version

A basic question for zero-sum repeated games consists in determining whether the mean payoff per time unit is independent of the initial state. Here the mean payoff is defined in terms of the Shapley operator (dynamic programming operator) of the game, which is an order preserving map commuting with the addition of a constant. In the special case of "zero-player" games, i.e., of Markov chains equipped with additive functionals, the answer to the above question is provided by the mean ergodic theorem. In [46], we generalize this result to repeated games with a finite state space. This generalization is based on the study of the subclass of *payment-free* Shapley operators (the payment only occurs when the game stops), which are commuting with the multiplication by a positive constant, and which include the recession function of any Shapley operator, when it exists. We show that the mean payoff is independent of the initial state for all state-dependent perturbations of the rewards if and only if an ergodicity condition is satisfied. The latter is characterized by the uniqueness modulo additive constants of the fixed point of the recession function of the Shapley operator, or, in the special case of stochastic games with finite action spaces and perfect information, by a reachability condition involving conjugate subsets of states in directed hypergraphs. We show that the ergodicity condition for games only depends on the support of the transition probability and that it can be checked in polynomial time when the number of states is fixed.

Under the above ergodicity condition, the mean payoff of the game is independent of the initial state, and it is characterized as the nonlinear eigenvalue of the Shapley operator. Moreover, the associated eigenvector, also called the bias, allows one to determine optimal stationary strategies. Then, another basic question is to understand for which classes of games the bias vector is unique (up to an additive constant). In [25], we consider games with finite state and action spaces, thinking of the transition payments as variable parameters, transition probabilities being fixed. We show that the bias vector, thought of as a function of the transition payments, is generically unique (up to an additive constant).

6.4. Algèbre max-plus, déformations et asymptotiques /Max-plus algebra, deformations and asymptotic analysis

6.4.1. Introduction

Comme indiqué dans le §3.7, l'algèbre max-plus est la limite d'une déformation de l'algèbre classique, ou plutôt du semi-corps des réels positifs. Elle peut aussi fournir des estimations de ces déformations, puisque

$$\max(a, b) \leq \epsilon \log(e^{a/\epsilon} + e^{b/\epsilon}) \leq \epsilon \log(2) + \max(a, b) . \quad (5)$$

L'utilisation de ces propriétés a déjà conduit dans le passé aux travaux sur les perturbations de valeurs propres [57], [56], [55], ou sur les grandes déviations [1], [61]. Dans les travaux qui suivent, nous exploitons ces propriétés dans des contextes reliés ou similaires à ceux de nos travaux précédents.

English version

As detailed in §3.7, max-plus algebra is the limit of a deformation of classical algebra, or more precisely of the semi-field of usual real positive numbers. It can also give estimations for these deformations using for instance (12). By using these properties, we already obtained some works on singular perturbations of matrix eigenvalues [57], [56], [55], or on large deviations [1], [61]. In the works described below, we are exploiting again these properties in contexts that are related or similar to those of our earlier works.

6.4.2. Méthodes tropicales de localisation de valeurs propres de matrices/Tropical methods for the localisation of matrix eigenvalues

Participants: Marianne Akian, Stéphane Gaubert, Andrea Marchesini.

Dans un travail avec Meisam Sharify [63], on a comparé les modules des valeurs propres d'un polynôme matriciel au moyen des racines tropicales du polynôme obtenu en appliquant une norme donnée aux coefficients. En particulier, on a obtenu des inégalités de type majorisation qui généralisent les bornes obtenues par Polya et Ostrowski dans le cas de polynômes scalaires.

Dans [12], on montre des inégalités de type majorisation entre les modules des valeurs propres d'une matrice et les valeurs propres tropicales de la matrice de ses modules. En particulier, les majorations généralisent l'inégalité de Friedland [119] concernant le rayon spectral.

Nous avons amélioré et généralisé ces inégalités [37], en appliquant différents changements de variables diagonaux à la matrice complexe initiale, lesquels sont construits à partir des variables duales du problème d'affectation optimale paramétrique construit à partir d'une matrice tropicale associée à la matrice complexe. En particulier, lorsqu'on les applique à une matrice companion par blocs, ces inégalités sont similaires à celles de [63].

English version

In a work with Meisam Sharify [63], we compared the moduli of the eigenvalues of a matrix polynomial to the tropical roots of a polynomial obtained by applying a norm to the coefficients of the original matrix polynomial. In particular, we obtained majorization type inequalities which generalize the bounds of Polya and Ostrowski available for scalar polynomials.

In [12], we show majorization type inequalities between the moduli of the eigenvalues of a complex matrix and the tropical eigenvalues of the matrix obtained by applying the modulus entrywise. In particular, the upper bounds generalize the inequality of Friedland [119] concerning the spectral radius. The above inequalities were obtained by using the permanent and tropical analogues of the exterior power of a matrix and by showing (combinatorially) properties of their eigenvalues similar to the ones of usual exterior powers.

We recently improved and generalized these inequalities, see [37], by applying to the original complex matrix, different diagonal scalings constructed from the dual variables of the parametric optimal assignment constructed from an associated tropical matrix. In particular, when applied to a block companion matrix, our inequalities are similar to the ones in [63].

6.4.3. Méthodes tropicales pour le calcul numérique de valeurs propres de matrices/Tropical methods for the numerical computation of matrix eigenvalues

Participants: Marianne Akian, Stéphane Gaubert, Andrea Marchesini.

Un des buts de la thèse d'Andrea Marchesini est d'utiliser les résultats de localisation de valeurs propres tels que ceux obtenus ci-dessus pour améliorer la précision des algorithmes de calcul numérique de valeurs propres de matrices ou de polynômes matriciels, en particulier en construisant des changements d'échelle exploitant les calculs tropicaux, à effectuer préalablement à l'appel d'algorithmes classiques comme QZ. Le "changement d'échelle tropical" introduit par Stéphane Gaubert et Meisam Sharify [127] dans le cas de polynôme matriciels quadratiques consiste en un changement de variable multiplicatif de la variable scalaire du polynôme matriciel. Dans un travail en collaboration avec Françoise Tisseur et James Hook de l'Université de Manchester [36], on considère aussi un changement de variables diagonal du polynôme matriciel construit à partir des variables duales du problème d'affectation optimale paramétrique construit dans l'esprit de [55]. On montre l'intérêt de ces changements d'échelle en terme de conditionnement des valeurs propres, et la supériorité du changement de variables diagonal par rapport au changement d'échelle tropical.

English version

One of goals of the PhD thesis of Andrea Marchesini is to use results on the localisation of eigenvalues like the above ones, to improve the accuracy of the numerical computation of the eigenvalues of a complex matrix or matrix polynomial, in particular by applying scaling methods using tropical techniques, which may be used before calling usual algorithms as QZ. The “tropical scaling” introduced by Stéphane Gaubert and Meisam Sharify [127] in the case of quadratic matrix polynomials consists in a multiplicative scaling of the scalar variable of the matrix polynomial. In a work with Françoise Tisseur and James Hook from Manchester University [36], we also consider a diagonal scaling of the matrix polynomial constructed from the dual variables of the parametric optimal assignment constructed in the same spirit as in [55]. We show the interest of these scaling methods on the eigenvalue conditioning, and the superiority of the diagonal scaling with respect to the tropical scaling.

6.4.4. Tropicalisation du chemin central, et application à la courbure/Tropicalization of the central path and application to the curvature

Participants: Xavier Allamigeon, Pascal Benchimol, Stéphane Gaubert, Michael Joswig [TU Berlin].

En optimisation, une classe importante d’algorithmes, dits *de points intérieurs*, consiste à suivre une courbe appelée *chemin central* jusqu’à atteindre la solution optimale. Le chemin central d’un programme linéaire $LP(A, b, c) \equiv \min\{c \cdot x \mid Ax \leq b, x \geq 0\}$ est défini comme l’ensemble des solutions optimales (x^μ, w^μ) des problèmes à barrière logarithmique:

$$\begin{aligned} & \text{minimiser} && c \cdot x - \mu \left(\sum_{j=1}^n \log x_j + \sum_{i=1}^m \log w_i \right) \\ & \text{sous les contraintes} && Ax + w = b, \quad x > 0, \quad w > 0 \end{aligned}$$

Les performances d’un algorithme de point intérieur sont intimement liées à la forme du chemin central. En particulier, la courbure mesure de combien un chemin diffère d’une ligne droite. Intuitivement, un chemin central à forte courbure devrait être plus difficile à approximer par des segments de droites, ce qui suggère davantage d’itérations des algorithmes de points intérieurs. La courbure totale du chemin central a été étudiée par Dedieu, Malajovich et Shub [105] à travers le théorème de Bezout dans le cas multihomogène, et par De Loera, Sturmfels and Vinzant [104] à l’aide de la théorie des matroïdes. Ces deux travaux fournissent une borne supérieure en $O(n)$ sur la courbure totale moyenne sur l’ensemble des régions formées par l’arrangement d’hyperplans en dimension n . Le cube de Klee-Minty redondant de [111] et le “serpent” de [110] sont des instances qui montrent que la courbure totale peut être de l’ordre de $\Omega(m)$ pour un polytope défini par m inégalités.

Dans un travail de X. Allamigeon, P. Benchimol, S. Gaubert, and M. Joswig, nous avons étudié la tropicalisation du chemin central. Le *chemin central tropical* est défini comme la limite logarithmique des chemins centraux d’une famille paramétrique de programmes linéaires $LP(A(t), b(t), c(t))$, où les entrées $A_{ij}(t)$, $b_i(t)$ and $c_j(t)$ sont des fonctions définissables dans une structure o-minimale appelée *corps de Hardy*.

Une première contribution a été de fournir une caractérisation entièrement géométrique du chemin central tropical. Nous avons montré que le centre analytique est donné par le plus grand élément de l’ensemble des points tropicaux admissibles. De plus, tout point du chemin central tropical coïncide avec le plus grand élément de l’ensemble admissible tropical intersecté avec un ensemble de sous-niveau de la fonction de coût tropicale.

Grâce à cette caractérisation, nous avons réfuté l’analogie continue de la conjecture de Hirsch proposé par Deza, Terlaky et Zinchenko. l’analogie continue de la conjecture de Hirsch proposé par Deza, Terlaky et Zinchenko. Ainsi, nous avons construit une famille de programmes linéaires définis par $3r + 4$ inégalités in dimension $2r + 2$, où le chemin central a une courbure totale en $\Omega(2^r/r)$. Cette famille est obtenue en relevant des programmes linéaires tropicaux introduits par Bezem, Nieuwenhuis et Rodríguez-Carbonell [83] pour montrer qu’un algorithme de Butkovič and Zimmermann [88] a une complexité exponentielle. Leur chemin central tropical a une forme de courbe en escalier avec $\Omega(2^r)$ marches.

Ces résultats sont rassemblés dans le document [50]. Ils ont été présentés à la conférence [41].

English version

In optimization, path-following interior point methods are driven to an optimal solution along a trajectory called the central path. The *central path* of a linear program $\text{LP}(A, b, c) \equiv \min\{c \cdot x \mid Ax \leq b, x \geq 0\}$ is defined as the set of the optimal solutions (x^μ, w^μ) of the barrier problems:

$$\begin{aligned} & \text{minimize} && c \cdot x - \mu \left(\sum_{j=1}^n \log x_j + \sum_{i=1}^m \log w_i \right) \\ & \text{subject to} && Ax + w = b, \quad x > 0, \quad w > 0 \end{aligned}$$

The performance of an interior point method is tightly linked to the shape of its central path. In particular, the curvature measures how far a path differs from a straight line. Intuitively, a central path with high curvature should be harder to approximate with line segments, and thus this suggests more iterations of the interior point methods. The total curvature of the central path has been studied by Dedieu, Malajovich and Shub [105] via the multihomogeneous Bézout Theorem and by De Loera, Sturmfels and Vinzant [104] using matroid theory. These two papers provide an upper bound of $O(n)$ on the total curvature averaged over all regions of an arrangement of hyperplanes in dimension n . The redundant Klee-Minty cube of [111] and the “snake” in [110] are instances which show that the total curvature can be in $\Omega(m)$ for a polytope described by m inequalities. By analogy with the classical Hirsch conjecture, Deza, Terlaky and Zichencko [110] conjectured that $O(m)$ is also an upper bound for the total curvature.

In a work of X. Allamigeon, P. Benchimol, S. Gaubert, and M. Joswig, we have studied the tropicalization of the central path. The *tropical central path* is defined as the logarithmic limit of the central paths of a parametric family of linear programs $\text{LP}(A(t), b(t), c(t))$, where the entries $A_{ij}(t)$, $b_i(t)$ and $c_j(t)$ are definable functions in an o-minimal structure called the *Hardy field*.

A first contribution is to provide a purely geometric characterization of the tropical central path. We have shown that the tropical analytic center is the greatest element of the tropical feasible set. Moreover, any point of the tropical central path is the greatest element of the tropical feasible set intersected with a sublevel set of the tropical objective function.

Thanks to this characterization, we disprove the continuous analog of the Hirsch conjecture proposed by Deza, Terlaky and Zinchenko, by constructing a family of linear programs with $3r + 4$ inequalities in dimension $2r + 2$ where the central path has a total curvature in $\Omega(2^r/r)$. This family arises by lifting tropical linear programs introduced by Bezem, Nieuwenhuis and Rodríguez-Carbonell [83] to show that an algorithm of Butkovič and Zimmermann [88] has exponential running time. The tropical central path looks like a staircase shape with $\Omega(2^r)$ steps.

These results are gathered in the preprint [50]. They have been presented in the conference [41].

6.5. Algorithmes/Algorithms

6.5.1. Itération sur les politiques pour le contrôle stochastique et les jeux répétés à somme nulle/Policy iterations for stochastic control and repeated zero sum games

Participants: Marianne Akian, Stéphane Gaubert.

L’algorithme d’itération sur les politiques est bien connu pour résoudre efficacement les équations de la programmation dynamique associées à des problèmes de contrôle stochastique avec critère à horizon infini (Howard) ou ergodique (Howard, et Denardo et Fox). Il a aussi été développé dans le cas de jeux à deux joueurs et somme nulle actualisés (Denardo) ou ergodiques (Hoffman et Karp).

Des résultats récents de Ye ainsi que Hansen, Miltersen et Zwick montrent que l'algorithme d'itération sur les politiques, restreint à la classe des jeux à somme nulle (à 1 ou 2 joueurs) actualisés de facteur d'actualisation donné, est fortement polynomial. Dans [58], on montre que ceci est le cas aussi pour l'algorithme d'itération sur les politiques pour les jeux à somme nulle et paiement moyen, restreint à la classe des jeux qui ont un temps moyen de retour ou d'arrivée à un état donné borné. La preuve utilise des techniques de théorie de Perron-Frobenius non-linéaire, permettant de ramener le problème à paiement moyen à un problème actualisé (de facteur d'actualisation dépendant de l'état et des actions). La même technique permet aussi de traiter le cas de jeux à somme nulle actualisés dont le facteur d'actualisation peut dépendre de l'état et des actions et prendre éventuellement des valeurs supérieures à 1. Récemment, on a montré que la borne pour le cas des jeux à somme nulle et paiement moyen s'applique aussi au cas des jeux actualisés de facteur d'actualisation constant [31], [32], [45]. Ce dernier résultat est inspiré par des résultats récents de Post et Ye et de Scherrer concernant les algorithmes du simplexe et d'itération sur les politiques pour les problèmes de contrôle optimal (ou jeux à 1 joueur).

English version

Policy iteration is a powerful and well known algorithm to solve the dynamic programming equation associated to stochastic control (one player game) problems with infinite horizon criterion (Howard) or ergodic criterion (Howard and Denardo and Fox). It has also been developed in the case of zero-sum two player games, either in discounted case (Denardo) or the ergodic one (Hoffman et Karp).

Recent results of Ye and Hansen, Miltersen and Zwick show that policy iteration for one or two player (perfect information) zero-sum stochastic games, restricted to instances with a fixed discount rate, is strongly polynomial. In [58], we show that policy iteration for mean-payoff zero-sum stochastic games is also strongly polynomial when restricted to instances with bounded first mean return time to a given state. The proof is based on methods of nonlinear Perron-Frobenius theory, allowing us to reduce the mean-payoff problem to a discounted problem with state dependent discount rate. Our analysis also shows that policy iteration remains strongly polynomial for discounted problems in which the discount rate can be state dependent (and even negative) at certain states, provided that the spectral radii of the nonnegative matrices associated to all strategies are bounded from above by a fixed constant strictly less than 1. Recently, we have proved that the bound for the case of mean-payoff zero-sum stochastic two-player games also holds for discounted games with a constant discount factor [31], [32], [45]. The latter result was inspired by recent results of Post and Ye, and Scherrer, concerning simplex and policy iteration algorithms for Markov decision processes (1 player games).

6.5.2. Algorithmique des polyèdres tropicaux/Algorithmics of tropical polyhedra

Participants: Xavier Allamigeon, Pascal Benchimol, Stéphane Gaubert, Eric Goubault [CEA], Michael Joswig [TU Berlin].

X. Allamigeon, S. Gaubert, et E. Goubault, ont développé dans [70], [72] plusieurs algorithmes permettant de manipuler des polyèdres tropicaux. Ceux-ci correspondent aux travaux décrits dans §6.3.1. Ils permettent notamment de déterminer les sommets et rayons extrêmes d'un polyèdre tropical défini comme intersection de demi-espaces, ou inversement, de calculer une représentation externe à partir d'un ensemble de générateurs. Ces algorithmes sont implémentés la bibliothèque TPLib (voir §5.3).

Dans un travail de X. Allamigeon, P. Benchimol, S. Gaubert et M. Joswig [51], nous avons défini un analogue tropical de l'algorithme du simplexe qui permet de résoudre les problèmes de *programmation linéaire tropicale*, i.e.

$$\begin{aligned} & \text{minimiser} && \max_{1 \leq j \leq n} c_j + x_j \\ & \text{sous les contraintes} && \max \left(\max_{1 \leq j \leq n} (a_{ij}^+ + x_j), b_i^+ \right) \geq \max \left(\max_{1 \leq j \leq n} (a_{ij}^- + x_j), b_i^- \right), \quad i = 1, \dots, m \\ & && x \in (\mathbb{R} \cup \{-\infty\})^n \end{aligned} \quad (6)$$

où les entrées du programme a_{ij}^\pm, b_i^\pm, c_j sont à valeur dans $\mathbb{R} \cup \{-\infty\}$. Ces problèmes sont intimement liés à la résolution de jeux répétés à somme nulle, puisque résoudre un jeux à paiement moyen déterministe est équivalent à déterminer si un problème de programmation linéaire admet un point réalisable [59].

Comme son homologue usuel, le simplexe tropical pivote entre des points de base (tropicaux), jusqu'à atteindre l'optimum du programme linéaire. La différence fondamentale avec l'algorithme du simplexe classique est que le pivotage est réalisé de manière purement combinatoire, en s'appuyant sur des descriptions locales du polyèdre tropical défini par les contraintes à l'aide d'(hyper)graphes orientés. Ceci nous a permis de prouver que *l'étape de pivotage (incluant le calcul des coûts réduits) a la même complexité en temps que dans l'algorithme classique, i.e. $O(n(m+n))$* . Ceci est d'autant plus inattendu que la structure des arêtes tropicales entre deux points de base sont géométriquement plus complexes (elles sont constituées de plusieurs segments de droite, jusqu'à n).

Le simplexe tropical a la propriété d'être fortement corrélé avec l'algorithme du simplexe classique. Grâce au principe de Tarski, le simplexe usuel peut être transposé tel quel sur des programmes linéaires dont les coefficients en entrée sont non plus des réels, mais sur le corps $\mathbb{R}\{\{t\}\}$ des séries de Puiseux généralisées en une certaine indéterminée t , i.e. des objets de la forme :

$$c_{\alpha_1} t^{\alpha_1} + c_{\alpha_2} t^{\alpha_2} + \dots \quad (7)$$

où les α_i sont des réels, les coefficients c_{α_i} sont des réels non-nuls, et où la séquence des $\alpha_1, \alpha_2, \dots$ est strictement croissante et soit finie, soit non-bornée. L'opposé du plus petit exposant de la série, $-\alpha_1$, est appelé *valuation* de la série. Un programme linéaire tropical est dit *relevé* en un problème linéaire sur $\mathbb{R}\{\{t\}\}$, si la valuation des coefficients en entrée de ce dernier sont égaux aux coefficients du problème tropical. Dans nos travaux, nous avons établi la correspondance suivante entre le simplexe usuel et le simplexe tropical : *pour tout programme linéaire tropical générique, l'algorithme du simplexe tropical trace l'image par la valuation du chemin sur l'algorithme du simplexe usuel sur n'importe quel relèvement du programme tropical dans $\mathbb{R}\{\{t\}\}$* .

Les résultats présentés ci-dessus sont rassemblés dans l'article [51]. Ils ont fait l'objet de plusieurs présentations en conférence [67], [68][27].

Ces résultats ouvrent la possibilité de relier la complexité du l'algorithme du simplexe usuel avec celles des jeux déterministes. Pour ces derniers, on sait seulement que leur résolution est dans la classe de complexité $NP \cap coNP$, et on ignore s'il existe un algorithme de complexité polynomiale. De façon similaire, on ne sait pas caractériser de façon précise la complexité de l'algorithme du simplexe usuel. Celle-ci dépend fortement de la règle de pivotage utilisée, et il existe des problèmes sur lesquelles de nombreuses règles de pivotage ont une complexité exponentielle. L'existence d'une règle de pivotage qui permettrait au simplexe de terminer en temps polynomial sur n'importe quelle instance est encore aujourd'hui une question ouverte.

Dans un deuxième travail, nous avons relié les deux problèmes ouverts précédents, grâce à l'algorithme du simplexe tropical. Nous avons en effet exhibé une classe de règles de pivotage, dites *combinatoires*, et avons montré qu'elles satisfont la propriété suivante : *s'il existe une règle de pivotage combinatoire qui permet de résoudre tout problème de programmation linéaire usuel en temps polynomial, alors on peut résoudre les jeux à paiement moyen en temps (fortement) polynomial*. Le terme *combinatoire* fait référence au fait que la règle est définie en fonction du signe des mineurs de la matrice des coefficients du problème linéaire. Ce résultat est décrit dans l'article [49], et a été présenté dans plusieurs conférences [39], [40].

Enfin, dans un travail de X. Allamigeon, P. Benchimol et S. Gaubert [26], nous avons étendu les résultats aux règles de pivotage *semi-algébriques*, classe incluant la règle dite du *shadow-vertex*. Celle-ci est connue pour avoir fourni plusieurs bornes de complexité moyenne et lisse sur l'algorithme du simplexe. Nous avons donc tropicalisé l'algorithme du simplexe shadow-vertex, et nous avons montré que cet algorithme permet de résoudre les jeux à paiement moyen en temps polynomial en moyenne.

English version

X. Allamigeon, S. Gaubert, and E. Goubault, have developed in [70], [72] algorithms allowing one to manipulate tropical polyhedra. They correspond to the contributions described in §6.3.1. In particular, they can be used to determine the vertices and extreme rays of a tropical polyhedron defined as the intersection of half-spaces, or inversely, to compute an external description from a set of generators. These algorithms are implemented in the library TPLib (see §5.3).

In an ongoing work of X. Allamigeon, P. Benchimol, S. Gaubert and M. Joswig, we introduced a tropical analogue of the simplex algorithm, allowing one to solve problems of *tropical linear programming*, which are of the form (13), where the coefficients of the program, a_{ij}^\pm, b_i^\pm, c_j take their values in the max-plus semiring $\mathbb{R} \cup \{-\infty\}$. These problems are closely related to mean payoff games, as solving a game of this kind is equivalent to determine whether a tropical linear program admits a feasible point [59].

Like the classical simplex algorithm, the tropical simplex algorithm performs pivoting operations between basis points, until it reaches the optimum. The main discrepancy with the classical algorithm is that the pivoting is now a purely combinatorial operation, which is performed by using a local description of the polyhedron by a directed hypergraph. This allowed us to show that *a tropical pivoting step (including computing reduced costs) has the same complexity as in the classical simplex algorithm, i.e. $O(n(m+n))$* . This is all the more surprising as the tropical edge between two given points has a geometrically more complex structure in the tropical case (it is constituted of up to n ordinary line segments).

The tropical simplex algorithm turns out to be closely related to the classical one. Thanks to Tarski's principle, the latter is also valid for linear programs over the field $\mathbb{R}\{\{t\}\}$ of generalized Puiseux series in an indeterminate t . These series are of the form (14), where the α_i are real numbers, the coefficients c_{α_i} are non-zero reals, and the sequence $\alpha_1, \alpha_2, \dots$ is strictly increasing and either finite or unbounded. The opposite of the smallest exponent of the series, $-\alpha_1$, is called *valuation*. A tropical linear program is said to be *lifted* to a linear program over $\mathbb{R}\{\{t\}\}$ if the valuation of the coefficients of the latter are sent to the coefficients of the former by the valuation. We showed the following relation between the classical simplex algorithm and its tropical analogue: *for all generic tropical linear program, the tropical simplex algorithm computes the image by the valuation of the path of the classical simplex algorithm, applied to any lift in $\mathbb{R}\{\{t\}\}$ of the original program*.

These results are gathered in the article [51]. They have been presented in several conferences [67], [68][27].

They allow one to relate the complexity of the classical simplex algorithm with the complexity of mean payoff games. The latter is unsettled, these games are known to be in the class $\text{NP} \cap \text{coNP}$ but it is not known whether they can be solved in polynomial time. Basic complexity issues regarding the classical simplex algorithm are also unsettled: its execution time depends on the pivoting rule, and many pivoting rules have been shown to have exponential worst case behaviors. The existence of a pivoting rule leading the simplex to terminate in polynomial time is still an open question. In a second work, we related these two open questions, via the tropical simplex algorithm. We identified a class of pivoting rules, which are said to be *combinatorial*, and show that they have the following property: *if there is a combinatorial pivoting rule allowing one to solve every classical linear programming problem in polynomial time, then, mean payoff games can be solved in (strongly) polynomial time*. By *combinatorial*, we mean that the rule depends only of the coefficients of the system through the signs of minors of the coefficients matrix. This result is given in the article [49]. It has been presented to the conferences [39], [40].

Finally, in a work of X. Allamigeon, P. Benchimol and S. Gaubert [26], we extended the latter results to *semi-algebraic* pivoting rules, which include the so-called *shadow-vertex* rule. This rule has been exploited in the literature to establish several average-case and smooth complexity bounds on the simplex algorithm. We tropicalized the shadow-vertex simplex algorithm, and showed that it solves mean payoff games in polynomial time on average.

6.5.3. Problèmes d'accessibilité dans les hypergraphes orientés et leur complexité/Reachability problems in directed hypergraphs and their complexity

Participant: Xavier Allamigeon.

Les hypergraphes orientés sont une généralisation des graphes orientés, dans lesquelles chaque arc relie un ensemble de sommets à un autre. Ils jouent un rôle important dans les travaux récents sur la convexité tropicale (voir §6.3.1), puisqu'ils offrent une représentation naturelle des cônes définis sur le sous-semi-anneau booléen $\mathbb{B} = \{-\infty, 0\}$.

Dans un travail de X. Allamigeon [66], on étudie la complexité de problèmes d'accessibilité sur les hypergraphes orientés. Nous introduisons un algorithme de complexité presque linéaire permettant de déterminer les composantes fortement connexes terminales (qui n'accèdent à aucune autre composante si ce n'est elles-mêmes) d'un hypergraphe.

Nous établissons également une borne inférieure sur-linéaire sur la taille de la réduction transitive de la relation d'accessibilité dans les hypergraphes. Cela indique que la relation d'accessibilité dans les hypergraphes orientés est combinatoirement plus complexe que celle des graphes orientés. Cela suggère aussi que des problèmes comme le calcul des composantes fortement connexes est plus difficile sur les hypergraphes que sur les graphes. Nous mettons d'ailleurs en évidence une réduction en temps linéaire du problème du calcul des ensembles minimaux dans une famille d'ensembles donnée, vers le problème du calcul de toutes les composantes fortement connexes d'un hypergraphe. Le problème du calcul des ensembles minimaux a été largement étudié dans la littérature [166], [185], [184], [167], [168], [169], [115], [80], et aucune algorithme en temps linéaire n'est connu à ce jour.

English version

Directed hypergraphs are a generalization of directed graphs, in which the tail and the head of the arcs are sets of vertices. It appears that they play an important role in the recent works on tropical convexity (see §6.3.1), since they offer a natural representation of cones defined over the boolean sub-semiring $\mathbb{B} = \{-\infty, 0\}$.

In a work of X. Allamigeon [66], we study the complexity of reachability problems on directed hypergraphs. We introduce an almost linear-time algorithm allowing to determine the terminal strongly connected components (a component is said to be *terminal* when no other component is reachable from it).

We also establish a super-linear lower bound over the size of the transitive reduction of the reachability relation in directed hypergraphs. This indicates that the reachability relation is combinatorially more complex in directed hypergraphs than in directed graphs. This also suggests that reachability problems such as computing all strongly connected components are likely to be harder in hypergraphs than in graphs. Besides, we show that the minimal set problem can be reduced in linear time to the problem of computing all strongly connected components in hypergraphs. The former problem consists in finding all minimal sets among a given family of sets. It has been well studied in the literature [166], [185], [184], [167], [168], [169], [115], [80], and no linear time algorithm is known.

6.5.4. Approximation max-plus de fonctions valeurs et équations de Riccati généralisées/Max-plus approximation of value functions and generalized Riccati equations

Participants: Stéphane Gaubert, Zheng Qu.

Les méthodes d'approximation max-plus conduisent à approcher la fonction valeur d'un problème de contrôle ou de jeux par un supremum d'un nombre fini de formes quadratiques, voir notamment [126]. On s'intéresse ici à l'analyse théorique (complexité) ainsi qu'à l'amélioration de ces méthodes. Dans certains cas, ces formes quadratiques sont propagées par des flots d'équations de Riccati généralisées. Afin d'effectuer des analyses d'erreur, on exploite les propriétés de contraction du flot de Riccati pour certaines métriques connues sur le cône des matrices positives, et en particulier pour la métrique de Thompson. Celle-ci n'est rien d'autre que $d_T(A, B) = \|\log \text{spec}(A^{-1}B)\|_\infty$, où spec désigne la suite des valeurs propres d'une matrice, et \log s'entend composante par composante.

Ceci nous a amené à étudier le problème général du calcul du taux de contraction d'un flot monotone sur un cône, pour la métrique de Thompson. En effet, les propriétés de contraction de l'équation de Riccati standard sont connues (résultats de Bougerol pour la métrique Riemannienne invariante, et de Wojtowski pour

la métrique de Thompson), mais les techniques de preuve employées dans ce cadre (semigroupes de matrices symplectiques) ne s'étendent pas aux équations généralisées.

On donne dans [16] une formule explicite générale pour le taux de contraction pour la métrique de Thompson d'un flot monotone, faisant seulement intervenir le générateur du flot et sa dérivée. On a notamment appliqué ce résultat à une équation de Riccati généralisée associée à des problèmes de contrôle stochastique avec critère quadratique, dans lesquels la dynamique comporte un terme bilinéaire en le contrôle et le bruit. On a montré dans ce cas que la métrique de Thompson est la seule métrique de Finsler invariante pour laquelle le flot est nonexpansif, et l'on a caractérisé la constante de contraction locale.

Une application de ces résultats de contraction à l'analyse d'une méthode de réduction de la malédiction de la dimension, dûe à McEneaney, a été donnée dans [22].

Une nouvelle méthode numérique max-plus, de nature randomisée, a été introduite dans [30], elle fait apparaître de très fortes accélérations par rapport aux méthodes précédentes.

La question de l'émondage des représentations max-plus a été abordée dans [29], où il est montré qu'une classe de relaxations convexes introduites par Sridharan et al. pour traiter numériquement un problème de contrôle quantique sont en fait exactes (pas de saut de relaxation).

English version

The max-plus methods lead to approach the value function of an optimal control or zero-sum game problem by a supremum of a finite number of quadratic forms, see in particular [126]. We are interested here in the theoretical analysis (complexity) of this class of methods, as well as of their improvement. In certain cases, the quadratic forms are propagated by the flows of generalized Riccati equations. In order to perform an error analysis, we need to use some contraction properties of the Riccati flow, for certain known metrics on the space of positive matrices, like Thompson's metric. The latter is nothing but $d_T(A, B) = \|\log \text{spec}(A^{-1}B)\|_\infty$, where spec denotes the sequence of eigenvalues of a matrix, and \log is understood entrywise.

This led us to study the general problem of computing the contraction rate of an order-preserving flow on a cone, with respect to Thompson's metric. Indeed, the contraction properties of the standard Riccati flow are known (theorem of Bougerol for the invariant Riemannian metric, of Wojtowski for the Thompson's metric), but the proof of these properties (based on symplectic semigroups) does not carry over to generalized Riccati equations.

We gave in [16] a general explicit formula for the contraction rate with respect to Thompson's metric of an order-preserving flow, involving only the generator of the flow and its derivative. We applied in particular this result to a generalized Riccati equation, associated to stochastic optimal control problems with a quadratic cost and a bilinear dynamics (presence of a bilinear term between the control and the noise). We showed that in this case, the Thompson's metric is the only invariant Finsler metric in which the generalized Riccati flow is nonexpansive, and we characterized the local contraction rate of this flow.

Z. Qu has applied these results in [22] to the analysis of a method of reduction of the curse of dimensionality, introduced by McEneaney.

A new max-plus numerical method, of a randomized nature, has been introduced in [30]. It shows an important speedup by comparison with earlier methods.

The question of trimming max-plus representations was dealt with in [29]. It is shown there that a class of convex relaxations introduced Sridharan et al. to solve numerically some quantum control problem is exact.

6.5.5. Approximation probabiliste d'équations d'Hamilton-Jacobi-Bellman et itération sur les politiques

Participants: Marianne Akian, Eric Fodjo.

La thèse d'Eric Fodjo traite de problèmes de contrôle stochastique (de diffusions) avec critère à horizon infini actualisé ou arrêté, ou moyen en temps long, issus en particulier de problèmes de gestion de portefeuille avec coûts de transaction. La programmation dynamique conduit à une équation aux dérivées partielles d'Hamilton-Jacobi-Bellman, sur un espace de dimension au moins égale au nombre d'actifs risqués. La malédiction de la dimension ne permet pas de traiter numériquement ces équations en dimension grande (supérieure à 5). On se propose d'aborder ces problèmes avec des méthodes numériques associant itération sur les politiques, discrétisations probabilistes, et discrétisations max-plus, afin d'essayer de monter plus en dimension. Une autre piste est de remplacer l'itération sur les politiques par une approximation par des problèmes avec commutations optimales. Ces méthodes devraient aussi s'appliquer au cas de problèmes à horizon fini.

English version

The PhD thesis of Eric Fodjo concerns stochastic control problems with long term discounted or stopped payoff, or with mean-payoff in time, obtained in particular in the modelisation of portfolio selection with transaction costs. The dynamic programming method leads to a Hamilton-Jacobi-Bellman partial differential equation, on a space with a dimension at least equal to the number of risky assets. Curse of dimensionality does not allow one to solve numerically these equations for a large dimension (greater to 5). We propose to tackle these problems with numerical methods combining policy iterations, probabilistic discretisations, max-plus discretisations, in order to increase the possible dimension. Another solution is to replace policy iterations by an approximation with optimal switching problems. These methods should also be useful for finite horizon problems.

6.6. Applications

6.6.1. Introduction

Nous présentons maintenant plusieurs travaux de nature appliquée, touchant à des domaines variés, dans lesquels nous exploitons certaines des techniques mathématiques présentées précédemment, et particulièrement celles qui relèvent de la théorie de Perron-Frobenius non-linéaire et de la convexité tropicale. Ces applications utilisent aussi des techniques d'algèbre linéaire ou d'optimisation convexe.

English version

In this section, we describe several applied works in which we use some of the theoretical tools developed by the team, including non-linear Perron-Frobenius theory and tropical convexity. Some of these applications also make an intensive use of linear algebraic and convex programming methods.

6.6.2. Optimisation de la croissance de populations/Optimizing population growth

Participants: Vincent Calvez [ENS Lyon et Inria, NUMED], Pierre Gabriel [UVSQ], Stéphane Gaubert.

On s'intéresse dans [28] à l'optimisation du taux de croissance d'une population, représentée par un système dynamique $\dot{x}(t) = M(t)x(t)$, où la matrice $M(t)$ appartient à un ensemble compact de matrices de Metzler irréductibles. Ceci est motivé par un problème de biologie mathématique (modélisation de processus de croissance-fragmentation et protocole PMCA). Nous montrons que le taux de croissance est donné par la valeur propre non-linéaire d'un analogue max-plus de l'opérateur de Ruelle-Perron-Frobenius, ou de manière équivalente, par la constante ergodique d'une EDP d'Hamilton-Jacobi, dont les solutions et sous-solutions fournissent respectivement des normes de Barabanov et des normes extrémales. Nous exploitons les propriétés de contraction des flots monotones, relativement à la métrique projective de Hilbert, pour démontrer que le vecteur propre non-linéaire, qui correspond à une solution "KAM faible" de l'équation d'Hamilton-Jacobi, a bien une solution. Des exemples en petite dimension sont discutés, montrant en particulier que le contrôle optimal peut produire un cycle limite.

English version

We study in [28] a growth maximization problem for a continuous time positive linear system with switches. More precisely, we consider a dynamical system $\dot{x}(t) = M(t)x(t)$, where the matrix $M(t)$ must be chosen in a compact set of irreducible Metzler matrices. This is motivated by a problem of mathematical biology (modeling growth-fragmentation processes and the PMCA protocol). We show that the growth rate is determined by the non-linear eigenvalue of a max-plus analogue of the Ruelle-Perron-Frobenius operator, or equivalently, by the ergodic constant of a Hamilton-Jacobi (HJ) partial differential equation, the solutions or subsolutions of which yield Barabanov and extremal norms, respectively. We exploit contraction properties of order preserving flows, with respect to Hilbert's projective metric, to show that the non-linear eigenvector of the operator, or the "weak KAM" solution of the HJ equation, does exist. Low dimensional examples are presented, showing that the optimal control can lead to a limit cycle.

6.6.3. Preuve formelle d'inégalités non-linéaires/Formal proofs of non-linear inequalities

Participants: Xavier Allamigeon, Stéphane Gaubert, Victor Magron, Benjamin Werner [LIX].

La thèse de Victor Magron [153], dirigée par Benjamin Werner, codirigée par Stéphane Gaubert et Xavier Allamigeon, a porté sur la certification de bornes inférieures de fonctions multivariées à valeurs réelles, définies par des expressions semi-algébriques ou transcendantales, et sur la preuve de validité de celles-ci au moyen de certificats dans l'assistant de preuves Coq.

De nombreuses inégalités de cette nature apparaissent notamment dans la preuve par Thomas Hales de la conjecture de Kepler. Voici un exemple typique d'inégalité à prouver.

LEMME 9922699028 FLYSPECK. Soit K , $\Delta\mathbf{x}$, l , t et f définis comme suit:

$$\begin{aligned} K &:= [4, 6.3504]^3 \times [6.3504, 8] \times [4, 6.3504]^2, \\ \Delta\mathbf{x} &:= x_1x_4(-x_1 + x_2 + x_3 - x_4 + x_5 + x_6) \\ &\quad + x_2x_5(x_1 - x_2 + x_3 + x_4 - x_5 + x_6) \\ &\quad + x_3x_6(x_1 + x_2 - x_3 + x_4 + x_5 - x_6) \\ &\quad - x_2x_3x_4 - x_1x_3x_5 - x_1x_2x_6 - x_4x_5x_6, \\ l(\mathbf{x}) &:= -\pi/2 + 1.6294 - 0.2213(\sqrt{x_2} + \sqrt{x_3} + \sqrt{x_5} + \sqrt{x_6} - 8.0) \\ &\quad + 0.913(\sqrt{x_4} - 2.52) + 0.728(\sqrt{x_1} - 2.0), \\ t(\mathbf{x}) &:= \arctan \frac{\partial_4 \Delta\mathbf{x}}{\sqrt{4x_1 \Delta\mathbf{x}}}, \\ f(\mathbf{x}) &:= l(\mathbf{x}) + t(\mathbf{x}). \end{aligned}$$

Alors, $\forall \mathbf{x} \in K, f(\mathbf{x}) \geq 0$.

On s'est donc intéressé à des fonctions non-linéaires, faisant intervenir des opérations semi-algébriques ainsi que des fonctions transcendantales univariées (cos, arctan, exp, etc).

De manière classique, on peut approcher les fonctions transcendantales qui interviennent de la sorte par des polynômes, ce qui permet de se ramener à des problèmes d'optimisation semi-algébriques, que l'on peut résoudre par des techniques de sommes de carrés creuses conduisant à des problèmes SDP. Cependant, en pratique, cette approche est limitée par la taille des SDP à résoudre, qui croît rapidement avec le degré des approximations polynomiales.

Dans ce travail de thèse, on a développé une méthode alternative, qui consiste à borner certains des constituants de la fonction non-linéaire par des suprema de formes quadratiques dont les Hessiens sont judicieusement choisis. On reprend donc ici l'idée des approximations "max-plus" initialement introduites en contrôle optimal, en s'appuyant sur des techniques d'interprétation abstraite (généralisation non-linéaire de la méthode des gabarits de Manna et al.). Ainsi, on obtient une nouvelle technique d'optimisation globale, basée sur les gabarits, qui exploite à la fois la précision des sommes de carrés et la capacité de passage à l'échelle des méthodes d'abstraction.

L'implémentation de ces méthodes d'approximation a abouti à un outil logiciel : `NLCertify`. Cet outil génère des certificats à partir d'approximations semi-algébriques et de sommes de carrés. Son interface avec `Coq` permet de bénéficier de l'arithmétique certifiée disponible dans l'assistant de preuves, et ainsi d'obtenir des estimateurs et des bornes valides pour chaque approximation.

Les performances de cet outil de certification ont été démontrées sur divers problèmes d'optimisation globale ainsi que sur des inégalités essentiellement serrées qui interviennent dans la preuve de Hales (projet `Flyspeck`). Ce travail est exposé dans [73], [74] et [18], [19].

English version

The PhD work of Victor Magron [153], supervised by Benjamin Werner, and cosupervised by Stéphane Gaubert and Xavier Allamigeon, dealt with the certification of lower bounds for multivariate functions, defined by semi-algebraic or transcendental expressions, and their correctness proof through certificates checked in the `Coq` proof assistant.

Many inequalities of this kind appear in particular in the proof by Thomas Hales of Kepler's conjecture. Here is a typical example of inequality.

LEMMA 9922699028 FLYSPECK. *Let K , $\Delta\mathbf{x}$, l , t and f be defined as follows:*

$$\begin{aligned} K &:= [4, 6.3504]^3 \times [6.3504, 8] \times [4, 6.3504]^2, \\ \Delta\mathbf{x} &:= x_1x_4(-x_1 + x_2 + x_3 - x_4 + x_5 + x_6) \\ &\quad + x_2x_5(x_1 - x_2 + x_3 + x_4 - x_5 + x_6) \\ &\quad + x_3x_6(x_1 + x_2 - x_3 + x_4 + x_5 - x_6) \\ &\quad - x_2x_3x_4 - x_1x_3x_5 - x_1x_2x_6 - x_4x_5x_6, \\ l(\mathbf{x}) &:= -\pi/2 + 1.6294 - 0.2213(\sqrt{x_2} + \sqrt{x_3} + \sqrt{x_5} + \sqrt{x_6} - 8.0) \\ &\quad + 0.913(\sqrt{x_4} - 2.52) + 0.728(\sqrt{x_1} - 2.0), \\ t(\mathbf{x}) &:= \arctan \frac{\partial_4 \Delta\mathbf{x}}{\sqrt{4x_1 \Delta\mathbf{x}}}, \\ f(\mathbf{x}) &:= l(\mathbf{x}) + t(\mathbf{x}). \end{aligned}$$

Then, $\forall \mathbf{x} \in K$, $f(\mathbf{x}) \geq 0$.

Thus, we considered non-linear functions, defined in terms of semi-algebraic operations and univariate transcendental functions (cos, arctan, exp, etc).

Such transcendental functions can be classically approximated by polynomials, which leads to semi-algebraic optimization problems, which can be solved by sparse sum of squares techniques leading to SDP formulations. However, in practice, this approach is limited by the growth of the size of the SDP instances to be solved, which grows quickly with the degree of polynomial approximations.

In this PhD, we developed an alternative method, which consists in bounding some constituents of the non-linear function to be optimized by suprema of quadratic forms with well chosen Hessians. This is based on the idea of "maxplus approximation" initially introduced in optimal control, and also, on abstract interpretation (the template method introduced by Manna et al. in static analysis). In this way, we end up with a new global optimization technique, which takes advantage of the precision of sum of squares and of the scalability of abstraction methods.

These methods have been implemented in a software tool: `NLCertify`. This tool generates certificates from semi-algebraic and sum of square certificates. Its interface with `Coq` allows one to take benefit of the certified arithmetics available in this proof assistant, and so, to obtain estimators and valid bounds for each approximation.

The performances of this certification tool have been shown on several global optimization problems from the literature, as well as on essentially tight inequalities taken from Hales' proof (`Flyspeck` project).

This work is presented in [73], [74] and [18], [19].

6.6.4. *Vérification de systèmes temps-réels/Verification of real-time systems*

Participants: Xavier Allamigeon, Uli Fahrenberg [IRISA], Stéphane Gaubert, Ricardo Katz [Conicet], Axel Legay [IRISA].

Dans [152], Lu, Madsen, Milata, Ravn, Fahrenberg et Larsen ont montré que les polyèdres tropicaux peuvent être utilisés dans le cadre de l'analyse d'accessibilité d'automates temporisés. En effet, les polyèdres tropicaux expriment naturellement des invariants non-convexes, qui sont en fait des disjonctions d'invariants fournis par des DBM (*difference bound matrices*). A ce titre, les polyèdres tropicaux devraient permettre de réduire le nombre de disjonctions réalisées pendant l'analyse d'automates temporisés. Une limitation importante de cette approche est cependant que les polyèdres tropicaux sont topologiquement fermés, et qu'ils ne peuvent donc pas exprimer de contraintes d'inégalités strictes. Ces dernières sont néanmoins fondamentales dans l'analyse de systèmes temps-réels.

Nous avons donc développé dans [69] une généralisation des polyèdres tropicaux permettant d'exprimer des contraintes mixtes, *i.e.* strictes ou larges. Notre approche repose sur l'utilisation d'inégalités tropicales linéaires à coefficients dans un (quotient du) semi-anneau de germes affines. Afin de réaliser des opérations sur cette nouvelle classe de polyèdres tropicaux, nous avons défini deux nouveaux algorithmes. Le premier est un analogue tropical de l'élimination de Fourier-Motzkin. Celle-ci s'applique plus généralement à des systèmes d'inégalités linéaires sur des semi-anneaux idempotents et totalement ordonnés. Le second algorithme permet de tester si un système de contraintes mixtes admet une solution. Nous montrons en effet que ce problème est équivalent en temps polynomial à la résolution d'un problème de jeux déterministes à somme nulle. Ces deux contributions nous permettent de définir les primitives requises pour l'analyse d'accessibilité d'automates temporisés.

English version

Lu, Madsen, Milata, Ravn, Fahrenberg and Larsen have shown in [152] that tropical polyhedra can be applied to the reachability analysis of timed automata. Indeed, tropical polyhedra naturally express non-convex invariants, which correspond to disjunctions of invariants provided by DBM (*difference bound matrices*). Consequently, tropical polyhedra should allow to reduce the number of disjunctions arising during the analysis of timed automata. An important limitation of this approach is that tropical polyhedra are topologically closed, and thus they cannot express strict inequality constraints. However, such constraints plays an important role in the analysis of real-time systems.

As a result, we have developed in [69] a generalization of tropical polyhedra, in order to express mixed constraints, *i.e.* strict or loose ones. Our approach relies on tropical linear inequalities with coefficients in a (quotient of) the semiring of affine germs. In order to perform operations on this new class of polyhedra, we have introduced two new algorithms. The first one is a tropical analog of Fourier-Motzkin elimination. In fact, it applies more generally to systems of linear inequalities over totally ordered and idempotent semirings. The second algorithm allows to test the feasibility of a mixed constraint system. We indeed show that this problem is polynomial-time equivalent to solving mean payoff games. These two contributions allow to define the primitives required by the reachability analysis of timed automata.

6.6.5. *Géométrie de l'ordre de Loewner et application au calcul d'invariants quadratiques en analyse statique de programme/Geometry of the Loewner order and application to the synthesis of quadratic invariants in static analysis of program*

Participants: Xavier Allamigeon, Stéphane Gaubert, Éric Goubault [LIX], Sylvie Putot [LIX], Nikolas Stott.

Le stage de recherche de l'École des Mines de Nikolas Stott a porté sur la caractérisation de l'ensemble des majorants minimaux de deux matrices symétriques, relativement à l'ordre de Loewner, et sur l'application de cette caractérisation à la synthèse d'invariants quadratiques en analyse statique de programme.

English version

The research internship of “École des Mines” made by Nikolas Stott dealt with the characterization of the set of minimal upper bounds of two matrices with respect to Loewner order, motivated by the generation of quadratic invariants in static analysis of programs.

6.6.6. Optimisation de l’affectation temps réel des moyens de secours des pompiers/Optimization of the real time assignment of firemen vehicles

Participants: Marianne Akian, Xavier Allamigeon, Vianney Boeuf, Stéphane Gaubert, Stéphane Raclot [BSPP].

La thèse de Vianney Boeuf, qui a démarré en Septembre, est effectuée en partenariat avec la Brigade des Sapeurs Pompiers de Paris (BSPP). Elle est motivée par l’optimisation des moyens de secours, en incluant les questions de dimensionnement et d’affectation temps réel des moyens. On s’intéresse en particulier à l’affectation des engins et véhicules de secours, éventuellement empruntés à différentes casernes. Ce travail intervient en complément du travail de l’équipe au sein du projet ANR Democrite, qui porte sur l’évaluation du risque en milieu urbain.

English version

The PhD work of Vianney Boeuf started in September. It is carried out with the Brigade of Paris Firemen (BSPP). It is motivated by the issue of optimization of emergency resources, including the real time dynamic assignment of engines or emergency vehicles. This work is carried out in complement to the ANR project Democrite, dealing with risk evaluation in urban environment.

MCTAO Project-Team

6. New Results

6.1. Optimal control for quantum systems and NMR

Participants: Bernard Bonnard, Mathieu Claeys [Imperial College, UK], Olivier Cots, Thierry Combot, Pierre Martinon [project team COMMANDS], Alain Jacquemard [Université de Bourgogne, IMB].

- The contrast imaging problem in nuclear magnetic resonance can be modeled as a Mayer problem, in the terminology of optimal control. The candidates as minimizers are selected among a set of extremals, solutions of a Hamiltonian system given by the Pontryagin Maximum Principle; sufficient second order conditions are known; they form the geometric foundations of the **HAMPATH code** which combines shooting and continuation methods.

In [4], based on these theoretical studies, a thorough analysis of the case of deoxygenated/oxygenated blood samples is pursued, based on many numerical experiments.

- We initiated more than a year ago a program to compare and study the complementarities between these methods based on the Pontryagin Maximum Principle are known as indirect methods,
 - with the so-called direct methods where optimal control is seen as a generic optimization problem, as implemented in the **Bocop** software, developed in the COMMANDS project-team,
 - and with LMI techniques used to obtain global bounds on the extremum;
 this was naturally done in collaboration with Pierre Martinon, an important contributor to Bocop and with Mathieu Claeys (LAAS CNRS, a PhD student supervised by J.-B. Lasserre, now with Imperial College). The results are very promising, and there is a gain, numerically, in using both direct and indirect methods while working towards global optimality (in the contrast problem there are many local optima and the global optimality is a complicated issue). This is presented in [3].

This also led to use algebraic techniques to further analyse the equations and their dependence of the materials to be discriminated [10].

- For time minimal control of a linear spin system with Ising coupling (more complex than the model above), we also analysed *integrability* properties of extremal solutions of the Pontryagin Maximum Principle, in relation with conjugate and cut loci computations. Restricting to the case of three spins, as in [11], the problem is equivalent to analyze a family of almost-Riemannian metrics on the sphere S^2 , with Grushin equatorial singularity. The problem can be lifted into a SR-invariant problem on $SO(3)$, this leads to a complete understanding of the geometry of the problem and to an explicit parametrization of the extremals using an appropriate chart as well as elliptic functions. This approach is compared with the direct analysis of the Liouville metrics on the sphere where the parametrization of the extremals is obtained by computing a Liouville normal form. This is backed by an algebraic approach applying differential Galois theory to integrability.

6.2. Conjugate and cut loci computations and applications

Participants: Bernard Bonnard, Olivier Cots, Jean-Baptiste Caillaud, Alessio Figalli [Univ. of Texas at Austin, USA], Thomas Gallouët [MEPHYSTO project-team], Ludovic Rifford.

- Many optimal control problems from mechanics or quantum systems (see [11] and the last paragraph of section 6.1) lead to studying some kind of singular metrics, sometimes known as almost-Riemannian. This led us to consider, in [2], metrics on the two-sphere of revolution of the following kind: they are Riemannian on each open hemisphere whereas one term of the corresponding tensor becomes infinite on the equator. Length minimizing curves can be computed and structure results on the cut and conjugate loci given, extending those in [25]. These results rely on monotonicity and convexity properties of the quasi-period of the geodesics; such properties are studied on an example with elliptic transcendence. A suitable deformation of the round sphere allows to reinterpretate the equatorial singularity in terms of concentration of curvature and collapsing of the sphere.

- It is known that convexity of the injectivity domain (the boundary of which is sent by the exponential map to the first cut locus) and the “Ma–Trudinger–Wang condition” (an positivity condition on the Ma–Trudinger–Wang tensor) both play a very important role in the continuity of solutions of optimal transport problems. This led to study these properties on their own, and it is still an open question to decide under which conditions the latter implies the former. In [13], it is proved that the MTW condition implies the convexity of injectivity domains on a smooth nonfocal compact Riemannian manifold. This improves a previous result by Loeper and Villani.

6.3. Averaging in control and application to space mechanics

Participants: Bernard Bonnard, Helen-Clare Henninger, Jana Němcová [Institute of Chemical Tech, Prague, CZ], Jean-Baptiste Pomet, Jeremy Rouot.

As explained in sections 3.5 and 4.1, control problems where the non controlled system is conservative and the control effect is small compared to the free dynamics lead to computing an average system. This computation may be explicit or numerical.

Even though it will not be always the case that an explicit expression is available, it is interesting to study that case thoroughly.

- In [23], [24], a smooth Riemannian metric was introduced to describe the energy minimizing orbital transfer with low propulsion. We have pursued a study of its deformation due to the standard perturbations in space mechanics, e.g. oblate spheroid shape of the Earth and lunar attraction. In [12], using Hamiltonian formalism, we describe the effects of the perturbations on the orbital transfers and the deformation of the conjugate and cut loci of the original metric. This is done using averaging with respect to both the proper frequency of the space vehicle and the moon frequency.
- The average system has the advantage of being more controllable (it has new virtual controls), but often displays singularities that were not present in the original system. It is the case when minimum time is considered instead of the quadratic energy criterium. We are conducting an analysis of this average minimum time Hamiltonian flow.

In [6], we compare the two problems for planar transfers. While the energy case leads to analyze a 2D Riemannian metric using the standard tools of Riemannian geometry (curvature computations, geodesic convexity), the time minimal case is associated to a Finsler metric which is not smooth. Nevertheless a qualitative analysis of the geodesic flow is given in this article to describe the optimal transfers. In particular we prove geodesic convexity of the elliptic domain.

6.4. Applications of control methods to dynamical systems

Participants: Gonzalo Contreras, Alessio Figalli, Ayadi Lazrag, Ludovic Rifford, Raffael Ruggiero.

Ludovic Rifford and collaborators have been applying with success, techniques from geometric control theory to open problems in dynamical systems, mostly on genericity properties and using controllability methods to build suitable perturbations.

This has been applied to closing geodesics and weak-KAM theory [39], [38].

Ayadi Lazrag’s PhD also deals with such problems; applying techniques close to these in [61], he established a version of Francks’ lemma for geodesic flows; one goal is to apply this to persistence problems. The approach relies on control theory results, with order 2 conditions. See [14] and [15], where a non trivial conjecture on generic hyperbolicity of the so-called Aubry set of a Hamiltonian is solved on compact surfaces and in the C^2 topology (for genericity).

NECS Project-Team

6. New Results

6.1. Highlights of the Year

- C. Canudas de Wit serves as General Chair for the European Control Conference (ECC'14), Strasbourg, France, Jul. 2014 (<http://www.ecc14.eu/>).
- Launch of the SPEEDD EU FP7 project in Feb. 2014.
- Launch of the COMFORT project, which supports the associate Team between Inria project-team NeCS and the Berkeley University project PATH (<http://necs.inrialpes.fr/pages/projects/comfort.php>).
- Launch of the LOCATE-ME Persyval project (Apr. 2014 to Aug. 2015) in collaboration with the Tyrex team.
- The team has organized the Hycon2 Show day in May 2014 (<http://www.inria.fr/en/centre/grenoble/calendar/hycon2-show-day-traffic-modeling-estimation-and-control>).

6.2. Networked systems and graph analysis

6.2.1. *Distributed solution to the network reconstruction problem*

Participants: A. Kibangou [Contact person], F. Morbidi.

It has been recently shown in [45] that by collecting noise-contaminated time series generated by a coupled-oscillator system at each node of a network, it is possible to robustly reconstruct its topology, i.e. determine the graph Laplacian. Restricting ourselves to linear consensus dynamics over undirected communication networks. In [18], we have introduced a new dynamic average consensus least-squares algorithm to locally estimate these time series at each node, thus making the reconstruction process fully distributed and more easily applicable in the real world. We have also proposed a novel efficient method for separating the off-diagonal entries of the reconstructed Laplacian, and examined several concepts related to the trace of the dynamic correlation matrix of the coupled single integrators, which is a distinctive element of our network reconstruction method.

6.2.2. *Distributed estimation of Laplacian eigenvalues and network robustness assessment*

Participants: A. Kibangou [Contact person], T.-M. D. Tran, J. Hendrickx [Univ. Louvain-la-neuve].

As recently shown, Laplacian eigenvalues can be estimated by solving the factorization of the average consensus Matrix [46]. The problem was viewed as a constrained consensus optimization one. The main assumption was about the knowledge of the final consensus value. Indeed, estimation of the Laplacian eigenvalues can be carried out using measurements of the transient of the consensus protocol and the steady state (consensus value). In [34], we relaxed the assumptions by considering that the consensus value is only approximately known. We formulated a convex optimization, which allowed us to make use of recent well-known techniques and results dealing with convex optimization problem proposed in the literature (the Alternating Direction of Multipliers Method, ADMM), [40], [42]. Recently, we assumed that the consensus value is completely unknown and has to be found simultaneously with Laplacian eigenvalues. In such a case the problem becomes a convex combination problem where the cost function comprises two terms, one that is average consensus problem, and the rest is the consensus problem to estimate the Laplacian eigenvalues. The simulations indicate that the proposed algorithm is efficient enough to provide the nonzero distinct Laplacian eigenvalues with high accuracy. These eigenvalues are then used to assess the robustness of the graph by means of some spectral metrics, the number of spanning trees and the Kirchoff index precisely.

6.2.3. *Observability and privacy preserving features in consensus networks*

Participants: A. Kibangou [Contact person], C. Commault [Grenoble INP].

In [16], we have studied of observability in consensus networks modeled with strongly regular graphs or distance regular graphs. The first result consists in a Kalman-like simple algebraic criterion for observability in distance regular graphs. This criterion consists in evaluating the rank of a matrix built with the components of the Bose-Mesner algebra associated with the considered graph. Then, we have defined some bipartite graphs that capture the observability properties of the graph to be studied. In particular, we showed that necessary and sufficient observability conditions are given by the nullity of the so-called local bipartite observability graph (resp. local unfolded bipartite observability graph) for strongly regular graphs (resp. distance regular graphs). When the nullity cannot be derived directly from the structure of these bipartite graphs, the rank of the associated bi-adjacency matrix allows evaluating observability. Eventually, as a by-product of the main results we have shown that non-observability can be stated just by comparing the valency of the graph to be studied with a bound computed from the number of vertices of the graph and its diameter. Similarly non-observability can also be stated by evaluating the size of the maximum matching in the above mentioned bipartite graphs. Non-observability is strongly linked to privacy preserving feature of a given network. Indeed, when a node is neighborhood non-observable, it means that the data of the other nodes (excluding those of its neighborhood) cannot be retrieve from such a node. Therefore security efforts in order to preserve privacy of the entire network must be focused on nodes that are neighborhood-observable.

6.2.4. Average and parametric consensus

Participants: A. Kibangou [Contact person], F. Morbidi.

We have studied average consensus in wireless sensor networks with aim of providing a way to reach consensus in a finite number of steps [17]. In particular, we investigate the design of consensus protocols when, for security reasons for instance, the underlying graph is constrained to be strongly regular or distance regular. The proposed design method is based on parameters of the intersection array characterizing the underlying graph. With this protocol, at execution time, average consensus is achieved in a number of steps equal to the diameter of the graph, i.e. the smallest possible number of steps to achieve consensus. We have extended the parametric consensus protocol recently introduced by F. Morbidi, to more realistic agents modeled as double integrators and interacting over an undirected communication network. The stability properties of the new protocol in terms of the real parameter “s” are studied for some relevant graph topologies, and the connection with the notion of bipartite consensus is highlighted. The theory is illustrated with the help of two worked examples, dealing with the coordination of a team of quadrotor UAVs and with cooperative temperature measurement in an indoor environment [32].

6.3. Collaborative and distributed algorithms

6.3.1. Distributed computation methods for large-scale multidimensional data

Participants: A. Kibangou [Contact person], T.-M. D. Tran, A. de Almeida [UFC Brazil].

From Internet to large research infrastructures, the volume of data generated by our societies is continuously increasing. A deluge faced by the producers of these data as well as their users. The big data issue is a significant scientific challenge that requires deep investigations in both engineering and fundamental science. Low-rank matrix factorization has received a particular attention in recent years, since it is fundamental to a variety of mining tasks that are increasingly being applied to massive datasets. In large applications, matrix factorizations can involve matrices with billions of entries. At this massive scale, distributed algorithms for matrix factorization are essential to achieve reasonable performance [43]. However, in many disciplines, data inherently has more than two axes of variation and can be arranged as tensors (i.e. multi-way arrays). Computing tensor decompositions of multi-way datasets is particularly useful to extract hidden patterns and structure in data analytics problems. Specifically, CPD (Canonical Polyadic Decomposition) also known as PARAFAC (Parallel factor analysis) is an extension of a low rank matrix decomposition to tensors. In [26], we have introduced a fully distributed method to compute the CPD of a large-scale data tensor across a network of machines with limited computation resources. The proposed approach is based on collaboration between the machines in the network across the three modes of the data tensor. Such a multi-modal collaboration allows an essentially unique reconstruction of the factor matrices in an efficient way. We provide an analysis

of the computation and communication cost of the proposed scheme and address the problem of minimizing communication costs while maximizing the use of available computation resources.

6.3.2. Collaborative source seeking

Participants: C. Canudas de Wit [Contact person], R. Fabbiano, F. Garin, Y. Gaudfrin, J. Dumon.

The problem of source localization consists in finding, with one or several agents possibly cooperating with each other, the point or the spatial region from which a quantity of interest is being emitted. Source-seeking agents can be fixed sensors, that collect and exchange some information about the signal field and try to identify the position of the source (or the smallest region in which it is included), or moving devices equipped with one or more sensors, that physically reach the source in an individual or cooperative way. This research area is attracting a rapidly increasing interest, in particular in applications where the agents have limited or no position information and GPS navigation is not available, as in underwater navigation or in cave exploration: for instance, source localization is relevant to many applications of vapor emitting sources such as explosive detection, drug detection, sensing leakage or hazardous chemicals, pollution sensing and environmental studies. Other fields of interest are sound source localization, heat source localization and vent sources in underwater field. Techniques present in literature either are based on a specific knowledge of the solution of the diffusion process, or make use of an extremum-seeking approach, exciting the system with a periodic signal so as to explore the field and collect enough information to reconstruct the gradient of the quantity of interest. Our approach [13] lies in the computation of derivatives (potentially of any order) from Poisson integrals that, for isotropic diffusive source in steady-state, whose solution satisfies the Laplace equation, allows for a gradient search with a small computation load (derivatives are computed by integrals) and without requiring any knowledge of the closed-form solution, avoiding in the same time extremum-seeking oscillations; this has the additional advantage of an intrinsic high-frequency filtering, that makes the method robust to measurement noise. We also propose a distributed version of this algorithm [28], where agents communicate in order to reconstruct gradient information from local pointwise measurements, and a control law combines the two objectives of formation control (to have a circular formation, so that measurements are taken around circle) and gradient ascent (so as to move towards the source); differently from previous literature [41], the moving agents do not need to know their absolute position, but only relative bearing angle of their neighbours.

6.4. Sensor networks: estimation and data fusion

6.4.1. Data fusion approaches for motion capture by inertial and magnetic sensors

Participants: H. Fourati [Contact person], A. Makni, A. Kibangou.

The problem of rigid body attitude estimation under external acceleration from a small inertial/magnetic sensor module containing a triaxial gyroscope, accelerometer, and magnetometer is considered [15]. We are focused on two main challenges. The first one concerns the attitude estimation during dynamic conditions, in which external acceleration occurs [30]. Although external acceleration is one of the main source of loss of performance in attitude estimation methods, this problem has not been sufficiently addressed in the literature. A quaternion based adaptive Kalman filter (q-AKF) compensating external acceleration from the residual in the accelerometer is designed. At each step, the covariance matrix associated with the external acceleration is estimated to adaptively tune the filter gain. The second challenge deals with the energy consumption issue of gyroscope for a long-term battery life of Inertial Measurement Units (IMUs). We study the way to reduce the gyro measurement acquisition by switching on/off the sensor while maintaining acceptable attitude estimation. A smart detection approach is proposed to decide whether the body is in dynamic or static motion. The efficiency of the q-AKF is investigated through numerical simulations and experimental tests, under external acceleration and parsimonious use of gyroscope. This work is described in a submitted in IEEE/ASME Transactions on Mechatronics.

6.4.2. Pedestrian dead-reckoning navigation

Participant: H. Fourati [Contact person].

We propose a foot-mounted Zero Velocity Update (ZVU) aided Inertial Measurement Unit (IMU) filtering algorithm for pedestrian tracking in indoor environment. The algorithm outputs are the foot kinematic parameters, which include foot orientation, position, velocity, acceleration, and gait phase. The foot motion filtering algorithm incorporates methods for orientation estimation, gait detection, and position estimation. A novel Complementary Filter (CF) is introduced to better pre-process the sensor data from a foot-mounted IMU containing tri-axial angular rate sensors, accelerometers, and magnetometers and to estimate the foot orientation without resorting to GPS data. A gait detection is accomplished using a simple states detector that transitions between states based on acceleration measurements. Once foot orientation is computed, position estimates are obtained by using integrating acceleration and velocity data, which has been corrected at step stance phase for drift using an implemented ZVU algorithm, leading to a position accuracy improvement. We illustrate our findings experimentally by using of a commercial IMU during regular human walking trial in a typical public building. Experiment results show that the positioning approach achieves approximately a position accuracy less than 1 m and improves the performance regarding a previous work of literature [14].

6.4.3. Sensor placement of unreliable sensors

Participants: F. Garin [Contact person], P. Frasca [U. Twente], B. Gerencsér [U. Catholique de Louvain], J. Hendrickx [U. Louvain-la-neuve].

We consider problems in which sensors have to be deployed in a given environment in such a way to provide good coverage of it. It is clear that sensor failures may deteriorate the performance of the resulting sensor network. Then, it is also natural to ask if taking into account such uncertainties changes the coverage optimization problem and leads to a different optimal solution. For simplicity, we start considering a one-dimensional problem, where sensors are to be placed on a line in such a way to optimize the disk-coverage cost. The optimal solution for reliable sensors is simply an equally-spaced configuration of the sensors. If we allow that the sensors may fail to take or communicate their measurements, this solution may instead not be optimal. In our work, we assume that sensor can fail, independently and with a same failure probability, and we aim to minimize, in expectation, the largest distance between a point in the environment and an active sensor. Our first result states that the problem at hand is equivalent to a linear program, albeit with a number of variables growing exponentially with the number of sensors. This fact allows for a computational solution that is tractable if the number of sensors is not large. Secondly, we show that for large number of sensors n , the cost of the equispaced placement is asymptotically optimal, i.e., the ratio between its cost and the optimal cost tends to 1 when n grows. By contrast, we show in that a random sensor placement has an expected cost which is larger. This work has been presented at MTNS conference [35] and is described in a submitted journal paper (see <http://arxiv.org/abs/1404.7711>).

6.5. Control design and co-design

6.5.1. Energy-aware networked control

Participants: C. Canudas de Wit [Contact person], F. Garin, N. Cardoso de Castro, D. Quevedo [U. Newcastle].

We have considered an event-based approach to energy-efficient management of the radio chip in the sensor node of a wireless networked control system. Indeed the radio is the main energy consumer, and intermittent data transmission allows one to reduce the use of the radio. While the existing literature in the control community on event-based control only addresses policies using two radio modes (transmitting/sleep), our work follows some considerations on the radio chip modes well-known in the communication networks literature, and introduces various radio-modes: different ‘idle’ non-transmitting modes, where only part of the radio chip is switched off (thus consuming more energy than ‘sleep’, but allowing for faster transition to transmission), and various transmitting modes, with different power levels. We propose an event-based radio-mode switching policy, which allows to perform a trade-off between energy saving and performance of the control application; to this end, a switched model describes the system, taking into account control and communication. The optimal switching policy is computed using dynamic programming, considering a cost either over an infinite time-horizon (see [36]) or over a finite receding horizon (joint work with D. Quevedo, Univ. Newcastle, Australia, described in a paper in preparation).

6.5.2. Adaptive control strategy based reference model for spacecraft motion trajectory

Participants: H. Fourati [Contact person], Z. Samigulina [Kazakh National Technical University], O. Shirayeva [Institute of Informatics and Control Problems].

In aerospace field, the economic realization of a spacecraft is one of the main objectives which should be accomplished by conceiving the optimal propulsion system and the best control algorithms. Our work focuses on the development of a viable Adaptive Control Approach (ACA) for Spacecraft Motion Trajectory (SMT), see [19]. The proposed strategy involves the nonlinear mathematical model of SMT expressed in the central field, which is linearized by the Taylor expansion, and the second Lyapunov method to offer a high rate and unfailing performance in the functioning. The adaptive control system is composed of the cascade of adaptation loop and feedback control loop. When the spacecraft deviates from its reference trajectory model, the ACA acts on the control system to correct this deviation and follow the optimal reference trajectory. Therefore, when the states of the adjustable model are different from its reference values, then the error signal is provided as an input to the adaptation law, which contains the adaptation algorithm. The output will be the state variable feedback control matrix which will be used to calculate the new control law vector. The efficiencies of the linearization procedure and the control approach are theoretically investigated through some realistic simulations and tests under MATLAB. The steady state errors of control between the reference model and the adjustable model of SMT converge to zero. This work is described in [20].

6.5.3. Control design for hydro-electric power-plants

Participants: C. Canudas de Wit [Contact person], S. Gerwig, F. Garin, B. Sari [Alstom].

We have initiated a collaboration with Alstom on collaborative and resilient control of hydro-electric power-plants, with the CIFRE PhD thesis of Simon Gerwig. The first goal of this research is to improve performance of a hydro-electric power-plant outside its design operation conditions, by adaptive cancellation of oscillations that occur in such an operation range. Indeed, current operation of power-plants often requires to operate on a variety of conditions, often different from the ones initially considered when designing the plant. At off-design operation pressure, the hydraulic turbine exhibits a vortex rope below the runner. This vortex generates pressure fluctuations after the turbine and can excite the hydraulic pipes. Indeed the water is compressible and the pipe walls elastic, so the system can oscillate. The goal is to damp these pressure oscillations as they create vibrations in the system and can lead to damages. Our first contribution has been to model the effect of the vortex rope on the hydraulic system as an external perturbation source acting on pipes. The pipes themselves are described with equations taking into account water compressibility and pipe-wall elasticity. The resulting model is nonlinear with hyperbolic functions in the equations (analogous to high-frequency transmission lines), from which we obtain a suitably linearized model.

6.5.4. Controller for switched linear systems

Participants: H. Fourati [Contact person], Djamel. E. C. Belkhiat [U. Setif], D. Jabri [U. Setif].

We designed a robust output feedback tracking controller for a class of Switched Linear Systems (SLS) subject to external disturbances [23]. The proposed synthesis approach, based on a descriptor redundancy formulation, allows to avoid of the crossing terms appearance between the switched Proportional-Derivative (PD) controller's and the switched system's matrices. Using the multiple Lyapunov functional methods, a robust output feedback tracking performance has been formulated in terms of set of Linear Matrix Inequality (LMI). The effectiveness of the proposed synthesis procedure has been illustrated by a numerical example [24].

6.6. Transportation networks and vehicular systems

6.6.1. Traffic estimation and prediction

Participants: C. Canudas de Wit [Contact person], A. Kibangou, L. Leon Ojeda, F. Morbidi.

In the PhD thesis of Leon Ojeda, we have been concerned with the design of a methodology for the real-time multi-step ahead travel time forecasting using flow and speed measurements from an instrumented freeway. Two main methodologies have been considered. The first one, a signal-based, uses only speed measurements collected from the freeway, where a mean speed is assumed between two consecutive collection points. The travel time is forecasted using a noise Adaptive Kalman Filter (AKF) approach. The process noise statistics are computed using an online unbiased estimator, while the observations and their noise statistics are computed using the clustered historical traffic data. Forecasting problems are reformulated as filtering ones through the use of pseudo-observations built from historical data. The second one, a model-based, uses mainly traffic flow measurements. Its main appealing is the use of a mathematical model in order to reconstruct the internal state (density) in small road portions, and consequently exploits the relation between density and speed to forecast the travel time. The methodology uses only boundary conditions as inputs to a switched Luenberger state observer, based on the "Cell Transmission Model" (CTM), to estimate the road initial states. The boundary conditions are then forecasted using the AKF developed above. Consequently, the CTM model is run using the initial conditions and the forecasted boundaries in order to obtain the future evolution of densities, speeds, and finally travel time. The added innovation in this approach is the space discretization achieved: indeed, portions of the road, called "cells", can be chosen as small as desired and thus allow obtaining a finer tracking of speed variations. The developed methodologies were assessed using the city-lab GTL [31]. Features and activities of this platform are described in [39].

6.6.2. Traffic control

Participants: C. Canudas de Wit [Contact person], D. Pisarski.

The work was mainly focused on the final design of a distributed controller and its implementation to the model of the south ring of Grenoble in the context of the project Hycon2. For the sake of the controller design, a distributed optimal control method for balancing of freeway traffic density was studied. The optimization was performed in a distributed manner by utilizing the controllability properties of the freeway network represented by the Cell Transmission Model. By using these properties, the subsystems to be controlled by local ramp meters were identified. The optimization problem was then formulated as a non-cooperative Nash game. The game was solved by decomposing it into a set of two-players hierarchical and competitive games. The process of optimization employed the communication channels matching the switching structure of system interconnectivity. By defining the internal model for the boundary flows, local optimal control problems were efficiently solved by utilizing the method of Linear Quadratic Regulator. The developed control strategy was tested via numerical simulations on the macroscopic model in two scenarios for uniformly congested and transient traffic. The controller was also validated through a microscopic simulations with the use of Aimsun software. The controller was implemented through Matlab under which a relevant program simulating distributed architecture was designed. The controller was then plugged to the Aimsun micro-simulator. The simulated scenario was based on real traffic data collected from the south ring of Grenoble. Were examined both, the balancing metric (optimized) and a set of standard traffic metrics (not optimized). The results showed that the balancing has a positive impact on the traffic flow, in particular, by smoothing the vehicle dynamics, it can potentially increase the average velocity (and thus, reduce the travelling time) and reduce the fuel consumption (and related emissions). The proposed modular architecture enabled to perform the optimization for long freeway sections in the real-time.

6.6.3. Control of urban traffic networks

Participants: C. Canudas de Wit [Contact person], F. Garin, P. Grandinetti.

This work deals with efficient operation of urban traffic networks, by controlling traffic lights. A first contribution has been to devise a model for urban networks, based on the Cell-Transmission-Model adapted to signalized intersections, and then simplified with an average-based approximation. Then, based on this model, a control law has been designed, where the duty cycle of each traffic light is optimized in real time, globally considering the whole network. We have chosen a simple one-step-ahead optimization, which can be formulated as a linear program, thus resulting in simple and fast optimization. This work is part of the PhD thesis of Pietro Grandinetti.

6.6.4. Stability of Monotone Dynamical Flow Networks

Participants: E. Lovisari [Contact person], G. Como [U. Lund], K. Savla [U. of Southern California].

The stability properties of monotone dynamical flow networks are studied [22]. Demand and supply functions relate states and flows of the network, and the dynamics at junctions are subject to fixed turning rates. Our main result consists in the characterization of a stability region such that: If the inflow vector in the network lies strictly inside the stability region and a certain graph theoretical condition is satisfied, then a globally asymptotically stable equilibrium exists. In contrast, if the inflow vector lies strictly outside the region, then every trajectory grows unbounded in time. As a special case, our framework allows for the stability analysis of the Cell Transmission Model on networks with arbitrary topologies. These results extend and unify previous work by Gomes et al. on stability of the Cell Transmission Model on a line topology as well as that by the authors on throughput optimality in monotone dynamical flow networks.

6.6.5. Control of communicating vehicles in urban environment

Participants: C. Canudas de Wit [Contact person], G. de Nunzio.

The stability properties analysis of the Variable Length Model (proposed by Prof. Canudas de Wit in 2011), adapted to the urban environment was studied. It has been found that the canonical definition of Lyapunov stability for the equilibrium points does not hold for the system under analysis. A different approach for the analysis of the stability properties of the system has been introduced. Furthermore, an energy map of the equilibrium points has been obtained. Namely, a cost was associated with each feasible equilibrium point of the system, thus obtaining an assessment of the efficiency of any operation point of the system. A Variable-Speed-Limits tracking controller of the desired operation point (i.e. equilibrium) has been also devised, in order to simulate the response of the driver to the energy-efficient speed advisory. This work was submitted and accepted at the IEEE Conference on Decision and Control 2014, with the title "Urban Traffic Eco-Driving: Speed Advisory Tracking". A previous work on the steady-state analysis of the Variable Length Model in urban environment was carried out in [27]. The effort has been put also on the validation of the macroscopic model (i.e. the Variable Length Model), used for traffic evolution prediction and control synthesis. The validation procedure was run with a microscopic traffic simulator, and aims at proving that the evolution of the state of the mathematical model replicates accurately the true evolution of the traffic conditions. In particular, an important variable modeled by the system is the length of the congested area of the road section under analysis, which may be thought of as the queue length. It has been shown that the macroscopic model is able to depict the evolution in time of the queue length, with only a small error with respect to the real congestion simulated by the highly-detailed microscopic simulator. Furthermore, the validation process aims, not only at confirming the reliability of the dynamical model, but also the accuracy of the energy consumption model and the other macroscopic traffic performance metrics that have been defined in order to formulate the optimization problem. Within the COMFORT project exchange program, the work on bandwidth maximization on signalized arterials by introducing VSL as an additional degree of freedom, and by considering the energetic aspects of the problem was expanded. The canonical bandwidth maximization problem is defined as the maximization of the time interval that the vehicles can use to drive through a sequence of signalized intersections without stopping; this is achieved solely by offset control. The extension of this framework aims at showing that the additional degree of freedom (i.e. variable speed limits) improves in every case the bandwidth. A further simulation campaign in a microscopic simulator shows the benefits of the theoretical bandwidth maximization on the standard traffic performance metrics. In particular, fluidity of traffic and lower number of stops result to be highly beneficial in terms of energy consumption, without losing much in terms of traveling time.

NON-A Project-Team

6. New Results

6.1. Highlights of the Year

- We are becoming world-recognized on homogeneous approach to estimation and control [13], [24].
- New method of stability analysis and control design for time-delay systems: Implicit Lyapunov-Krasovski Functionals [72].
- New dynamical model of population of oysters for water quality monitoring [44].
- New local path planning algorithm for mobile robots based on intermediate objectives [33].
- New patent on method and device for detecting a failure on an aircraft [85].
- New book on robust control design [82].

6.2. Homogeneity Theory And Analysis Of Nonlinear Systems

Homogeneity is a kind of symmetry, if it is presented in a system model, then it may simplify analysis of stability and performance properties of the system. The new results obtained in 2014 are as follows:

- The problem of scalability of trajectories in homogeneous and locally homogeneous systems is considered [46]. It is shown that the homogeneous systems have scalability property, and locally homogeneous systems possess this property approximately.
- Constructive conditions for verification of input-to-state stability property for discontinuous systems using geometric homogeneity have been proposed in [48]. The characterization of the asymptotic gain for such systems has been presented in [47].
- The problem of finite-time output stabilization of the double integrator is addressed in [14] applying the homogeneity approach. Robustness and effects of discretization on the obtained closed loop system are analyzed.
- The paper [24] extends notion of homogeneity to the time-delay nonlinear systems. Generalizations and specifications of the homogeneity approach to time-delay nonlinear systems are given in [57], where, for instance, the stability independently on delay has been analyzed.
- In [75] the uniform stability notion for a class of non-linear time-varying systems is studied using the homogeneity framework. The results are applied to the problem of adaptive estimation for a linear system.
- The Implicit Lyapunov Function (ILF) method has been applied for homogeneous differentiator design [70]. The procedure for adjustment of differentiator parameters has been resented in the form of semi-definite programming problem. ILF-based algorithms of robust finite-time and fixed-time stabilization of the chain of integrators were developed in [34]. In [69] they were adapted for the second order sliding mode control design.
- The tutorial on homogeneous methods in high sliding mode control has been published [13]. It stresses some recently obtained results of the team about homogeneity for differential inclusions and robustness with respect to perturbations in the context of input-to-state stability.

6.3. Model-Free Control

The model free control techniques form a new and quickly developing area of control theory. It has been established by the team members and nowadays these tools find many practical applications and attract a lot of attention due to their clear advantages for designers: they provide a control law independently in the model knowledge. The achievements obtained in 2014 are as follows:

- The paper [67] proposes a motion planning approach for non-holonomic mobile robots using i-PID controller. The effectiveness and the robustness of the proposed method are shown via several simulations.
- In [60] we show that the open-loop transfer functions and the stability margins may be defined within the recent model-free control setting. Several convincing computer experiments are presented including one which studies the robustness with respect to delays.

6.4. Algebraic Technique For Estimation, Differentiation And Its Applications

Elementary techniques from operational calculus, differential algebra, and non-commutative algebra lead to a new algebraic approach for estimation and detection. It is investigated in various areas of applied sciences and engineering. The following lists only some applications:

- The article [19] presents an algebraic on-line parameters estimation method for Linear Time Invariant (LTI) systems subject to polynomial perturbations. Particular attention is given to practical implementation.
- In the paper [43], we extend the modulating functions method to estimate the state and the unknown input of a linear time-varying system defined by a linear differential equation. Numerical results are given to show the accuracy and the robustness of the proposed estimators against corrupting noises.
- The paper [17] presents a new sensorless parameter identification method for permanent magnet stepper motors. The method exploits derived linear parameterizations and least-squares algorithms.
- In [36] a continuous-time least-squares parameter estimation method through evolution equations is proposed. A deterministic framework for the estimation under noisy measurements is proposed using a Sobolev space with negative index to model of the noise.
- Causation between time series is a most important topic in econometrics, financial engineering, biological and psychological sciences, and many other fields. A new setting is introduced in [42] for examining this rather abstract concept. The corresponding calculations, which are much easier than those required by the celebrated Granger-causality, do not necessitate any deterministic or probabilistic modeling.
- The paper [59] proposes a solution to the problem of velocity and position estimation for a class of oscillating systems whose position, velocity and acceleration are zero mean signals. The proposed scheme considers that the dynamic model of the system is unknown and only noisy acceleration measurements are available.
- The communications [63], [78] are devoted to solar irradiance and irradiation short-term forecasts, which are useful for electricity production. Several different time series approaches are employed.
- In [68] we present a simple algorithm to compute the factors of a Unimodular-Upper polynomial matrix decomposition. Such decomposition is useful for spatial multiplexing in multi-input multi-output(MIMO) channel transmission system since it enables to reduce the MIMO channel matrix into independent channels by a pre- and post-filtering.
- A fault-tolerant control method based on algebraic derivative estimation is introduced in [32]. It is applied on an electromagnetically supported plate as an example of a nonlinear and an open-loop unstable system.

6.5. Observability And Observer Design For Nonlinear Systems

Observability analysis and observer design are important issues in the field of control theory. Some recent results are listed below:

- The paper [12] deals with the observability analysis of linear time systems whose outputs are affected by unknown inputs. Three different definitions of observability are proposed. Sufficient conditions are deduced for each proposed definition.
- In [11] a method of the state estimation is proposed for a class of nonlinear systems with unknown inputs whose dynamics is governed by differential-algebraic equations (DAE). The estimation is done using a sliding mode high order differentiator.
- The recent algebraic parametric method proposed by Fliess and Sira-Ramirez has been extended to numerical differentiation problem in noisy environment [66]. The obtained algebraic differentiators are non-asymptotic and robust against corrupting noises.
- The paper [41] investigates the observer design problem of nonlinear impulsive systems with impact perturbation. By using the concept of normal form, it proposes a full order finite time observer, which guarantees the finite time convergence independent of the impact perturbation.
- The development of adaptive observer techniques for nonlinear systems in the output canonical form is proposed in [22] applying additional impulsive feedback in the observer equations. The stability is investigated.
- In [55] the problem of adaptive observer design in the presence of disturbances is studied, and an augmented adaptive observer is proposed using sliding mode methodology.

6.6. Sliding Mode Control And Estimation

Sliding mode algorithms are very popular for finite-time estimation and regulation. The recent results obtained by the group are as follows:

- In [71] the high-order sliding mode control design algorithm has been developed for MIMO system using ILF Method. Procedure for tuning of control parameters is presented using Linear Matrix Inequalities.
- A novel hybrid automaton admitting the modeling of both conventional and modern (high order) sliding mode systems is presented [65]. A scheme for defining hybrid-automaton executions beyond Zero points is proposed by means of introduction of Filippov-like executions.
- The paper [35] surveys mathematical tools required for stability/convergence analysis of modern sliding mode control systems and introduces the generalized Lyapunov theorems. Application of these results to finite-time stability analysis and settling time estimation of twisting second order sliding mode controller are given [73].
- The problem of the sliding mode control design is considered in [81] for the linear time-invariant disturbed system with the noised measurements of the output. The control law, which provides to the closed-loop system the optimal reaching (as close as possible) of the selected sliding surface, is designed using minimax state observer.
- The paper [50] deals with a signal-based method for robust and early detection of lock-in-place failures (a.k.a. jamming) in aircraft control surface servo-loops. The signal-based scheme is proposed using a sliding-mode differentiator. The developed monitoring scheme has been tested on Airbus test facilities located at Toulouse, France.
- In the paper [79], we investigate the problem of adaptive observer for simultaneous estimation of state and parameter for a class of nonlinear systems. Necessary condition for the existence of such an observer is derived. The paper [76] uses developed technique for states estimation and parameter identification for nonlinear Dengue epidemic model.
- The paper [80] investigates the problem of global finite-time observer design for a class of nonlinear systems which can be transformed into the output depending normal form.

6.7. Non-Linear, Sampled And Time-Delay Systems

Nonlinearities, sampling, quantization and time-delays cause serious obstructions for control and observer design in many fields of techniques and engineering (e.g. networked and internet systems, distributed systems etc.). The proposed by the team algebraic approach suits well for estimation and regulation in such a type of systems. The recent results are listed below:

- The method of Implicit Lyapunov-Krasovski Functional for stability analysis of time-delay systems is introduced in [72].
- The article [31] proposes a convex optimization approach for the design of relay feedback controllers. Furthermore, the approach is used in the sampled-data case in order to guarantee (locally) the practical stabilization to a bounded ellipsoid of the order of the sampling interval.
- The paper [40] addresses the controller design problem for bilateral teleoperation over unreliable networks. The stability and tracking performance analysis are presented for a novel force-reflecting emulator control scheme.
- The problem of time optimal control design is considered for a chain of integrators in [74]. The suboptimal continuous ILF-based solution is presented and compared with the optimal discontinuous feedback.
- In the erratum [26] recently proposed conditions on finite-time stability in time-delay systems are revisited and it is shown that they are incorrect. General comments on possibility of finite-time convergence in time-delay systems and a necessary condition are given.
- The problem of formulation of an equivalent characterization for instability is considered in [56]. The necessary part of the Chetaev's theorem on instability is formulated. Using the developed necessary instability conditions, the Anti-control Lyapunov Function (ALF) framework is extended and the Control Chetaev Function (CCF) concept is proposed as a counterpart of the Control Lyapunov function (CLF) theory.
- The paper [25] extends the notion of oscillations in the sense of Yakubovich to hybrid dynamics. Several sufficient stability and instability conditions for a forward invariant set are presented. The consideration is illustrated by analysis of a model of two-link compass-gait biped robot.
- The paper [15] deals with the design of an active fault-tolerant control strategy based on the supervisory control approach technique for linear time invariant MIMO systems affected by disturbances, measurement noise, and faults.
- The problem of phase regulation for a population of oscillating systems is considered in [21]. The proposed control strategy is based on a Phase Response Curve (PRC) model of an oscillator.
- The paper [51] deals with the design of an estimator-based supervisory Fault Tolerant Control scheme for Linear Time Invariant systems. A formal stability proof based on dwell-time conditions is established.
- In [39], we propose a general statistical framework for model based compressive sensing, where both sparsity and structure priors are considered simultaneously. It is based on the Latent Variable Analysis and the Gamma-Gaussian modelling.
- The paper [64] investigates the left invertibility for nonlinear time delay system with internal dynamics under some assumptions imposed on the internal dynamics. Causal and non causal estimation of the unknown inputs are respectively discussed, and the high-order sliding mode observer is used to estimate the observable states.
- In the paper [54] a simple second order model is proposed for modeling the pressure dynamics with a pure time delay on the control input. The Artstein transformation is applied in order to design the stabilizing robust nonlinear controller.

6.8. Set-Theoretic Methods of Control And Estimation

In many cases due to parametric and/or signal uncertainties presented in a plant model it is not possible to design a conventional observer, which provides a point-wise estimate of state in a finite time or asymptotically. In this case it is still frequently possible to design observers, which generate an estimate on the set of the admissible values of the state at the current instant of time. The recent new results in this field are listed below:

- An interval observer for Linear Time-Varying systems is proposed in [38]. A constructive approach to obtain a time-varying change of coordinates, ensuring the cooperativity of the observer error in the new coordinates, is provided in order to simplify the design of the interval observer.
- In [58] the problem of interval observer design is addressed for a class of descriptor linear systems with delays. An interval observation for any input in the system is provided. The control input is designed together with the observer gains in order to guarantee interval estimation and stabilization simultaneously.
- The estimation problem of a system with unknown time-delay and unknown input gains is considered in [49]. The interval observation technique is applied in order to obtain guaranteed interval of the system state.
- The book [82] introduces newly developed robust control design technique for a wide class of continuous-time dynamical systems called the “attractive ellipsoid method.” It studies nonlinear affine control systems in the presence of uncertainty and presents a constructive and easily implementable control strategy that guarantees certain stability properties.

6.9. Networked Robots

The mobile robots constitute an important area of practical development for the team:

- The paper [33] presents a path planning algorithm for autonomous navigation of non-holonomic mobile robots in complex environments. The irregular contour of obstacles is represented by segments. The optimal path planning problem is formulated as a constrained receding horizon planning problem and the trajectory is obtained by solving an optimal control problem with constraints.
- In [62] robot dynamic parameters are estimated based on power model associated with modulating functions, which avoids measuring or calculating the joint acceleration. At the same time, an advanced causal Jacobi derivative estimator is applied in order to get on-line robust derivatives from noisy measurements.
- The paper [61] provides a solution for the stabilization of a nonholonomic wheeled mobile robot which is affected by additive input disturbances. The solution is based on the supervisory control framework, finite-time stability and robust multi-output regulation.
- The demo video with the developments of NON-A team in networked robotics is given by https://www.youtube.com/watch?v=Mq_hB0UkzkY

6.10. Applications

As it was mentioned, Non-A is a kind of "method-driven" project, which deals with different aspects of finite-time estimation and control. Thus different applications are possible, ones touched this year are as follows (skipping the networked robots considered in the previous section):

- Method and device for detecting a failure on an aircraft are developed and patented [85].
- In [44] the measurements of valve activity in a population of bivalves under natural environmental conditions (16 oysters in the Bay of Arcachon, France) are used for a physiological model identification. A nonlinear auto-regressive exogenous (NARX) model is designed and tested. The developed dynamical model can be used for estimation of the normal physiological rhythms of permanently immersed oysters and, in particular, for ecological monitoring.

- The articles [53], [18], [20], [77] present novel control strategies for Permanent Magnet Synchronous Motor (PMSM), which does not ignore the relay nature of the actuators. A design procedure based on Linear Matrix Inequalities (LMI) allows us to derive the switching surfaces, which depend on the motor position. The sliding mode and nonlinear adaptive observers are designed for state estimation and parameters identification.
- The problem of air-fuel ratio stabilization in spark ignition engines is addressed in the paper [23]. The proposed strategy consists of proper switching among two control laws. The first one is based on an a priori off-line identified engine model and the second control law is adaptive. The supervisor realizes a switching rule between them providing better performance. Results of implementation on two vehicles are reported and discussed.
- The paper [37] deals with a control design for serial multicellular choppers. The novel scheme that uses two Petri nets (PNs) to carry out the control action is introduced. Experimental results from four and five-level choppers are used to emphasize the performance and the effectiveness of the proposed control scheme.
- The paper [52] is concerned with preliminary results on robot vibratory modes on-line identification using the external measurement provided by a laser tracker. A comparison between the algebraic method and the sliding modes for the parameter identification is proposed. Experimental identifications are proposed on a 6 degrees of freedom (DOF) manipulator robot Stäubli RX-170B.
- The papers [30], [29], [16] develop different fault detection schemes for robust and early detection of faults in aircraft control surfaces servo-loop. A complete Monte Carlo campaign from a high representative simulator, provided by Airbus as a part of the ADDSAFE project, as well as experimental results obtained on AIRBUS test facilities demonstrate the high fault detection performance, robustness and viability of the proposed techniques.
- The paper [28] deals with the problem of the practical tracking control of an experimental car-like system called the Robucar - a four-wheeled car in a single steering mode. A practical tracking controller is designed using the second-order sliding mode control. Experimental tests are presented and compared with the conventional sliding controller.
- Power converters are a very important for the control of high power systems. In the article [45] we propose a control strategy for minimizing the no-load conduction losses and analyze the transient behavior in case of load steps including output short-circuit.

QUANTIC Team

5. New Results

5.1. Highlights of the Year

- Experimental results in continuous measurement of error syndromes for a quantum error correction scheme developed by Mazyar Mirrahimi and his former PhD student Zaki Leghtas in close collaboration with the teams of Michel Devoret and Robert Schoelkopf (Department of Applied Physics of Yale University) have been published in Nature [13].
- Theoretical proposal on a new paradigm for universal quantum computation [12] has been chosen by the editors of the New Journal of Physics as an IOPselect paper for the novelty, significance and potential impact on future research.
- The EPOQ2 ANR Young Researcher project, led by Mazyar Mirrahimi, was highlighted in the 2013 annual report of Agence Nationale de la Recherche.

5.2. Dynamically protected cat-qubits: a new paradigm for universal quantum computation

Participant: Mazyar Mirrahimi.

In a close collaboration with the teams of Michel Devoret, Robert Schoelkopf and Liang Jiang (Department of Applied Physics, Yale university) and in particular a former member of our group, Zaki Leghtas, we have presented a new hardware-efficient paradigm for universal quantum computation. This paradigm is based on encoding, protecting and manipulating quantum information in a quantum harmonic oscillator. This proposal exploits multi-photon driven dissipative processes to encode quantum information in logical bases composed of Schrödinger cat states. More precisely, we consider two schemes. In a first scheme, a two-photon driven dissipative process is used to stabilize a logical qubit basis of two-component Schrödinger cat states. While such a scheme ensures a protection of the logical qubit against the photon dephasing errors, the prominent error channel of single-photon loss induces bit-flip type errors that cannot be corrected. Therefore, we have considered a second scheme based on a four-photon driven dissipative process which leads to the choice of four-component Schrödinger cat states as the logical qubit. Such a logical qubit can be protected against single-photon loss by continuous photon number parity measurements. Next, applying some specific Hamiltonians, we have provided a set of universal quantum gates on the encoded qubits of each of the two schemes. In particular, we have illustrated how these operations can be rendered fault-tolerant with respect to various decoherence channels of participating quantum systems. Finally, we have also proposed experimental schemes based on quantum superconducting circuits and inspired by methods used in Josephson parametric amplification, which should allow to achieve these driven dissipative processes along with the Hamiltonians ensuring the universal operations in an efficient manner.

This proposal was published in New Journal of Physics [12] and has also been chosen by the editor as an IOPselect paper for the novelty, significance and potential impact on future research.

5.3. Tracking photon jumps with repeated quantum non-demolition parity measurements

Participant: Mazyar Mirrahimi.

Quantum error correction (QEC) is required for a practical quantum computer because of the fragile nature of quantum information. In quantum error correction, information is redundantly stored in a large quantum state space and one or more observables must be monitored to reveal the occurrence of an error, without disturbing the information encoded in an unknown quantum state. Such observables, typically multi-quantum-bit parities, must correspond to a special symmetry property inherent in the encoding scheme. Measurements of these observables, or error syndromes, must also be performed in a quantum non-demolition way (projecting without further perturbing the state) and more quickly than errors occur. Previously, quantum non-demolition measurements of quantum jumps between states of well-defined energy have been performed in systems such as trapped ions, electrons, cavity quantum electrodynamics, nitrogen-vacancy centres and superconducting quantum bits. So far, however, no fast and repeated monitoring of an error syndrome had been achieved. Mazyar Mirrahimi has participated to an experiment performed by the group of Robert Schoelkopf (Department of Applied Physics, Yale University) where the quantum jumps of a possible error syndrome, namely the photon number parity of a microwave cavity, were tracked by mapping this property onto an ancilla quantum bit, whose only role is to facilitate quantum state manipulation and measurement. This quantity is just the error syndrome required in a QEC scheme proposed by Mazyar Mirrahimi and his former PhD student, Zaki Leghtas, and in a close collaboration with the teams of Michel Devoret and Robert Schoelkopf. This scheme should lead to a hardware-efficient protected quantum memory using Schrödinger cat states (quantum superpositions of different coherent states of light) in a harmonic oscillator [4]. We demonstrated the projective nature of this measurement onto a region of state space with well-defined parity by observing the collapse of a coherent state onto even or odd cat states. The measurement is fast compared with the cavity lifetime, has a high single-shot fidelity and has a 99.8 per cent probability per single measurement of leaving the parity unchanged. In combination with the deterministic encoding of quantum information in cat states realized earlier [10], the quantum non-demolition parity tracking that we have demonstrated represents an important step towards implementing an active system that extends the lifetime of a quantum bit. This result was published in Nature [9].

5.4. Dissipation-induced continuous quantum error correction for superconducting circuits

Participants: Joachim Cohen, Mazyar Mirrahimi.

Quantum error correction (QEC) is a crucial step towards long coherence times required for efficient quantum information processing (QIP). One major challenge in this direction concerns the fast real-time analysis of error syndrome measurements and the associated feedback control. Recent proposals on autonomous QEC (AQEC) have opened new perspectives to overcome this difficulty. As a sequel to our recent contributions to autonomous stabilization of maximally entangled states of superconducting qubits [53],[8], we have designed an AQEC scheme based on quantum reservoir engineering adapted to superconducting qubits. We have focused on a three-qubit bit-flip code, where three transmon qubits are dispersively coupled to a few low-Q resonator modes. By applying only continuous-wave drives of fixed but well-chosen frequencies and amplitudes, we engineer an effective interaction Hamiltonian to evacuate the entropy created by eventual bit-flip errors. We have provided a full analytical and numerical study of the protocol, while introducing the main limitations on the achievable error correction rates. This result was published in Physical Review A [11].

5.5. Continuous generation and stabilization of mesoscopic field superposition states in a quantum circuit

Participants: Ananda Roy, Mazyar Mirrahimi.

While dissipation is widely considered as being harmful for quantum coherence, it can, when properly engineered, lead to the stabilization of non-trivial pure quantum states. In a close collaboration with the teams of Michel Devoret and Douglas Stone (Department of Applied Physics, Yale University), and in the framework of a 6 months visit by Ananda Roy (PhD student at Yale), we proposed a scheme for continuous generation and stabilization of Schrödinger cat states in a cavity using dissipation engineering [15]. The scheme consists in first generating non-classical photon states with definite parity by means of a two-photon

drive and dissipation, and then stabilizing these transient states against single-photon decay. The single-photon stabilization is autonomous, and is implemented through a second engineered bath, which exploits the photon number dependent frequency-splitting due to Kerr interactions in the strongly dispersive regime of circuit QED. Starting with the Hamiltonian of the baths plus cavity, we derived an effective model of only the cavity photon states along with analytic expressions for relevant physical quantities, such as the stabilization rate. The deterministic generation of such cat states is one of the key ingredients in performing universal quantum computation.

5.6. Extending robustness and randomization from consensus to symmetrization algorithms

Participant: Alain Sarlette.

In the framework of a collaboration with Francesco Ticozzi (University of Padova) on common points between quantum and classical network dynamics, we developed a general "symmetrization" framework which covers robust ways to generate dynamics in several algorithmic and control contexts [18]. The starting point was the question of generalizing so-called "consensus" algorithms to networks composed of quantum units. In order to define state information exchange without requiring state communication (an impossible feat given the quantum no-cloning theorem), an operational viewpoint on consensus had been proposed by Alain Sarlette and co-authors in the previous year. In this new result, the scope of this operational viewpoint is considerably extended by considering it as a "symmetrization" procedure with respect to some discrete group, completely abstracting away the actual action space. It is shown that this abstraction covers existing procedures ranging from network synchronization to random state generation (not in networks) and averaging-based open-loop control procedures. The interest of viewing those procedures under the common "symmetrization" framework proposed is twofold: convergence proofs follow from a general result that we have established; and robustness to randomized actions and (specific) parameter uncertainties is shown to carry over from the "consensus" literature. It is further anticipated that the approach might be a guideline for new algorithmic designs in the future.

5.7. Accelerating consensus by spectral clustering and polynomial filters

Participant: Alain Sarlette.

The previous work of Alain Sarlette about quantum consensus and symmetrization has been further explored towards quantum-induced accelerations of algorithms, thermalization processes and random walks. This work is still at a preliminary stage. It has been noticed that some non-quantum acceleration possibilities were not fully explored and this has led to two publications that establish preliminary clarifications for our main goal. In [17], a standing conjecture has been proved which claims that if only the spectral gap of a graph is known (i.e. a bound on its lowest and largest eigenvalues), then by adding m local memories to each node no faster convergence can be obtained than by adding $m = 2$ local memories. The conjecture is proved with an analogy to root locus techniques, and a network-centric (e.g. information-theory-based) argument for this fact is currently missing, but at least the fact has been established. This allows for direct comparisons with "quantum random walk" accelerations, which obtain the same speed as $m = 2$ but with a different tweak, that is based among others on more knowledge of the network structure. In this spirit, we have clarified in [16] how classical consensus with time-varying filters can benefit from knowledge of extra bounds on the graph eigenvalue locations (without knowing them exactly, which is the case considered in the existing literature). This work also observes how the speed-up trades off with robustness to network modifications.

5.8. Integral control on Lie groups

Participant: Alain Sarlette.

A big challenge for the long-term control of interacting networks is their robustness to systematic biases. Integral control is a standard way to counter them when a target output can be measured. This method has been originally proposed, and extensively studied, for linear systems. However when the system (output) evolves on a nonlinear state space, the standard "integration" technique cannot be straightforwardly applied. Especially for global motions on spaces like the circle, sphere or (real or complex) rotation groups, the output integration viewpoint becomes problematic. We have hence proposed a new viewpoint on integral control, based on integrating the intended input [19]. For linear state spaces, it is equivalent to the standard definition. For nonlinear state spaces, this viewpoint can be transposed verbatim modulo introduction of a transport map on the tangent bundle, which is almost always present for control design purposes. In particular for systems on Lie groups, which are ubiquitous in robotics and in quantum physics, a full analysis of fully actuated systems has been proposed. The more challenging extension to underactuated systems is underway.

CLASSIC Project-Team

4. New Results

4.1. Corpus linguistics and Markov substitute processes

Thomas Mainguy and Olivier Catoni studied a new statistical model for natural language modeling, called Markov substitute processes. This model is based on a set of conditional independence properties that are more general than the Markov field assumption. It has connections with context free grammars and forms a collection of exponential families having for this reason nice estimation properties.

4.2. Kernel Principal Component Analysis and spectral clustering

Ilaria Giulini and Olivier Catoni continued their study of dimension free bounds for the estimation of the Gram matrix and more generally for the estimation of the expectation of a random symmetric matrix from an i.i.d. sample. This study, using PAC-Bayes bounds, both leads to new robust estimators with applications to Principal Component Analysis in high of even infinite dimension, and new bounds for the usual empirical Gram matrix estimate. Getting dimension free bounds is important to get new results on Kernel PCA. Applications were also studied to density estimation and to spectral clustering.

DOLPHIN Project-Team

6. New Results

6.1. Highlights of the Year

In [23], we have revisited the design and implementation of the Branch and Bound algorithm for solving on large scale distributed environments challenging permutation-based optimization problems such as Q3AP. The new approach includes original ways to efficiently deal with some crucial issues mainly, dynamic adaptive load balancing and fault tolerance. The approach allowed to solve to optimality for the first time a difficult Q3AP instance (Nug15) on the nation-wide Grid'5000 computational grid. The resolution was completed within less than 12 days using an average of 1,123 processing cores distributed over 6 Grid'5000 sites and peaked at 3,427.

6.2. Fitness Landscape Analysis for Multiobjective Optimization

Participant: Arnaud Liefvooghe.

The properties of local optimal solutions in multi-objective combinatorial optimization problems are crucial for the effectiveness of local search algorithms, particularly when these algorithms are based on Pareto dominance. Such local search algorithms typically return a set of mutually non-dominated Pareto local optimal (PLO) solutions, that is, a PLO-set. In [34], we investigate two aspects of PLO-sets by means of experiments with Pareto local search (PLS). First, we examine the impact of several problem characteristics on the properties of PLO-sets for multi-objective NK-landscapes with correlated objectives. In particular, we report that either increasing the number of objectives or decreasing the correlation between objectives leads to an exponential increment on the size of PLO-sets, whereas the variable correlation has only a minor effect. Second, we study the running time and the quality reached when using bounding archiving methods to limit the size of the archive handled by PLS, and thus, the maximum size of the PLO-set found. We argue that there is a clear relationship between the running time of PLS and the difficulty of a problem instance.

Complementarily, in [25] we study the behavior of three elitist multi- and many-objective evolutionary algorithms in generating a high-resolution approximation of the Pareto set. Several search-assessment indicators are defined to trace the dynamics of survival selection and measure the ability to simultaneously keep optimal solutions and discover new ones under different population sizes, set as a fraction of the Pareto set size. Our study clarifies the ability and efficiency of the algorithms assuming scenarios where it is relatively easy to hit the Pareto set, showing the importance to properly assess algorithm's performance according to the task of the optimizer in many-objective optimization.

6.3. Combining dynamic programming and metaheuristics for the Unit Commitment Problem

Participants: Sophie Jacquin, Laetitia Jourdan, El-Ghazali Talbi.

DYNAMOP (DYNAMIC programming using Metaheuristic for Optimization Problems) is a new dynamic programming based on genetic algorithm. It uses a representation based on a path in the graph of states of dynamic programming which is adapted to dynamic structure of the problem and facilitates the hybridization between evolutionary algorithms and dynamic programming. Experiments indicate that the proposed approach outperforms the best known in literature [44].

6.4. Multi-decoding strategy for Multi-objective Unit Commitment Problem

Participants: Sophie Jacquin, Lucien Mousin, Igor Machado, Laetitia Jourdan, El-Ghazali Talbi.

In the multiobjective version of the UCP taking the emission of gas into account, the dispatching problem remains easy to solve whereas considering it separately remains interesting. A multi-objective GA handling binary vectors is applied. However for a binary representation there is a set of solutions of the dispatching problem that are pareto equivalent. In this approach a genotypic solution is associated with a set of phenotypic solutions. This set of solutions is from the optimal pareto front solution of the dispatching problem associated with the genotypic solution. As many phenotypic solutions are attached to a single genotypic solution, the fitness assignment and diversity assignment methods of NSGA-II have to be adapted. The multi decoding embedded approach has shown very good performances in comparison to two other less complex decoding systems.

6.5. Decomposition-Based Algorithms for Multiobjective Optimization

Participants: Dimo Brockhoff, Bilel Derbel, Arnaud Liefooghe, Gauvain Marquet, El-Ghazali Talbi.

Recently, there has been a renewed interest in decomposition-based approaches for evolutionary multiobjective optimization. Those algorithms decompose a multiobjective optimization problem into several single-objective optimization problems by using so-called scalarizing functions which are then simultaneously optimized by single-objective algorithms in a cooperative manner.

Our contributions to decomposition-based algorithms in 2014 has been three-fold. Firstly, we investigated in [28] the general impact of different scalarizing functions and their parameters on the search performance. We thereby abstracted from any specific algorithm and only considered the difficulty of the single scalarized problems in terms of the search ability of a $(1+\lambda)$ -EA on bi-objective NK-landscapes. Secondly, in [16], we proposed a new distributed heuristic for approximating the Pareto set of bi-objective optimization problems. Given a number of computing nodes, we self-coordinate them locally, in order to cooperatively search different regions of the Pareto front. As local information, every node uses only the positions of its neighbors in the objective space and evolves its local solution adaptively, based on what we term a ‘localized fitness function’. We deployed our distributed algorithm using a computer cluster of hundreds of cores. At last, we enhanced the algorithm MOEA/D, a prominent example of a decomposition-based algorithm from the literature, by investigating the idea of evolving the whole population simultaneously at once. We thereby proposed new alternative selection and replacement strategies that can be combined in different ways within a generic and problem-independent framework [36].

6.6. Link-Heterogeneous work stealing for Branch-and-Bound Algorithms

Participants: T-T Vu, Bilel Derbel.

In this work [41], we push forward the design of parallel and distributed optimization algorithms running on link-heterogeneous systems where network latencies can deeply impact performance. We consider parallel Branch-and-Bound (B&B), viewed as a generic algorithm searching in a dynamic tree representing a set of candidate solutions built dynamically. A major challenge is then to deal with the irregularity of B&B computations and to distribute workload evenly at runtime. In this context, the random work-stealing paradigm has been proved to be extremely beneficial. However, it is known to perform loosely in non-homogeneous distributed systems where communications costs are a major obstacle for high performance. We there-by investigate the design of an effective work-stealing protocol dealing with the heterogeneity of network link latencies. We propose a generic distributed algorithm which can be easily implemented to fit different types of heterogeneity. The proposed algorithm extends on reference approaches, namely Probabilistic Work Stealing (PWS), and Adaptive Cluster-aware Random Stealing (ACRS); by introducing new adaptive control operations that are shown to be highly accurate in increasing work locality and decreasing steals cost. Through emulations on top of a real test-bed, we provide a comprehensive experimental analysis including: (i) a comparative study on a broad range of harsh network scenarios going from flat networks to more hierarchical grid-like networks, and (ii) an in-depth analysis of protocols’ behavior at the aim of gaining new insights into dynamic load-balancing in heterogeneous distributed environments. Over all experimented configurations, our results show that although the proposed protocol is not tailored for a specific networked platform, it can save 30% execution time in average compared to its competitors, while demonstrating high quality self-adjusting capabilities.

6.7. New data structure for solving large permutation problems using multi-core B&B

Participants: Rudi Leroy, Nouredine Melab.

Solving large permutation problems using parallel B&B algorithms results in the generation of a very large pool of subproblems. Defining an efficient data structure is highly required to store and manage efficiently that pool. In [31], we have proposed a new dedicated data structure called *Integer-Vector-Matrix* (or *IVM* and redefined the operators of the B&B algorithm acting on it. We have also revisited the Work Stealing mechanism on multi-core processors. In the proposed approach, work units are coded in a coalesced way using factoradic-based intervals, and private IVMs are used to store and explore locally subsets of subproblems. The IVM-based approach has been experimented and compared to the approach based on concurrent linked-list, which is often used. The results show that our approach is more efficient in terms of memory usage and management time. In [31], we have investigated various work stealing strategies based on different victim selection and granularity policies. This later paper has been selected for a special issue in the CCPE international journal.

6.8. B&BGrid revisited for solving challenging Q3AP instances on large volatile computational environments

Participants: Nouredine Melab, El-Ghazali Talbi.

We have revisited the design and implementation of parallel B&B algorithms on multi-core (collaboration with UMONS, Belgium) and grid-wide environments (collaboration with University of Luxembourg and UMONS, Belgium)) for solving to optimality and efficiently large permutation problem instances. We have proposed a gridification approach of the B&B algorithm called B&B@Grid. This later includes a dynamic load balancing technique and a checkpointing mechanism for permutation problems. The approach has been validated through single-permutation Flowshop problem. In [23], we have extended the approach to deal with more than one permutation. To do that, we have revisited the design and implementation of the dynamic load balancing and checkpointing mechanisms for multiple permutation-problems. The new approach allowed the optimal resolution on a nation-wide grid (Grid'5000) of a difficult instance of the 3D quadratic assignment problem (Q3AP). To solve the instance, an average of 1,123 processing cores were used during less than 12 days with a peak of around 3,427 CPU cores.

GEOSTAT Project-Team

6. New Results

6.1. Highlights of the Year

Paper **Spanning the Scales of Granular Materials through Microscopic Force Imaging** by N. Brodu *et al.* accepted in **Nature Communications** (will appear in 2015).

BEST PAPER AWARD :

[36] **IEEE TENSYPMP 2014**. B. XU, S. BINZAK, S. JACQUIR, O. PONT, H. YAHIA.

6.2. Super-resolution for Earth Observation data

Participants: Hussein Yahia, Joël Sudre, Oriol Pont, Véronique Garçon, Dharmendra Singh.

References: [17], [30], [28], [38], [29].

With partners at LEGOS and in the framework of the OPTIC associated team (7.4.1), we are developing the novel super-resolution approaches for Universe Sciences data. New results are obtained for ocean dynamics, partial pressures pCO_2 between the ocean and the atmosphere, and data fusion.

6.3. Fast and Accurate Texture Recognition with Multilayer Convolution and Multifractal Analysis

Participants: Hicham Badri, Hussein Yahia, Khalid Daoudi.

Reference: [25].

A fast and accurate texture recognition system is presented. It consists in extracting locally and globally invariant representations of a given texture image. The mapping from the locally to the globally invariant representation is based on a scale-invariant method via the calculation of singularity exponents. The final descriptor is extracted from the distribution of these exponents and leads to a more accurate descriptor compared to the popular box-counting method. We also propose to use a combination of the generative PCA classifier together with multi-class SVM as well as a synthetic training strategy. Experiments show that the proposed solution outperforms existing methods on three challenging public benchmark datasets, while being computationally efficient.

6.4. Fast Image Edge-Aware Processing

Participants: Hicham Badri, Hussein Yahia, Driss Aboutajdine.

Reference: Article *Fast Edge-Aware Processing via First Order Proximal Approximation* by H. Badri, H. Yahia, D. Aboutajdine, accepted with minor revision in **IEEE Transactions on Visualization & Computer Graphics**, will be in HAL in 2015.

We present a framework for fast edge-aware processing of images and videos. This is an extension of our previous SIGGRAPH Asia 2013 paper. The proposed approach uses non-convex sparsity on the gradients of the latent smooth image to better preserve sharp edges. We develop tools based on first order proximal estimation for fast processing. We also propose fast and efficient numerical solutions based on separable filters estimation, which enables our method to perform fast high-quality smoothing on large-scale images. Extensive experiments show that the proposed method produces high-quality smoothing compared to state-of-the-art methods, while being fast and simple to implement.

6.5. Cardiac arrhythmia induced by mild hypothermia in vitro – a pitchfork bifurcation type process

Participants: Binbin Xu, Oriol Pont.

Reference: [20].

The neurological damage after cardiac arrest constitutes a big challenge of hospital discharge. The mild therapeutic hypothermia (MTH) (34°C - 32°C) has shown its benefit to reduce this type of damage. However, it can have many adverse effects, among which the cardiac-arrhythmia-generation-a-posteriori (CAGP) can represent up to 34%. Our study with a cardiac culture in vitro showed that at 35°C the CAGP can be induced. The process of MTH can be represented by a Pitchfork bifurcation, which could explain the different ratio of arrhythmia among the adverse effects after this therapy. This nonlinear dynamics suggests that a variable speed of cooling / rewarming, especially when passing 35°C , would help to decrease the ratio of post-hypothermia arrhythmia and then improve the hospital output.

6.6. Characterizing the dynamics of cardiac arrhythmia

The dynamics of cardiac arrhythmia is quite complex. Better understanding its mechanism can help to improve the treatment. In vitro cultures of cardiac cells which has similar parameters as cell of human's heart represent valuable tool and model to study this issue.

6.6.1. by Complexity Analysis

Participants: Binbin Xu, Oriol Pont.

References: [36], [39].

Stochastic approaches provide a type of methods to characterize cardiac arrhythmia, aimed at quantifying the statistical properties of the time series. Complexity analysis such as Approximate Entropy (ApEn) and Sample Entropy (SampEn), are particularly useful to analyze time series in electro-cardiology in which the signals are characterized by their high regularity in normal condition in contrast to irregularity in pathological cases. It is shown that ApEn and SampEn can not only serve as a discrimination index, but also provide another parameter which showed doubling phenomenon. It proves in other terms that bifurcation happens in case arrhythmia. See figure 1 .

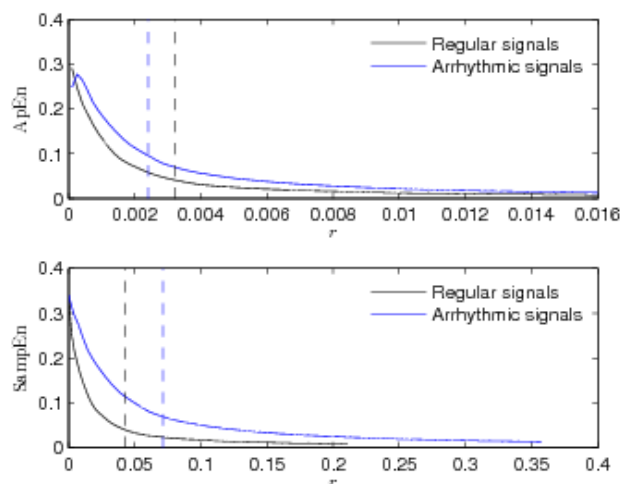

Figure 1. Illustration of ApEn / SampEn analysis for normal and arrhythmic electrical field potential.

6.6.2. by Phase Space Reconstruction

Participants: Oriol Pont, Binbin Xu.

References: [19], [40], [22].

Phase space reconstructions of electrical field potential signals in normal and arrhythmic cases are performed by characterizing the nonlinearity of these signals. The phase space reconstructions highlight attractors, whose dimension reveals that they are strange, depicting a deterministic dynamics of chaotic nature in the in vitro model. The electrical activity of the heart consists of nonlinear interactions emerging as a complex system. Electrocardiographic imaging provides a full spatiotemporal picture of the electric potential on the human epicardium. Rhythm reflects the connection topology of the pacemaker cells driving it. Hence, characterizing the attractors as nonlinear, effective dynamics can capture the key parameters without imposing any particular microscopic model on the empirical signals. A dynamic phase-space reconstruction from an appropriate embedding can be made robust and numerically stable with the methods developed in the team. With these, we have been able to show how both the phase-space descriptors and those of the a priori unrelated singularity analysis are able to highlight the arrhythmogenic areas on cases of atrial fibrillation. See figure 2 .



Figure 2. Illustration of phase space analysis of normal and arrhythmic electrical field potential.

6.7. The origin of the myth FitzHugh-Nagumo model

Participants: Binbin Xu, Oriol Pont.

Reference: [37].

History became legend. Legend became myth. Derived from the pioneer ionic Hodgkin-Huxley model and due to its simplicity and richness from a point view of nonlinear dynamics, the FitzHugh-Nagumo model (FHN) is one of the most successful simplified neuron / cardiac cell model. 60 years later, there exist many variations of this model whose parameters (ε , γ and α) are often used in biased conditions. The related results would be questionable. This study showed that α controls the global dynamics of FHN. $\alpha > 0$, the cell is in refractory mode and does not respond to external stimulation; if $\alpha < 0$, the cell is excitable. ε controls the main morphology of the action potential generated. γ influences barely AP, it showed linear relationship with the period and duration of AP. Though it can be freely chosen for excitable cell, but smaller values are recommended.

6.8. Pathological Speech Analysis

Participants: Khalid Daoudi, Vahid Khanagha, Blaise Bertrac, Safa Mrad, Ashwini Jaya Kumar.

References: [14], [13], [26], [27].

We applied our recent results in nonlinear speech analysis to the field of pathological speech detection and classification. We presented new insights in the task of normal-vs-pathological voice classification using the widely used Kayeometrics database. In particular, we showed that hat one single parameter, derived from matching pursuit decomposition of speech, allow perfect discrimination between normal and dysphonic voices of these database. This result raises some important questions on the way this task is generally addressed. Using our GCI detection algorithm, we also proposed new definitions of standard voice perturbation measures (jitter, shimmer...) which lead to significantly higher classification accuracy. Our new measures have the strong advantage to avoid the usual periodicity and linearity assumptions. On the other hand, we started investigating the task of discrimination between Parkinson's and healthy voices. Our phonetic segmentation algorithm has potentially the ability to detect vowel onset and offset regions which have different structures in Parkinson's voices that in healthy ones. This preliminary result is promising and we are continuing research in this direction.

6.9. Statistics and detection of most unpredictable points in data sets

Participants: Nicolas Brodu, Hussein Yahia, Suman-Kumar Maji.

References: [21], [16].

The assumption that local regularity amounts to predictability can be challenged, depending on the model that one may use to make predictions. A statistical framework, "computational mechanics", has been explicitly designed over the past 30 years, that precisely formalizes notions of causality and predictability within discrete data sets. Patterns with similar causal influence on the data are clustered in equivalence classes. Taken together, these classes form a Markovian automaton by definition, since no extra information is needed from other classes to (statistically) predict the influence of a group of patterns on the rest of the data set. These automata are defined at the lowest data description scale, but it has been suggested that sub-automata (thus clusters at larger scales) form an ideal coarse-graining of the system in terms of predictability (thus also descriptive power). The theory is also deeply rooted in statistical physics, offering a unique perspective on how macroscopic variables could be derived from a microscopic description of a studied system. Preliminary results are promising and show that, for example, edges may be detected in images with a precursor continuous implementation of the theory extension under construction. In order to make more progress, advanced statistical and computational developments are necessary to carry this work. In order to facilitate this development, N. Brodu has submitted a Marie-Curie outgoing fellowship that, if accepted, would allow to partner with Australian leaders on statistics and data processing (University of Melbourne, department of Mathematics).

6.10. Image Reconstruction from Highly Corrupted Gradients

Participants: Hicham Badri, Hussein Yahia, Driss Aboutajdine.

Reference: [23].

Surface-from-Gradients (SfG) is an important step in many imaging applications. It consists in reconstructing an image/surface from corrupted gradient fields, which results in an ill-posed problem. We propose to use sparsity to regularize the problem. We use sparsity in the gradient field together with a robust norm on the data-fitting term (CVPR 2014). In a work in progress, we make use of a non-local regularization that manipulates non-local similar patches of the corrupted gradient and forcing them to be low-rank. The two approaches significantly outperform previous optimization-based SfG methods on both synthetic and real data.

6.11. Local/Non-Local Noisy Image Deconvolution

Participants: Hicham Badri, Hussein Yahia.

Reference: [24].

Image deconvolution is a standard step in many imaging applications. Sparse local regularization has shown to be fast but tends to over-smoothing images. On the other hand, non-local priors that manipulate similar patches produce better results but tend to be much slower. In this paper, we combine both local and non-local methods in one framework to offer both good quality image reconstruction and computational efficiency in the presence of noise. By studying the non-local singular values of the image patches, we show that the non-local patches tend to be much similar in the blurred version of the image. We thus use low-rank estimation to first estimate a blurred but noise-free image. Secondly, we show that this denoising step introduces outliers in the deconvolution model and propose an efficient optimization method to tackle this problem. Experiments show that the proposed method produces comparable results to non-local methods while being more computationally efficient.

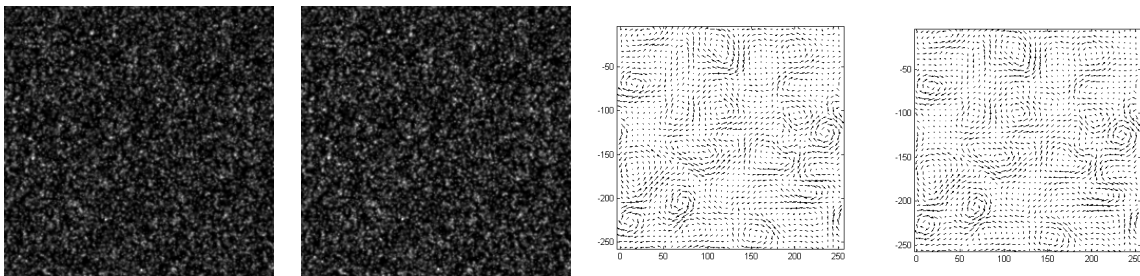

Figure 3. Motion estimation using the proposed method. From left to right: image sequences (2 images, at t and $t + 1$ respectively) the ground-truth and the estimated flow (errors, from left to right : $MSE=0.063$, $AAE=3.562$, $EPE=0.100$).

6.12. Detection and dynamics of coastal upwelling

Participants: Ayoub Tamim, Khalid Daoudi, Hussein Yahia, Joël Sudre, Driss Aboutajdine.

References: [18], [34], [35], [33].

An unsupervised classification method is developed for the coarse segmentation of Moroccan coastal upwelling using the Sea Surface Temperature (SST) satellite images. The algorithm is used to provide a seasonal variability of upwelling activity in the southern Moroccan Atlantic coast using 70 Sea Surface Temperature (SST) images of the years 2007 and 2008. The performance of the proposed methodology has been validated by an oceanographer, showing its effectiveness for automatic delimitation of Moroccan upwelling region. We have also explored the applicability of the Fuzzy c-means (FCM) clustering, using an adaptive cluster merging, for the problem of detecting the Moroccan coastal upwelling areas in SST satellite images.

6.13. Nonlinear signal processing for adaptive optics

Participants: Suman-Kumar Maji, Hussein Yahia, Thierry Fusco.

Reference: [31].

The work developed by PhD student Suman Kumar Maji on nonlinear approaches to phase reconstruction in adaptive optics has been presented at the SPIE Astronomical Telescopes + Instrumentation, one of the great events in the field.

6.14. Turbulent Flow Estimation

Participants: Hicham Badri, Hussein Yahia.

We use singularity exponents (SE) to regularize the problem of turbulent flow estimation under the assumption that the brightness constancy constraint holds also for (SE). We also use weighted filtering (Lucas–Kanade’s solution) and sparsity on the data-fitting term to improve robustness to outliers. The proposed motion estimation is built on a Gaussian pyramid and uses the theory of warping for a better estimation of large displacements. Experiments on synthetic data show that the proposed method outperforms sophisticated methods while being simple. See figure 3 .

6.15. Adaptive Transfer Real Image Restoration

Participants: Hicham Badri, Hussein Yahia.

Image restoration is a very challenging task in low-level vision and is extensively used in many imaging applications. Sparsity in various forms (dictionary learning, low-rank estimation,...) has shown to be the key for successful image denoising. However, the standard noise model used to validate the results is mainly Gaussian and uniform, with known standard deviation. Unfortunately, these assumptions do not hold for real camera noise. Instead of using sparsity to model the singular values of non-local clean similar patches, we use a learning model that trains a mapping between the noisy and ground-truth clean singular values. The training is performed on real camera noise, contrary to previous methods. Experiments show that the proposed method significantly outperforms previous denoising works on real non-uniform noise and does not require estimating the standard deviation of the corruption. See figure 4 .



Figure 4. Image restoration demonstration on a severely corrupted image. The proposed method leads to a much better restoration quality compared to the standard BM3D method. From left to right: Ground-Truth, Noisy image, BM3D (20.46 dB), Proposed (22.25 dB).

6.16. Augmented Lagrangian for Fast Multi-Sparse Optimization

Participants: Hicham Badri, Hussein Yahia, Khalid Daoudi.

Sparsity has become one of the most important notions in many imaging applications. We address in this paper the problem of multi-sparse optimization, when the energy to minimize contains multiple sparse terms instead of a single one. We show that applying off-the-shelf proximal-based solvers such as ADMM results in a high computational cost due to the complexity of the resulting sub-problems in the case of multi-sparsity. We propose an efficient extension of ADMM for multi-sparse optimization, we study its convergence and complexity and show how it can be applied to computer vision problems. Experiments show that the proposed solver is not only computationally efficient, but also leads quickly to higher-quality results compared to the popular half-quadratic solver.

6.17. On the Fly Hybrid Video Denoising

Participants: Hicham Badri, Hussein Yahia.

Video denoising is a standard pre-processing step in many imaging applications. Non-local methods such as the BM3D method adapted to videos have shown to produce good quality results, but these methods require multiple frames to produce a temporally coherent result, especially when the amount of noise is high. On the other hand, using a hybrid camera, we can get clean images of the scene. However, these images suffer from low-temporal coherence. We present a new approach to video denoising which consists in learning a mapping between the clean images and their corresponding noisy frames and propagate denoising to intermediate frames. To improve temporal coherency, we use a fast method method to sparsify the temporal gradient. Experiments on high-resolution videos show that the proposed method produces good quality on the fly video denoising while being computationally efficient.

MISTIS Project-Team

6. New Results

6.1. Highlights of the Year

6.1.1. *P-Locus software and Pixyl start-up project*

The work on the P-Locus software has been exploited in order to create a start-up in January 2015. The project called Pixyl have been accepted by the GATE1 incubator and has been awarded a BPI emergence prize. It is led by Senan Doyle (future CEO). The other co-founders are Michel Dojat (INSERM, GIN), Florence Forbes (Inria, Mistis) and IT-Translation.

6.2. Mixture models

6.2.1. *Parameter estimation in the heterogeneity linear mixed model*

Participant: Marie-José Martinez.

Joint work with: Emma Holian (National University of Ireland, Galway)

In studies where subjects contribute more than one observation, such as in longitudinal studies, linear mixed models have become one of the most used techniques to take into account the correlation between these observations. By introducing random effects, mixed models allow the within-subject correlation and the variability of the response among the different subjects to be taken into account. However, such models are based on a normality assumption for the random effects and reflect the prior belief of homogeneity among all the subjects. To relax this strong assumption, Verbeke and Lesaffre (1996) proposed the extension of the classical linear mixed model by allowing the random effects to be sampled from a finite mixture of normal distributions with common covariance matrix. This extension naturally arises from the prior belief of the presence of unobserved heterogeneity in the random effects population. The model is therefore called the heterogeneity linear mixed model. Note that this model does not only extend the assumption about the random effects distribution, indeed, each component of the mixture can be considered as a cluster containing a proportion of the total population. Thus, this model is also suitable for classification purposes.

Concerning parameter estimation in the heterogeneity model, the use of the EM-algorithm, which takes into account the incomplete structure of the data, has been considered in the literature. Unfortunately, the M-step in the estimation process is not available in analytic form and a numerical maximisation procedure such as Newton-Raphson is needed. Because deriving such a procedure is a non-trivial task, Komarek et al. (2002) proposed an approximate optimization. But this procedure proved to be very slow and limited to small samples due to requiring manipulation of very large matrices and prohibitive computation.

To overcome this problem, we have proposed in an alternative approach which consists of fitting directly an equivalent mixture of linear mixed models. Contrary to the heterogeneity model, the M-step of the EM-algorithm is tractable analytically in this case. Then, from the obtained parameter estimates, we can easily obtain the parameter estimates in the heterogeneity model.

6.2.2. *Taking into account the curse of dimensionality*

Participants: Stéphane Girard, Alessandro Chiancone, Seydou-Nourou Sylla.

Joint work with: C. Bouveyron (Univ. Paris 5), M. Fauvel (ENSAT Toulouse) and J. Chanussot (Gipsa-lab and Grenoble-INP)

In the PhD work of Charles Bouveyron (co-advised by Cordelia Schmid from the Inria LEAR team) [67], we propose new Gaussian models of high dimensional data for classification purposes. We assume that the data live in several groups located in subspaces of lower dimensions. Two different strategies arise:

- the introduction in the model of a dimension reduction constraint for each group
- the use of parsimonious models obtained by imposing to different groups to share the same values of some parameters

This modelling yields a new supervised classification method called High Dimensional Discriminant Analysis (HDDA) [4]. Some versions of this method have been tested on the supervised classification of objects in images. This approach has been adapted to the unsupervised classification framework, and the related method is named High Dimensional Data Clustering (HDDC) [3]. Our recent work consists in adding a kernel in the previous methods to deal with nonlinear data classification and heterogeneous data [12]. We also investigate the use of kernels derived from similarity measures on binary data. The targeted application is the analysis of verbal autopsy data (PhD thesis of N. Sylla): Indeed, health monitoring and evaluation make more and more use of data on causes of death from verbal autopsies in countries which do not keep records of civil status or with incomplete records. The application of verbal autopsy method allows to discover probable cause of death. Verbal autopsy has become the main source of information on causes of death in these populations.

6.2.3. *Location and scale mixtures of Gaussians with flexible tail behaviour: properties, inference and application to multivariate clustering*

Participant: Florence Forbes.

Joint work with: Darren Wraith from QUT, Brisbane Australia.

Clustering concerns the assignment of each of N , possibly multidimensional, observations y_1, \dots, y_N to one of K groups. A popular way to approach this task is via a parametric finite mixture model. While the vast majority of the work on such mixtures has been based on Gaussian mixture models in many applications the tails of normal distributions are shorter than appropriate or parameter estimations are affected by atypical observations (outliers). The family of location and scale mixtures of Gaussians has the ability to generate a number of flexible distributional forms. It nests as particular cases several important asymmetric distributions like the Generalised Hyperbolic (GH) distribution. The Generalised Hyperbolic distribution in turn nests many other well known distributions such as the Normal Inverse Gaussian (NIG) whose practical relevance has been widely documented in the literature. In a multivariate setting, we propose to extend the standard location and scale mixture concept into a so called multiple scaled framework which has the advantage of allowing different tail and skewness behaviours in each dimension of the variable space with arbitrary correlation between dimensions. The approach builds upon, and develops further, previous work on scale mixtures of Gaussians [21]. Estimation of the parameters is provided via an EM algorithm with a particular focus on NIG distributions. Inference is then extended to cover the case of mixtures of such multiple scaled distributions for application to clustering. Assessments on simulated and real data confirm the gain in degrees of freedom and flexibility in modelling data of varying tail behaviour and directional shape. In addition, comparison with other similar models of GH distributions shows that the later are not as flexible as claimed.

6.2.4. *Bayesian mixtures of multiple scaled distributions*

Participants: Florence Forbes, Alexis Arnaud.

Joint work with: Emmanuel Barbier and Benjamin Lemasson from Grenoble Institute of Neuroscience.

In previous work [21], inference for mixtures of multiple scaled distributions has been carried out based on maximum likelihood principle and using the EM algorithm. In this work we consider a Bayesian treatment of these models for the many advantages that the Bayesian framework offers in the mixture model context. Mainly it avoids the ill-posed nature of maximum likelihood due to the presence of singularities in the likelihood function. A mixture component may collapse by becoming centered at a single data vector sending its covariance to 0 and the model likelihood to infinity. A Bayesian treatment protects the algorithm from this problem occurring in ordinary EM. Also, Bayesian model comparison embodies the principle that states

that simple models should be preferred. Typically, maximum likelihood does not provide any guidance on the choice of the model order as more complex models can always fit the data better. For standard scale mixture of Gaussians, the usual Normal-Wishart prior can be used for the Gaussian parameters. For multiple scaled distributions, the specific decomposition of the covariance requires appropriate separated priors on the eigenvectors and eigenvalues of the scale matrix. Such a decomposition has been already examined in various works on priors for covariance matrix. In this work we consider several possibilities. We derive an inference scheme based on variational approximation and show how to apply this to model selection. In particular, we consider the issue of selecting automatically an appropriate number of classes in the mixtures. We show how to select this number from a single run avoiding the repetitive inference and comparison of all possible models.

6.2.5. *EM for Weighted-Data Clustering*

Participant: Florence Forbes.

Joint work with: Israel Gebru, Xavier Alameda-Pined and Radu Horaud from the Inria Perception team.

Data clustering has received a lot of attention and many methods, algorithms and software packages are currently available. Among these techniques, parametric finite-mixture models play a central role due to their interesting mathematical properties and to the existence of maximum-likelihood estimators based on expectation-maximization (EM). In this work we propose a new mixture model that associates a weight with each observed data point. We introduce a Gaussian mixture with weighted data and we derive two EM algorithms: the first one assigns a fixed weight to each observed datum, while the second one treats the weights as hidden variables drawn from gamma distributions. We provide a general-purpose scheme for weight initialization and we thoroughly validate the proposed algorithms by comparing them with several parametric and non-parametric clustering techniques. We demonstrate the utility of our method for clustering heterogeneous data, namely data gathered with different sensorial modalities, e.g., audio and vision. See also an application in [40].

6.3. Statistical models for Neuroscience

6.3.1. *Physiologically informed Bayesian analysis of ASL fMRI data*

Participants: Florence Forbes, Aina Frau Pascual, Thomas Vincent.

Joint work with: Philippe Ciuciu from Team Parietal and Neurospin, CEA in Saclay.

ASL fMRI data provides a quantitative measure of blood perfusion, that can be correlated to neuronal activation. In contrast to BOLD measure, it is a direct measure of cerebral blood flow. However, ASL data has a lower SNR and resolution so that the recovery of the perfusion response of interest suffers from the contamination by a stronger BOLD component in the ASL signal. In this work [38], [39] we consider a model of both BOLD and perfusion components within the ASL signal. A physiological link between these two components is analyzed and used for a more accurate estimation of the perfusion response function in particular in the usual ASL low SNR conditions.

6.3.2. *Physiological models comparison for the analysis of ASL fMRI data*

Participants: Florence Forbes, Aina Frau Pascual.

Joint work with: Philippe Ciuciu from Team Parietal and Neurospin, CEA in Saclay.

Physiological models have been proposed to describe the processes that underlie the link between neural and hemodynamic activity in the brain. Among these, the Balloon model describes the changes in blood flow, blood volume and oxygen concentration when an hemodynamic response is ensuing neural activation. Next, a *BOLD signal model* links these variables to the measured BOLD signal. Taken together, these equations allow the precise modeling of the coupling between the cerebral blood flow (CBF) and hemodynamic response (HRF). However, several competing versions of BOLD signal model have been described in the past. In this work, we compare different physiological models linking CBF to HRF and different BOLD signal models too in terms of least squares error and log-likelihood, and we assess the impact of this setting in the context of Arterial Spin Labelling (ASL) functional Magnetic Resonance Imaging (fMRI) data analysis.

6.3.3. Variational EM for the analysis of ASL fMRI data

Participants: Florence Forbes, Aina Frau Pascual.

Joint work with: Philippe Ciuciu from Team Parietal and Neurospin, CEA in Saclay.

In this work, the goal is to analyse ASL data by accounting jointly for both the BOLD and perfusion components in the signal. Using the model proposed in [77], we design a variational EM approach to estimate the model parameters as a faster alternative to the MCMC approach used in [77] and [39].

6.3.4. Metaheuristics for the analysis of fMRI data

Participants: Florence Forbes, Pablo Mesejo Santiago.

Joint work with: Jan Warnking from Grenoble Institute of Neuroscience.

The undergoing work is focused on the optimization of nonlinear models for fMRI data analysis, specially Blood-oxygen-level dependent (BOLD) MR modality. The current optimization procedure consists of a Bayesian inversion of the nonlinear model using a Gauss-Newton/Expectation-Maximization algorithm. Such an optimization procedure is time-consuming and achieves sub-optimal results. Therefore, the current research work is mainly focused on improving these results by experimenting with global search optimization methods, like metaheuristics (MHs). Secondly, MHs can also be of great help in the development of minimization algorithms for solving problems with orthogonality constraints (like in polynomial optimization, combinatorial optimization, eigenvalue problems, sparse PCA, matrix rank minimization, etc.). Thus, another main research line is concerned with the application of MHs to this problem and, if necessary, the design and implementation of new evolutionary operators that preserve orthogonality. And, finally, we are also trying to create advanced statistical models for coupling Arterial Spin Labeling (ASL) and BOLD MR modalities to study brain function.

6.3.5. Model selection for hemodynamic brain parcellation in fMRI

Participant: Florence Forbes.

Joint work with: Lotfi Chaari, Mohanad Albughdadi, Jean-Yves Tourneret from IRIT-ENSEEIH in Toulouse and Philippe Ciuciu from Neurospin, CEA in Saclay.

Brain parcellation into a number of hemodynamically homogeneous regions (parcels) is a challenging issue in fMRI analyses. This task has been recently integrated in the joint detection-estimation (JDE) resulting in the so-called joint detection-parcellation-estimation (JPDE) model. JPDE automatically estimates the parcels from the fMRI data but requires the desired number of parcels to be fixed. This is potentially critical in that the chosen number of parcels may influence detection-estimation performance. In this paper [30], we propose a model selection procedure to automatically fix the number of parcels from the data. The selection procedure relies on the calculation of the free energy corresponding to each concurrent model, within the variational expectation maximization framework. Experiments on synthetic and real fMRI data demonstrate the ability of the proposed procedure to select an adequate number of parcels. We also investigated the use of Latent Dirichlet Processes.

6.3.6. Partial volume estimation in brain MRI revisited

Participant: Florence Forbes.

Joint work with: Alexis Roche from Siemens Advanced Clinical Imaging Technology, Department of Radiology, CHUV, Signal Processing Laboratory (LTS5), EPFL, Lausanne, Switzerland.

Image-guided diagnosis of brain disease calls for accurate morphometry algorithms, e.g., in order to detect focal atrophy patterns relating to early-stage progression of particular forms of dementia. To date, widely used brain morphometry packages rest upon discrete Markov random field (MRF) image segmentation models that ignore, or do not fully account for partial voluming, leading to potentially inaccurate estimation of tissue volumes. Although several partial volume (PV) estimation methods have been proposed in the literature from the early 90's, none of them seems to be in common use. In [43], we propose a fast algorithm to estimate brain tissue concentrations from conventional T1-weighted images based on a Bayesian maximum a posteriori

formulation that extends the "mixel" model developed in the 90's. A key observation is the necessity to incorporate additional prior constraints to the "mixel" model for the estimation of plausible concentration maps. Experiments on the ADNI standardized dataset show that global and local brain atrophy measures from the proposed algorithm yield enhanced diagnosis testing value than with several widely used soft tissue labeling methods.

6.3.7. Tumor classification and prediction using robust multivariate clustering of multiparametric MRI

Participants: Florence Forbes, Alexis Arnaud.

Joint work with: Emmanuel Barbier and Benjamin Lemasson from Grenoble Institute of Neuroscience.

Advanced statistical clustering approaches are promising tools to better exploit the wealth of MRI information especially on large cohorts and multi-center studies. In neuro-oncology, the use of multiparametric MRI may better characterize brain tumor heterogeneity. To fully exploit multiparametric MRI (e.g. tumor classification), appropriate analysis methods are yet to be developed. They offer improved data quality control by allowing automatic outlier detection and improved analysis by identifying discriminative tumor signatures with measurable predictive power. In this work, we show on small animals data that advanced statistical learning approaches can help 1) in organizing existing data by detecting and excluding outliers and 2) in building a dictionary of tumor fingerprints from a clustering analysis of their microvascular features. Future work should include the integration in a joint statistical model of both automatic ROI delineation and clustering for whole brain data analysis, with a better use of anatomical information. This work has been submitted to the ISMRM 2015 conference and accepted in the SFMRMB 2015 conference [45].

6.4. Markov models

6.4.1. Identifying Interactions between Tropical Plant Species: A Correlation Analysis of High-Throughput Environmental DNA Sequence Data based on Random Matrix Theory

Participants: Florence Forbes, Angelika Studeny.

This is joint work with: Eric Coissac and Pierre Taberlet from LECA (Laboratoire d'Ecologie Alpine) and Alain Viari from Inria team Bamboo.

The study of species cooccurrence pattern has always been central to community ecology. The rise of high-throughput molecular methods and their use in ecology nowadays allows for a facilitated access to new data of an unprecedented quantity. We address the question about the identification of genuine species interactions in the light of these novel data. The statistical analysis has to be tailored to the data specifics: the large amount of available data as well as biases inherent to the data extraction methods. The latter can cause spurious interactions while the former complicates any statistical modelling approach. In addition, the resolution of the data provided is rarely on the species level. In this work, we conduct a thorough correlation analysis between MOTUs (molecular operating taxonomic unit) on different spatial scales to investigate global as well as local spatial pattern. Although this type of analysis is per se exploratory, we suggest it here in order to separate true species interaction from random pattern and to identify species subgroups for further in detail modelling. A random-matrix approach allows us to derive objective cut-off values for genuine correlations. We compare the results with those derived by the application of a model-based, sparse regression approach. Our study shows that despite their seemingly less precise nature when it comes to species identification, these data enable us to reveal mechanisms that structure an ecological community. In the light of the nowadays facilitated access to molecular data, this points the way to a novel set of efficient methods for community analysis.

6.4.2. Modelling multivariate counts with graphical Markov models.

Participant: Jean-Baptiste Durand.

Joint work with: Pierre Fernique (Montpellier 2 University, CIRAD and Inria Virtual Plants) and Yann Guédon (CIRAD and Inria Virtual Plants)

Multivariate count data are defined as the number of items in different states issued from sampling within a population, which individuals own items in various numbers and states. The analysis of multivariate count data is a recurrent and crucial issue in numerous modelling problems, particularly in the fields of biology and ecology (where the data can represent, for example, children counts associated with multitype branching processes), sociology and econometrics. Denoting by K the number of states, multivariate count data analysis relies on modelling the joint distribution of the K -dimensional random vector $N = (N_0, \dots, N_{K-1})$ with discrete components. Our work focused on I) Identifying states that appear simultaneously, or on the contrary that are mutually exclusive. This was achieved by identifying conditional independence relationships between the K variables; II) Building parsimonious parametric models consistent with these relationships; III) Characterizing and testing the effects of covariates on the distribution of N , particularly on the dependencies between its components.

Our context of application was characterised by zero-inflated, often right skewed marginal distributions. Thus, Gaussian and Poisson distributions were not *a priori* appropriate. Moreover, the multivariate histograms typically had many cells, most of which were empty. Consequently, nonparametric estimation was not efficient.

We developed an approach based on probabilistic graphical models (Koller & Friedman, 2009 [73]) to identify and exploit properties of conditional independence between numbers of children in different states, so as to simplify the specification of their joint distribution. The considered models are based on chain graphs. Model selection procedures are necessary to infer the graph and specify parsimonious distributions. The graph building stage was based on exploring the space of possible chain graph models, which required defining a notion of neighbourhood of these graphs. A parametric distribution was associated with each graph. It was obtained by combining families of univariate and multivariate distributions or regression models. These families were chosen by selection model procedures among different parametric families [36]. To relax the strong constraints regarding dependencies induced by using parametric distributions, mixture of graphical models were also considered [49].

Further extensions will be considered, and particularly

- Hidden Markov tree models (see 6.4.3) where the hidden state process is a multitype branching process with graphical generation distributions.
- Gaussian chain graph models, where the chain components can be identified using lasso methods.

6.4.3. *Statistical characterization of tree structures based on Markov tree models and multitype branching processes, with applications to tree growth modelling.*

Participant: Jean-Baptiste Durand.

Joint work with: Pierre Fernique (Montpellier 2 University and CIRAD) and Yann Guédon (CIRAD), Inria Virtual Plants.

Algorithmic issues in hidden Markov tree models were considered by Durand *et al.* (2004) [68]. This family of models was used to represent local dependencies and heterogeneity within tree-structured data. It relied on a tree-structured hidden state process, where the children states were assumed independent given their parent state. The latter assumption has been relaxed in an extension of these models and new algorithmic solutions for model inference have been proposed in Pierre Fernique's PhD [70]. An application to the study of the cell lineage in biological tissues responsible for the plant growth has been considered. In this setting, the number of children is small (between 0 and 2) and a saturated model has been considered to model transitions between parent and configurations of children states. Extensions will be proposed, based on the parametric discrete multivariate distributions developed in Section 6.4.2 .

6.4.4. *Change-point models for tree-structured data*

Participant: Jean-Baptiste Durand.

Joint work with: Pierre Fernique (Montpellier 2 University and CIRAD) and Yann Guédon (CIRAD), Inria Virtual Plants.

As an alternative to the hidden Markov tree models discussed in Section 6.4.3, subtrees with similar attributes can be identified using multiple change-point models. These approaches are well-developed in the context of sequence analysis, but their extensions to tree-structured data are not straightforward. Their advantage on hidden Markov models is to relax the strong constraints regarding dependencies induced by parametric distributions and local parent-children dependencies. Heuristic approaches for change-point detection in trees were proposed and applied to the analysis of patchiness patterns (consisting of canopies made of clumps of either vegetative or flowering botanical units) in mango trees [70].

6.4.5. *Hidden Markov models for the analysis of eye movements*

Participant: Jean-Baptiste Durand.

Joint work with: Anne Guérin-Dugué (GIPSA-lab) and Benoit Lemaire (Laboratoire de Psychologie et Neurocognition)

In the last years, GIPSA-lab has developed computational models of information search in web-like materials, using data from both eye-tracking and electroencephalograms (EEGs). These data were obtained from experiments, in which subjects had to make some kinds of press reviews. In such tasks, reading process and decision making are closely related. Statistical analysis of such data aims at deciphering underlying dependency structures in these processes. Hidden Markov models (HMMs) have been used on eye movement series to infer phases in the reading process that can be interpreted as steps in the cognitive processes leading to decision. In HMMs, each phase is associated with a state of the Markov chain. The states are observed indirectly through eye-movements. Our approach was inspired by Simola *et al.* (2008) [76], but we used hidden semi-Markov models for better characterization of phase length distributions. The estimated HMM highlighted contrasted reading strategies (i.e., state transitions), with both individual and document-related variability.

However, the characteristics of eye movements within each phase tended to be poorly discriminated. As a result, high uncertainty in the phase changes arose, and it could be difficult to relate phases to known patterns in EEGs.

As a perspective, we aim at developing an integrated model coupling EEG and eye movements within one single HMM for better identification of the phases. Here, the coupling should incorporate some delay between the transitions in both (EEG and eye-movement) chains, since EEG patterns associated to cognitive processes occur lately with respect to eye-movement phases. Moreover, EEGs and scanpaths were recorded with different time resolutions, so that some resampling scheme must be added into the model, for the sake of synchronizing both processes. Probabilistic graphical models (see Section 6.4.2) will be inferred from the channel correlations to represent interactions between brain zones. The variability of these graphs is partly explained by individual differences in text exploration, which will have to be quantified.

6.4.6. *Hyper-Spectral Image Analysis with Partially-Latent Regression and Spatial Markov Dependencies*

Participant: Florence Forbes.

Joint work with: Antoine Deleforge, Siley Ba and Radu Horaud from the Inria Perception team.

Hyper-spectral data can be analyzed to recover physical properties at large planetary scales. This involves resolving inverse problems which can be addressed within machine learning, with the advantage that, once a relationship between physical parameters and spectra has been established in a data-driven fashion, the learned relationship can be used to estimate physical parameters for new hyper-spectral observations. Within this framework, we propose a spatially-constrained and partially-latent regression method which maps high-dimensional inputs (hyper-spectral images) onto low-dimensional responses (physical parameters). The proposed regression model comprises two key features. Firstly, it combines a Gaussian mixture of locally-linear mappings (GLLiM) with a partially-latent response model described in [17]. While the former makes high-dimensional regression tractable, the latter enables to deal with physical parameters that cannot be observed or, more generally, with data contaminated by experimental artifacts that cannot be explained with

noise models. Secondly, spatial constraints are introduced in the model through a Markov random field (MRF) prior which provides a spatial structure to the Gaussian-mixture hidden variables. Experiments conducted on a database composed of remotely sensed observations collected from the Mars planet by the Mars Express orbiter demonstrate the effectiveness of the proposed model. A preliminary version of the work can be found in [31].

6.5. Semi and non-parametric methods

6.5.1. Conditional extremal events

Participant: Stéphane Girard.

Joint work with: L. Gardes (Univ. Strasbourg), A. Daouia (Univ. Toulouse I and Univ. Catholique de Louvain), J. Elmethni (Univ. Paris 5) and S. Louhichi (Univ. Grenoble 1)

The goal of the PhD thesis of Alexandre Lekina was to contribute to the development of theoretical and algorithmic models to tackle conditional extreme value analysis, *ie* the situation where some covariate information X is recorded simultaneously with a quantity of interest Y . In such a case, the tail heaviness of Y depends on X , and thus the tail index as well as the extreme quantiles are also functions of the covariate. We combine nonparametric smoothing techniques [71] with extreme-value methods in order to obtain efficient estimators of the conditional tail index and conditional extreme quantiles. The strong consistency of such estimator is established in [53]. When the covariate is functional and random (random design) we focus on kernel methods [58].

Conditional extremes are studied in climatology where one is interested in how climate change over years might affect extreme temperatures or rainfalls. In this case, the covariate is univariate (time). Bivariate examples include the study of extreme rainfalls as a function of the geographical location. The application part of the study is joint work with the LTHE (Laboratoire d'étude des Transferts en Hydrologie et Environnement) located in Grenoble.

6.5.2. Estimation of extreme risk measures

Participant: Stéphane Girard.

Joint work with: E. Deme (Univ. Gaston-Berger, Sénégal), J. Elmethni (Univ. Paris 5), L. Gardes and A. Guillou (Univ. Strasbourg)

One of the most popular risk measures is the Value-at-Risk (VaR) introduced in the 1990's. In statistical terms, the VaR at level $\alpha \in (0, 1)$ corresponds to the upper α -quantile of the loss distribution. The Value-at-Risk however suffers from several weaknesses. First, it provides us only with a pointwise information: $\text{VaR}(\alpha)$ does not take into consideration what the loss will be beyond this quantile. Second, random loss variables with light-tailed distributions or heavy-tailed distributions may have the same Value-at-Risk. Finally, Value-at-Risk is not a coherent risk measure since it is not subadditive in general. A coherent alternative risk measure is the Conditional Tail Expectation (CTE), also known as Tail-Value-at-Risk, Tail Conditional Expectation or Expected Shortfall in case of a continuous loss distribution. The CTE is defined as the expected loss given that the loss lies above the upper α -quantile of the loss distribution. This risk measure thus takes into account the whole information contained in the upper tail of the distribution. It is frequently encountered in financial investment or in the insurance industry. In [52], we have established the asymptotic properties of the CTE estimator in case of extreme losses, *ie* when $\alpha \rightarrow 0$ as the sample size increases. We have exhibited the asymptotic bias of this estimator, and proposed a bias correction based on extreme-value techniques. In [20], we study the situation where some covariate information is available. We thus have to deal with conditional extremes (see paragraph 6.5.1). We also proposed a new risk measure (called the Conditional Tail Moment) which encompasses various risk measures, such as the CTE, as particular cases.

6.5.3. Multivariate extremal events

Participants: Stéphane Girard, Gildas Mazo, Florence Forbes.

Joint work with: C. Amblard (TimB in TIMC laboratory, Univ. Grenoble I), L. Gardes (Univ. Strasbourg) and L. Menneteau (Univ. Montpellier II)

Copulas are a useful tool to model multivariate distributions [75]. At first, we developed an extension of some particular copulas [1]. It followed a new class of bivariate copulas defined on matrices [55] and some analogies have been shown between matrix and copula properties.

However, while there exist various families of bivariate copulas, much fewer has been done when the dimension is higher. To this aim an interesting class of copulas based on products of transformed copulas has been proposed in the literature. The use of this class for practical high dimensional problems remains challenging. Constraints on the parameters and the product form render inference, and in particular the likelihood computation, difficult. We proposed a new class of high dimensional copulas based on a product of transformed bivariate copulas [64]. No constraints on the parameters refrain the applicability of the proposed class which is well suited for applications in high dimension. Furthermore the analytic forms of the copulas within this class allow to associate a natural graphical structure which helps to visualize the dependencies and to compute the likelihood efficiently even in high dimension. The extreme properties of the copulas are also derived and an R package has been developed.

As an alternative, we also proposed a new class of copulas constructed by introducing a latent factor. Conditional independence with respect to this factor and the use of a nonparametric class of bivariate copulas lead to interesting properties like explicitness, flexibility and parsimony. In particular, various tail behaviours are exhibited, making possible the modeling of various extreme situations [42]. A pairwise moment-based inference procedure has also been proposed and the asymptotic normality of the corresponding estimator has been established [66].

In collaboration with L. Gardes, we investigate the estimation of the tail copula which is widely used to describe the amount of extremal dependence of a multivariate distribution. In some situations such as risk management, the dependence structure can be linked with some covariate. The tail copula thus depends on this covariate and is referred to as the conditional tail copula. The aim of our work is to propose a nonparametric estimator of the conditional tail copula and to establish its asymptotic normality [57].

6.5.4. Level sets estimation

Participant: Stéphane Girard.

Joint work with: A. Guillou and L. Gardes (Univ. Strasbourg), A. Nazin (Univ. Moscou), G. Stupfler (Univ. Aix-Marseille) and A. Daouia (Univ. Toulouse I and Univ. Catholique de Louvain)

The boundary bounding the set of points is viewed as the larger level set of the points distribution. This is then an extreme quantile curve estimation problem. We proposed estimators based on projection as well as on kernel regression methods applied on the extreme values set, for particular set of points [10]. We also investigate the asymptotic properties of existing estimators when used in extreme situations. For instance, we have established in collaboration with G. Stupfler that the so-called geometric quantiles have very counter-intuitive properties in such situations [63], [62] and thus should not be used to detect outliers. These results are submitted for publication.

In collaboration with A. Daouia, we investigate the application of such methods in econometrics [16]: A new characterization of partial boundaries of a free disposal multivariate support is introduced by making use of large quantiles of a simple transformation of the underlying multivariate distribution. Pointwise empirical and smoothed estimators of the full and partial support curves are built as extreme sample and smoothed quantiles. The extreme-value theory holds then automatically for the empirical frontiers and we show that some fundamental properties of extreme order statistics carry over to Nadaraya's estimates of upper quantile-based frontiers.

In collaboration with A. Nazin, we define new estimators of the frontier function based on linear programming methods. The frontier is defined as the solution of a linear optimization problem under inequality constraints. The estimator is shown to be strongly consistent with respect to the L_1 norm and we establish that it reaches the optimal minimax rate of convergence [58].

In collaboration with G. Stupfler and A. Guillou, new estimators of the boundary are introduced. The regression is performed on the whole set of points, the selection of the “highest” points being automatically performed by the introduction of high order moments [22].

6.5.5. Retrieval of Mars surface physical properties from OMEGA hyperspectral images.

Participants: Stéphane Girard, Alessandro Chiancone.

Joint work with: S. Douté from Laboratoire de Planétologie de Grenoble, J. Chanussot (Gipsa-lab and Grenoble-INP) and J. Saracco (Univ. Bordeaux).

Visible and near infrared imaging spectroscopy is one of the key techniques to detect, to map and to characterize mineral and volatile (eg. water-ice) species existing at the surface of planets. Indeed the chemical composition, granularity, texture, physical state, etc. of the materials determine the existence and morphology of the absorption bands. The resulting spectra contain therefore very useful information. Current imaging spectrometers provide data organized as three dimensional hyperspectral images: two spatial dimensions and one spectral dimension. Our goal is to estimate the functional relationship F between some observed spectra and some physical parameters. To this end, a database of synthetic spectra is generated by a physical radiative transfer model and used to estimate F . The high dimension of spectra is reduced by Gaussian regularized sliced inverse regression (GRSIR) to overcome the curse of dimensionality and consequently the sensitivity of the inversion to noise (ill-conditioned problems) [15]. We have also defined an adaptive version of the method which is able to deal with block-wise evolving data streams [13].

In his PhD thesis work, Alessandro Chiancone studies the extension of the SIR method to different sub-populations. The idea is to assume that the dimension reduction subspace may not be the same for different clusters of the data [46]. He also published a paper on a previous work in the field of hierarchical segmentation of images [14].

MODAL Project-Team

6. New Results

6.1. Highlights of the Year

Thanks to the development technological action MPAGenomics, the team has created one of the first french instances of Galaxy publicly available on the French Bioinformatics cloud. This instance is original as it offers complex statistical tools for genomic data analysis in a user-friendly interface (see 5.9).

The team obtained bilateral contracts with companies as Auchan or RougeGorge thanks to its just emerging, but promising, clustering software MixtComp (see 5.14), dedicated to full mixed and missing data.

6.2. Model for conditionally correlated categorical data

Participants: Christophe Biernacki, Matthieu Marbac-Lourdelle, Vincent Vandewalle.

An extension of the latent class model is proposed for clustering categorical data by relaxing the classical class conditional independence assumption of variables. In this model (called CCM for Conditional Correlated Model), variables are grouped into inter-independent and intra-dependent blocks in order to consider the main intra-class correlations. The dependence between variables grouped into the same block is taken into account by mixing two extreme distributions, which are respectively the independence and the maximum dependence ones. In the conditionally correlated data case, this approach is expected to reduce biases involved by the latent class model and to produce a meaningful model with few additional parameters. The parameters estimation by maximum likelihood is performed by an EM algorithm while a MCMC algorithm avoiding combinatorial problems involved by the block structure search is used for model selection. Applications on sociological and biological data sets bring out the proposed model interest. These results strengthen the idea that the proposed model is meaningful and that biases induced by the conditional independence assumption of the latent class model are reduced. This work has been now accepted in an international journal [24]. Furthermore, an R package (Clustericat) is available on CRAN (see 5.3).

6.3. Model for conditionally correlated categorical data

Participants: Christophe Biernacki, Matthieu Marbac-Lourdelle, Vincent Vandewalle.

It is a model-based clustering proposal (called CMM for Conditional Modes Model) where categorical data are grouped into conditionally independent blocks. The corresponding block distribution is a parsimonious multinomial distribution where the few free parameters correspond to the most likely modality crossings, while the remaining probability mass is uniformly spread over the other modality crossings. The exact computation of the integrated complete-data likelihood allows to perform the model selection, by a Gibbs sampler, reducing the computing time consuming by parameter estimation and avoiding BIC criterion biases pointed out by our experiments. An article has been now submitted to an international journal [49]. Furthermore, an R package (CoModes) is available on Rforge (see 5.4).

6.4. Mixture model for mixed kind of data

Participants: Christophe Biernacki, Matthieu Marbac-Lourdelle, Vincent Vandewalle.

A mixture model of Gaussian copula allows to cluster mixed kind of data. Each component is composed by classical margins while the conditional dependencies between the variables is modeled by a Gaussian copula. The parameter estimation is performed by a Gibbs sampler. An article has been presented to an international conference [48] and has been also submitted to an international journal [50]. Furthermore, an R package (MixCluster) is available on Rforge (see 5.12).

6.5. Mixture of Gaussians with Missing Data

Participants: Christophe Biernacki, Vincent Vandewalle.

The generative models allow to handle missing data. This can be easily performed by using the EM algorithm, which has a closed form M-step in the Gaussian setting. This can for instance be useful for distance estimation with missing data. It has been proposed to improve the distance estimation by fitting a mixture of Gaussian distributions instead of a considering only one Gaussian component [16]. This is a joint work with Emil Eirola and Amaury Lendresse .

6.6. Clustering and variable selection in regression

Participants: Christophe Biernacki, Loïc Yengo, Julien Jacques.

A new framework is proposed to address the issue of simultaneous linear regression and clustering of predictors where regression coefficients are assumed to be drawn from a Gaussian mixture distribution. Prediction is thus performed using the conditional distribution of the regression coefficients given the data, while clusters are easily derived from posterior distribution in groups given the data. This work is now published in [27]. Furthermore, an R package (clere) is available on Rforge (see 5.2) and an improved version of the initial model has been submitted to an international journal [52].

6.7. Model-based clustering for multivariate partial ranking data

Participants: Christophe Biernacki, Julien Jacques.

The first model-based clustering algorithm dedicated to multivariate partial ranking data is now published in an international journal [19]. This is an extension of the (ISR) model for ranking data published in 2013. The proposed algorithm has allowed to exhibit regional alliances between European countries in the Eurovision contest, which are often suspected but never proved.

6.8. Generative models for correlated variables in regression

Participants: Christophe Biernacki, Clément Théry.

Linear regression outcomes (estimates, prevision) are known to be damaged by highly correlated covariates. However most modern datasets are expected to mechanically convey more and more highly correlated covariates due to the global increase of the amount of variables they contain. We propose to explicitly model such correlations by a family of linear regressions between the covariates. It leads to a particular generative model through the distribution explicitly introduced between correlated covariates. It has been presented to a conference [32] and is currently written as a research paper [51]. Furthermore, an R package (CorReg) is available on CRAN (see 5.5). Extension is now available for missing covariables also. It is a joint work with Gaétan Loridant.

6.9. Model-based clustering for multivariate partial ordinal data

Participants: Christophe Biernacki, Julien Jacques.

We design the first univariate probability distribution for ordinal data which strictly respects the ordinal nature of data. More precisely, it relies only on order comparisons between modalities, the proposed distribution being obtained by modeling the data generating process which is assumed, from optimality arguments, to be a stochastic binary search algorithm in a sorted table. The resulting distribution is natively governed by two meaningful parameters (position and precision) and has very appealing properties: decrease around the mode, shape tuning from uniformity to a Dirac, identifiability. Moreover, it is easily estimated by an EM algorithm since the path in the stochastic binary search algorithm is missing. Using then the classical latent class assumption, the previous univariate ordinal model is straightforwardly extended to model-based clustering for multivariate ordinal data. Again, parameters of this mixture model are estimated by an EM algorithm. Both simulated and real data sets illustrate the great potential of this model by its ability to parsimoniously identify particularly relevant clusters which were unsuspected by some traditional competitors. This work is currently in revision in an international journal [38].

6.10. Clustering for functional data into discriminative subspaces

Participant: Julien Jacques.

This is a joint work with Charles Bouveyron (Paris 5) and Etienne Côme (Inrets).

A model-based clustering method for time series has been developed, based on a discriminative functional mixture model which allows the clustering of the data in a functional subspace. This model presents the advantage to be parsimonious and can therefore handle long time series. This model has been used for analyzing different bike sharing systems In Europe.

6.11. Degeneracy in multivariate Gaussian mixtures

Participant: Christophe Biernacki.

In the case of Gaussian mixtures, unbounded likelihood is an important theoretical and practical problem. Using the weak information that the latent sample size of each component has to be greater than the space dimension, we derive a simple non-asymptotic stochastic lower bound on variances. We prove also that maximizing the likelihood under this data-driven constraint leads to consistent estimates. This work has been presented to a conference [31]. This is a joint work with Gwënaelle Castellán.

6.12. Auto-Associative Models

Participant: Serge Iovleff.

Auto-Associative models cover a large class of methods used in data analysis, among them are for example the famous PCA and the auto-associative neural networks. We describe the general properties of these models when the projection component is linear and we propose and test an easy to implement Probabilistic Semi-Linear Auto-Associative model in a Gaussian setting. This work is now published in [18].

6.13. Resampling and density estimation

Participant: Alain Celisse.

We characterized the behavior of cross-validation (L_{po}) in density estimation with the L^2 -loss. We considered two aspects: risk estimation and model selection. For the first one, we settled leave-one-out is optimal. On the contrary for the second one, we provided the first guidelines toward an optimal choice of the parameter p . In particular, this choice depends on the convergence rate of the best estimator in the family we consider.

6.14. Resampling and classification

Participant: Alain Celisse.

This is a joint work with Tristan Mary-Huard (INRA).

We extended known results about leave-one-out to the case of leave- p -out for the k -nearest neighbor estimator in classification with the 0-1 loss. In particular, our strategy relies on the relationship between leave- p -out and U-statistics. We derive upper bounds on the moments on the leave- p -out estimator as well as an exponential concentration inequality.

6.15. Kernel change-point

Participants: Alain Celisse, Guillemette Marot.

This is a joint work with Guillem Rigail and Morgane Pierre-Jean (Univ. Evry).

Based on a previous work, we successfully applied kernel methods to change-point detection in the context of next generation sequencing with multivariate complex data. We also provided greatly improved algorithm in terms of computational complexity (both in time and space). With very huge amounts of data, we also suggest a new strategy based on the idea of approximating the Gram matrix by a low-rank matrix, which leads to a linear time complexity algorithm.

6.16. Normality test in RKHS

Participants: Alain Celisse, Jérémie Kellner.

In the kernel method framework, we use the MMD (maximum mean discrepancy) to derive a new goodness-of-fit test that can be used in the RKHS. When applied to the usual R^d setting, our test does not seem too sensitive to any increase on the dimension d unlike other ongoing approaches. With an infinite dimension RKHS, it exhibits a good power for a prescribed level of type-I error control.

6.17. Differential meta-analysis of RNA-seq data from multiple studies

Participant: Guillemette Marot.

This is a joint work with Andrea Rau and Florence Jaffrézic (INRA, Jouy-en-Josas).

An adaptation of meta-analysis methods initially proposed for microarray studies has been proposed for RNA-seq data. The research paper has been published in [26] and the associated R package metaRNASeq is now available on CRAN (see 5.11).

6.18. Multi-patient analysis of genomic markers

Participants: Quentin Grimonprez, Samuel Blanck, Guillemette Marot, Alain Celisse.

Tests performed during Development Technological Action MPAGenomics have shown on real data that it was also important to suggest automatic and appropriate calibrations for parameters in segmentation methods than to look for common markers able to predict patient's response. In the R package MPAGenomics (see 5.15), we have thus proposed two independent pipelines described in [17]. The choice of a given pipeline depends on the heterogeneity degree of studied genomic profiles.

6.19. Scan statistics for dependent data

Participants: Alexandru Amarioarei, Cristian Preda.

Dependent models of type block factors are introduced for scan statistics as an extension of the models based on the independent and identically distributed assumption. Approximations and errors are derived for one and two dimensions. Matlab software has been developed for this purpose.

REALOPT Project-Team

6. New Results

6.1. Highlights of the Year

- Olivier Beaumont and Lionel Eyraud-Dubois have received the HiPC best paper award for their work on resource allocation for large scale virtualized platforms with reliability guarantees. They provided a formulation based on a thorough analysis of a real life usage trace, and a very efficient two-step allocation algorithm.
- The team organized the annual conference of the French Operations Research Society ROADEF14 in Feb 2014.
- An Inria Innovation Lab has been created between Realoft and Ertus Consulting.
- The SAMBA associated team project with Brazil was renewed for 3 years including new collaborators from Chili.
- François Vanderbeck was invited as a plenary speaker at the conference OPTIMIZATION 2014, in Portugal [19].

6.2. Automation and combination of linear-programming based stabilization techniques in column generation

We reviewed in [88] stabilization techniques that can improve in practice the convergence of a column generation algorithm. Proximal methods based on penalising the deviation from the incumbent dual solution have become standards of the domain. However, the analysis of such methods is important to understand the mechanism on which they rely, to appreciate the difference between methods, and to derive intelligent schemes to adjust their parameters. As stabilization procedures for column generation can be viewed as cutting plane strategies in the dual problem, the link with cutting plane separation strategies can be exploited to enlarge the scope of methods and to refine their analysis. In [24], [40], we focus on stabilization schemes that rely solely on a linear programming (LP) solver for the column generation master program. This restrictive scope captures the most common implementations where one uses an LP solver to handle the master program. For dual price smoothing techniques, we analyse the link with the in-out separation strategy and we derive generic convergence properties. For penalty function methods as well as for smoothing, we describe proposals for parameter self-adjusting schemes. Such schemes make initial parameter tuning less of an issue as corrections are made. Also, the dynamic adjustments, compared to a static setting, allows to adapt the parameters to the phase of the algorithm. We provide extensive test reports that highlight the comparative performances of such scheme and validate our self-adjusting parameter scheme. Furthermore, our results show that using smoothing in combination with penalty function yields a cumulative effect on convergence speed-ups [35]. We have also consider other stabilization strategies inspired form algorithmic strategies have been designed to accelerate convergence of cutting plane algorithms in mixed integer programming. In [37], we show that the "Multi-Point Separation" strategy translates into a column generation stabilization technique that consists in restricting the dual solution to be in the convex hull of the selected multi-point set. We have also considered other stabilization strategies inspired from algorithmic strategies that have been designed to accelerate convergence of cutting plane algorithms in mixed integer programming. In [37], we show that the "Multi-Point Separation" strategy translates into a column generation stabilization technique that consists in restricting the dual solution to be in the convex hull of the selected multi-point set.

6.3. Multi-Stage Column generation strategies

In [39], we propose another mechanism to improve the performance of column generation algorithms. We study the application of branch-and-price approaches to the automatic version of the Software Clustering Problem. To tackle this problem, we apply the Dantzig-Wolfe decomposition to a formulation from literature. Given this, we present two Column Generation (CG) approaches to solve the linear programming relaxation of the resulting reformulation: the standard CG approach, and a new approach, which we call Staged Column Generation (SCG). Also, we propose a modification to the pricing subproblem that allows to add multiple columns at each iteration of the CG. We test our algorithms in a set of 45 instances from the literature. The proposed approaches were able to improve the literature results solving all these instances to optimality. Furthermore, the SCG approach presented a considerable performance improvement regarding computational time, number of iterations and generated columns when compared with the standard CG as the size of the instances grows.

6.4. Aggregation techniques to reduce the size of column generation models

We proposed an aggregation method to reduce the size of column generation (CG) models for a class of set-covering problems in which the feasible subsets depend on a resource constraint. The aggregation relies on a correlation between the resource consumption of the elements and the corresponding optimal dual values. The aggregated model obtained allows to find good quality lower bounds more rapidly than the original CG algorithm. The speedup is due to less primal and dual variables in the master, and to an aggregated pricing sub-problem. To guarantee optimality, we designed an algorithm that iteratively refines the aggregation until the CG optimum is reached. Computational results prove the usefulness of our methods.

6.5. Dual-feasible functions

Dual-feasible functions have been used in the past to compute fast lower bounds and valid inequalities for different combinatorial optimization and integer programming problems. Until now, all the dual-feasible functions proposed in the literature were 1-dimensional functions, and were defined only for positive arguments. In [12] we extended the principles of dual-feasible functions to the m -dimensional case by introducing the concept of vector packing dual-feasible function. We explored the theoretical properties of these functions in depth, and we proposed general schemes for generating some instances of these functions. Additionally, we proposed and analyzed different new families of vector packing dual-feasible functions. All the proposed approaches were tested extensively using benchmark instances of the 2-dimensional vector packing problem. Our computational results showed that these functions can approximate very efficiently the best lower bounds for this problem. In a second paper, currently submitted to a journal, we show that extending these functions to negative arguments raises many issues. Additionally, we describe different construction principles to obtain dual-feasible functions with domain and range \mathbb{R} . Specific instances obtained from these principles are proposed and analyzed.

6.6. Resource Allocation and Scheduling in Large Scale Distributed Platforms.

We have considered several problems arising in the context of large scale platforms, that are characterized by their heterogeneity, the difficulty of predicting performance and the risk failures. In [13], we concentrate on heterogeneity issues in collective communication schemes where the goal is to broadcast a message to a set of nodes. In particular, we consider a realistic model in the context of large scale distributed platforms where some nodes may lie behind NATs or firewalls and may be therefore unable to forward the message between them. In [21], [20], we consider resource allocation problems that arise in large scale data centers. In [20], we analyze the main characteristics of the services in a huge trace corresponding to an actual data center and that has been released recently by google. In the same context, in [21], we concentrate on issues related to fault tolerance by over subscribing services in order to guarantee quality of service in a failure prone environment. At last, the difficulty to predict the actual performance of resources made it very popular to rely on dynamic scheduling algorithms where scheduling decisions are made at runtime. In [22], we analyze the performance of such a dynamic scheduling algorithm in terms on number of induced communications for outer product and matrix multiplication kernels.

6.7. Employee timetabling with time varying demand

We addressed a multi-activity tour scheduling problem with time varying demand. The objective is to compute a schedule for a fixed roster in order to minimize the over-coverage and the under-coverage of different parallel activity demands along a planning horizon. Numerous complicating constraints are present in our problem: all employees are different and can perform several different activities during the same day-shift, lunch breaks and pauses are flexible, demand is given for 15 minutes periods. To the best of our knowledge, the work in [29] is the first attempt to combine days-off scheduling, shift scheduling, shift assignment, activity assignment, pause and lunch break assignment. To solve this problem, we developed several methods: a compact linear Mixed Integer Programming model, a branch-and-price like approach with a nested dynamic program to solve heuristically the subproblems, a diving heuristic, and a greedy heuristic based on our subproblem solver. The computational results, based on both real cases and instances derived from real cases, demonstrate that our methods are able to provide good quality solutions in a short computing time. Our algorithms are now embedded in a commercial software, which is already in use in a mini-mart company.

6.8. Time-dependent formulations for routing problems

The paper [16] presents a new formulation for the Time-Dependent Travelling Salesman Problem (TDTSP). We start by reviewing well known natural formulations with some emphasis on the formulation by Picard and Queyranne (1978). The main feature of this formulation is that it uses, as a subproblem, an exact description of the n -circuit problem. Then, we present a new formulation that uses more variables and is based on using, for each node, a stronger subproblem, namely a n -circuit subproblem with the additional constraint that the corresponding node is not repeated in the circuit. Although the new model has more variables and constraints than the original PQ model, the results given from our computational experiments show that the linear programming relaxation of the new model gives, for many of the instances tested, gaps that are close to zero. Thus, the new model is worth investigating for solving TDTSP instances. We have also provided a complete characterization of the feasible set of the corresponding linear programming relaxation in the space of the variables of the PQ model. This characterization permits us to suggest alternative methods of using the proposed formulations.

A well-known formulation for the unit-demand capacitated vehicle routing problem uses a single commodity flow system to represent the delivery of the items. The vehicle capacity is modeled by imposing a maximum capacity on the arcs used by the flow. In [30], we used a time-dependent formulation for the problem to derive, by projection, tighter bounding inequalities on the arcs. The first experiments show that these new inequalities permit to improve significantly the linear relaxation bound of the single commodity flow formulation. We are currently studying separation algorithms in order to generate dynamically these new inequalities.

6.9. Vehicle routing for dial-a-ride problems

Static and deterministic vehicle routing problems cannot be used in many real-life systems, as input data are not reliable and revealed over time. In [11], we study a pickup and delivery problem with time windows accounting for maximum ride time constraints – the so-called dial-a-ride problem – in its static and dynamic variant, and we make specific proposal on robust optimization models for this problem. To solve the static model, we develop a branch-and-price approach that handles ride time constraints in the process of generating feasible vehicle routes in the course of the optimization procedure. The work is focussed on the pricing problem solver and acceleration techniques for the branch-and-price approach. Our numerical results show that the method is competitive compared to existing approaches that are based on branch-and-cut. In the dynamic context, where some input data are revealed or modified over time, we apply our branch-and-price algorithm for re-optimization in a rolling horizon approach.

6.10. A MILP approach to minimize the number of late jobs with and without machine availability constraints

The study in [14] investigates scheduling problems that occur when the weighted number of late jobs that are subject to deterministic machine availability constraints have to be minimized. These problems can be modeled as a more general job selection problem. Cases with resumable, non-resumable, and semi-resumable jobs as well as cases without availability constraints are investigated. The proposed efficient mixed integer linear programming approach includes possible improvements to the model, notably specialized lifted knapsack cover cuts. The method proves to be competitive compared with existing dedicated methods: numerical experiments on randomly generated instances show that all 350-job instances of the test bed are closed for the well-known problem $1|r_i|\sum w_i U_i$. For all investigated problem types, 98.4% of 500-job instances can be solved to optimality within one hour.

6.11. Two phase solution for an intelligent moving target search problem based on a 0–1 linear model

We developed a generic discrete model for the moving, intelligent target problem. Our objective is to maximise the probability of detection of the moving target with respect to target and searcher's constraints. The solution method proposed in [15] is composed of two stages. The first one aims at providing a large-scale strategy based on an Integer Linear Program approach. As a direct solution of this problem is not practically possible, we use a decomposition of the problem into a searcher's strategy on one side, and the target's strategy on the other side. A good strategy for the searcher is determined using a sliding window procedure. Concerning the target, our approach consists in simulating some of the target's possible strategies and considering each of these possibilities as an independent and deterministic entity. The second stage is dedicated to adjusting the large-scale strategy provided by stage 1. Numerical results are presented so as to assess the impact of our approach.

6.12. Computing the Chromatic index and clique number of special graphs

In our paper [17] on the strong chromatic index of planar graphs with large girth, we prove that every planar graph with maximum degree Δ (let Δ be an integer) and girth at least $10\Delta + 46$ is strong $(2\Delta - 1)$ -edge-colorable, that is best possible (in terms of number of colors) as soon as G contains two adjacent vertices of degree Δ . This improves the best previous result when $\Delta \geq 6$. In [18] we show how one can compute the clique number of a -perfect graphs in polynomial time. A main result of combinatorial optimization is that clique and chromatic number of a perfect graph are computable in polynomial time (Grötschel, Lovasz and Schrijver 1981). This result relies on polyhedral characterizations of perfect graphs involving the stable set polytope of the graph, a linear relaxation defined by clique constraints, and a semi-definite relaxation, the Theta-body of the graph. A natural question is whether the algorithmic results for perfect graphs can be extended to graph classes with similar polyhedral properties. In [18] we consider a superclass of perfect graphs, the a -perfect graphs, whose stable set polytope is given by constraints associated with generalized cliques. We show that for such graphs the clique number can be computed in polynomial time as well. The result strongly relies upon Fulkerson's antiblocking theory for polyhedra and Lovasz's Theta function.

SELECT Project-Team

6. New Results

6.1. Model selection in Regression and Classification

Participants: Gilles Celeux, Serge Cohen, Clément Levrard, Erwan Le Pennec, Pascal Massart, Nelo Molter Magalhaes, Lucie Montuelle.

Unsupervised segmentation is an issue similar to unsupervised classification with an added spatial aspect. Functional data is acquired on points in a spatial domain and the goal is to segment the domain in homogeneous domain. The range of applications includes hyperspectral images in conservation sciences, fMRI data and all spatialized functional data. Erwan Le Pennec and Lucie Montuelle are focusing on the questions of the way to handle the spatial component from both the theoretical and the practical point of views. They study in particular the choice of the number of clusters. Furthermore, as functional data require heavy computation, they are required to propose numerically efficient algorithms. With Serge Cohen and an X intern some progress have been made on the use of logistic weights in the hyperspectral setting.

Lucie Montuelle has studied a model of mixture of Gaussian regressions in which the proportions are modeled using logistic weights. Using maximum likelihood estimators, a model selection procedure has been applied, supported by a theoretical guarantee. Numerical experiments have been conducted for regression mixtures with parametric logistic weights, using EM and Newton algorithms. This work is published in Electronic Journal of Statistics.

Another subject considered by Erwan Le Pennec and Lucie Montuelle was the obtention of oracle inequalities in deviation for model selection aggregation in the fixed design regression framework. Exponential weights are widely used but sub-optimal. They aggregate linear estimators and penalize Stein's unbiased risk estimate used in exponential weights to derive such inequalities. Furthermore if the infinity norm of the regression function is known and taken into account in the penalty, then a sharp oracle inequality is available. Pac-Bayesian tools and concentration inequalities play a key role in this work. These results may be found in a prepublication on arxiv or in Lucie Montuelle's PhD thesis.

In collaboration with Sylvain Arlot, Matthieu Lerasle and Patricia Reynaud-Bourret (CNRS) Nelo Molter Magalhaes considers estimator selection problem with the L^2 loss. They provide a theoretical minimal and optimal penalty. They define practical cross-validation procedures and provide non-asymptotic and first order optimal results for these procedures.

Emilie Devijver and Pascal Massart focused on the Lasso for high dimension finite mixture regression models. An ℓ_1 oracle inequality have been get for this estimator for this model, for a specific regularization parameter. Moreover, for maximum likelihood estimators, restricted to relevant variables and to low rank, theoretical results have been proved to support methodology.

Pascal Massart and Clément Levrard continue their work on the properties of the k -means algorithm in collaboration with Gérard Biau (Université Paris 6). Most of the work achieved this year was devoted to the obtention of fast convergence rates for the k -means quantizer of a source distribution in the high-dimensional case. It has been proved that the margin condition for vector quantization introduced last year can be extended to the infinite dimensional Hilbert case, and that this condition is sufficient for the source distribution to satisfy some natural properties, such as the finiteness of the set of optimal quantizers. When this condition is satisfied, a dimension-free fast convergence rate can be derived. In addition, this margin condition provides theoretical guarantees for methods combining k -means and variable selection through a Lasso-type procedure. Its implementation is still in process, however early experiments shows that this procedure can retrieve active variables in the Gaussian mixture case.

Among selection methods for nonparametric estimators, a recent one is the procedure of Goldenshluger-Lespi. This method proposes a data-driven choice of m to select an estimator among a collection $(\hat{s}_m)_{m \in M}$. The selected \hat{m} is chosen as a minimiser of $B(m) + V(m)$ where $B(m) = \sup\{[\|\hat{s}_m - \hat{s}_{m'}\| - V(m')]\}_+$, $m' \in M$ and $V(m)$ is a penalty term to be suitably chosen. Previous results have established oracle inequalities to ensure that if $V(m)$ is large enough the final estimator $\hat{s}_{\hat{m}}$ is almost as efficient as the best one in the collection. The aim of the work of Claire Lacour and Pascal Massart was to give a practical way to calibrate $V(m)$. To do this they have evidenced an explosion phenomenon: if V is chosen smaller than some critical V_0 , the risk $\|s - \hat{s}_{\hat{m}}\|$ is proven to dramatically increase, though for $V > V_0$ this risk is quasi-optimal. Simulations have corroborated this behavior.

The well-documented and consistent variable selection procedure in model-based cluster analysis and classification, that Cathy Maugis (INSA Toulouse) has designed during her PhD. thesis in SELECT, makes use of stepwise algorithms which are painfully slow in high dimensions. In order to circumvent this drawback, Gilles Celeux in collaboration with Mohammed Sedki (Université Paris XI) and Cathy Maugis), proposed to sort the variables using a lasso-like penalization adapted to the Gaussian mixture model context. Using this rank to select the variables they avoid the combinatory problem of stepwise procedures. After tests on challenging simulated and real data sets, their algorithm finalised and show good performances.

In collaboration with Jean-Michel Marin (Université de Montpellier) and Olivier Gascuel (LIRMM), Gilles Celeux has continued a research aiming to select a short list of models rather a single model. This short list of models is declared to be compatible with the data using a p -value derived from the Kullback-Leibler distance between the model and the empirical distribution. And, the Kullback-Leibler distances at hand are estimated through non parametric and parametric bootstrap procedures.

6.2. Statistical learning methodology and theory

Participants: Vincent Brault, Gilles Celeux, Christine Keribin, Erwan Le Pennec, Lucie Montuelle, Michel Prenat, Solenne Thivin.

Vincent Brault, Ph D. student of Gilles Celeux and Christine Keribin defended his thesis on the Latent Block Model (LBM) for categorical data. Their work investigated a Gibbs algorithm to avoid solutions with empty clusters on synthetic as well as real data (Congressional Voting Records and genomic data). They detailed the link between the information criteria ICL and BIC, compared them on synthetic and real data, and conjectured that these criteria are both consistent for LBM, which is not a standard behavior. Hence, ICL has to be preferred for LBM. This work is now published in *Statistics and Computing*.

Vincent Brault has achieved a detailed bibliographical review on coclustering with Aurore Lomet (UTC) which is currently under revision. He has also worked in collaboration with Mahindra Mariadassou (INRA) to overview the state of the art on theoretical results for latent or stochastic block model.

Vincent Brault, Christine Keribin and Mahindra Mariadassou have started a collaboration to tackle the consistency and asymptotic normality for the maximum likelihood and variational estimators in a stochastic or latent block model.

Gilles Celeux has started a collaboration with Jean-Patrick Baudry on strategies to avoid the traps of the EM algorithm in mixture analysis. They analyse the effect of the spurious local maximizers and the regularized algorithms to avoid these spurious solutions. They explore the link of the degree of regularization and the slope heuristics. Moreover, they propose and study strategies to initiate the EM algorithm embedding the solution with K components and the starting position with $K + 1$ component to avoid suboptimal solutions.

Erwan Le Pennec is supervising Solenne Thivin in her CIFRE with Michel Prenat and Thales Optronique. The aim is target detection on complex background such as clouds or sea. Their approach is a local approach based on test decision theory. They have obtained theoretical and numerical results on a segmentation based approach in which a simple Markov field testing procedure is used in each cell of a data driven partition. They also have obtained experimental results on images (or patches) unsupervised classification, with the aim of better calibrate the detection procedure. The classification is based on features which are defined in cloud texture modeling activity.

Erwan Le Pennec and Michel Prenat have also collaborated on a cloud texture modeling using a non-parametric approach. Such a modeling could be used to better calibrate the detection procedure: it can lead to more examples than the one acquired and it could be the basis of an ensemble method.

6.3. Reliability

Participants: Yves Auffray, Gilles Celeux, Rémy Fouchereau, Patrick Pamphile, Jana Kalawoun.

In 2014, in the framework of a CIFRE convention with Snecma-SAFRAN Rémy Fouchereau has defended a thesis on the modeling of fatigue lifetime supervised by Gilles Celeux and Patrick Pamphile. In aircraft, space and nuclear industry, fatigue test is the main basic tool for analyzing fatigue lifetime of a given material, component, or structure. A sample of the material is subjected to cyclic loading S (stress, force, strain, etc.), by a testing machine which counts N , the number of cycles to failure. Fatigue test results are plotted on a SN-curve. A probabilistic model for the construction of SN-curve is proposed. In general, fatigue test results are widely scattered for High Cycle Fatigue region and "duplex" SN-curves appears for Very High Cycle region. That is why classic models from mechanic of rupture theory on one hand, probability theory on the other hand, do not fit SN-curve on the whole range of cycles. We have proposed a probabilistic model, based on a fracture mechanic approach: few parameters are required and they are easily interpreted by mechanic or material engineers. This model has been applied to both simulated and real fatigue test data sets. The SN-curves have been well fitted on the whole range of cycles. The parameters have been estimated using the EM algorithm, combining Newton-Raphson optimisation method and Monte Carlo integral estimations. The model has been then improved taking into account production process information, thanks to a clustering approach. Thus, we have provided engineers with a probabilistic tool for reliability design of mechanical parts, but also with a diagnostic tool for material elaboration.

Since two years SELECT collaborates with CEA for the estimation of the battery State of Charge (SoC). For vehicles powered by an electric motor, SoC estimation is essential to guarantee vehicle autonomy, as well as safe utilization. The aim is to create a reliable SoC model to closely fit the battery dynamic, in embedded applications (e.g. Electric Vehicle). Jana Kalawoun started a thesis supervised by Gilles Celeux, Patrick Pamphile and Maxime Montaru (CEA) on this topic. The SoC is modeled by a Switching Markov State-Space Model. The parameters are estimated by combining the EM algorithm and Particle Filter methods. The model is validated using real-life electric vehicle data. It has been proved to be highly superior to a simple state space model. The optimal number of battery modes is then identified, using different model selection criteria as BIC or the slope heuristics.

Yves Auffray and Gilles Celeux proposed a solution to a reliability problem on Dassault's F7X business jet brakes. As the origin brake version showed poor reliability performance, an increased frequency inspection of the brakes had been decided and, after a while, a new brake version adopted. The new version has not shown any failure since its adoption. Then the question was : is it possible to relax the brakes inspection frequency ? On the basis of first brake version failure data, the parameters of a Weibull law was estimated : $\eta = 3169, \beta = 1.38$. Under the hypothesis that the new brake version would follow the same Weibull law, the probability that none of them broke was $1.67 \cdot 10^{-6}$. This led to reject that hypothesis.

A Weibull model for the new brakes was then estimated. The shape parameter being leaved conservatively unchanged, the scale parameter was estimated so that the no failure event probability amounts to 0.05. This led to $\eta = 9326$.

From the resulting Weibull model, dates $D_0, D_1, \dots, D_k, \dots$ of inspection for the new brakes was established so that : $\mathbb{P}(T \leq D_0 + D_1 + \dots + D_k | T > D_0 + \dots + D_{k-1}) = 0.01$.

Dassault has adopted this far less constraining inspection calendar.

6.4. Statistical analysis of genomic data

Participants: Vincent Brault, Gilles Celeux, Méлина Gallopin, Christine Keribin, Yann Vasseur.

In collaboration with Florence Jaffrezic and Andrea Rau (INRA, animal genetic department), Méлина Gallopin is a third year PhD student under the supervision of Gilles Celeux. This thesis is concerned with the modelization and model selection in the analysis of RNA-seq data. This year, they proposed a model selection criterion for model-based clustering of annotated gene expression data. This criterion is a ICL-like criterion taking into account the annotations. They are also working on a objective comparison of discrete and continuous modelling after a transformations for RNA-seq data based on a comparison of the likelihoods (eventually penalized) of the models in competition.

The subject of Yann Vasseur PhD Thesis, supervised by Gilles Celeux and Marie-Laure Martin-Magniette (INRA URGV), is the inference of a regulatory network on Transcriptions Factors (TFs), which are specific genes, of *Arabidopsis thaliana*. In that purpose, a transcriptome dataset with a sensibly equal size of TFS and statistical units is available. The first aim consists of reducing the dimension of the network to avoid high dimension difficulties. Representing this network with a Gaussian Graphical Model, the following procedure has been defined:

1. *Selection step*: choosing the set of TFs regulators (supports) of each TF.
2. *Classification step*: deducing co-factors groups (TFs with similiary expression levels) from these supports.

Thus, the reduced network would be built on the co-factors groups. Currently, several selection methods based on Gauss-LASSO and resampling procedures have been applied on the dataset. The study of the stability and the parameters calibration of these methods are in progress. The TFs are clustered with the Latent Block Model in a number of co-factors groups selected with the BIC or the exact ICL criterion.

In collaboration with Marie-Laure Martin-Magniette, Cathy Maugis and Andrea Rau, Gilles Celeux studied gene expression gotten from high-throughput sequencing technology. They focus on the question of clustering digital gene expression profiles as a means to discover groups of co-expressed genes. They propose a Poisson mixture model using a rigorous framework for parameter estimation as well as the choice of the appropriate number of clusters. They illustrate co-expression analyses using this approach on two real RNA-seq datasets. A set of simulation studies also compares the performance of the proposed model with that of several related approaches developed to cluster RNA-seq or serial analysis of gene expression data. The proposed method is implemented in the open-source R package `HTSCluster`, available on CRAN.

6.5. Model based-clustering for pharmacovigilance data

Participants: Gilles Celeux, Christine Keribin, Valérie Robert.

In collaboration with Pascale Tubert-Bitter, Ismael Ahmed and Mohamed Sedki, Gilles Celeux and Christine Keribin has started a research concerning the detection of associations between drugs and adverse events in the framework of the PhD of Valerie Robert. At first, this team has developed a model-based clustering inspired of the latent black model which consists in co-clustering rows and columns of two binary tables imposing the same row ranking. Then it enables to highlight subgroups of individuals sharing the same drug profile and subgroups of adverse effects and drugs with strong interaction. Besides, some sufficient conditions are provided to obtain the identifiability of the model and some studies are experimented on simulated data.

6.6. Curves classification, denoising and forecasting

Participants: Émilie Devijver, Pascal Massart, Jean-Michel Poggi, Vincent Thouvenot.

In collaboration with Farouk Mhamdi and Meriem Jaidane (ENIT, Tunis, Tunisia), Jean-Michel Poggi proposed a method for trend extraction from seasonal time series through the Empirical Mode Decomposition (EMD). Experimental comparison of trend extraction based on EMD, X11, X12 and Hodrick Prescott filter are conducted. First results show the eligibility of the blind EMD trend extraction method. Tunisian real peak load is also used to illustrate the extraction of the intrinsic trend.

Jean-Michel Poggi, co-supervising with Anestis Antoniadis (Université Joseph Fourier Grenoble) the PhD thesis of Vincent Thouvenot, funded by a CIFRE with EDF. The industrial motivation of this work is the recent development of new technologies for measuring power consumption by EDF to acquire consumption data for different mesh network. The thesis will focus on the development of new statistical methods for predicting power consumption by exploiting the different levels of aggregation of network data collection. From the mathematical point of view, the work is to develop generalized additive models for this type of kind of aggregated data for the modeling of functional data, associating closely nonparametric estimation and variable selection using various penalization methods.

Jean-Michel Poggi and Pascal Massart are the co-advisors of the PhD thesis of Émilie Devijver, strongly motivated by the same kind of industrial forecasting problems in electricity, which is dedicated to curves clustering for the prediction. A natural framework to explore this question is mixture of regression models for functional data. They extend to functional data the recent work by Bühlmann and coauthors dealing with the simultaneous estimation of mixture regression models in the scalar case using Lasso type methods. It is based on the technical tools of the work of Caroline Meynet (which completes her thesis Orsay under the direction of P. Massart), which deals with the clustering of functional data using Lasso methods choosing simultaneously number of clusters and selecting significant wavelet coefficients. Nevertheless, they also propose a procedure dealing with low rank estimator. Simulations and benchmark data have been conducted for high-dimensional finite mixture regression models.

Jean-Michel Poggi, co-supervising with Meriem Jaëdane, Raja Ghozi (ENIT Tunisie) and from the industrial side, Sylvie Sevestre-Ghalila (CEA LinkLab), the PhD thesis of Neska El Haouij, funded by a kind of CIFRE with CEA LinkLab. The industrial motivation of this work is the recent development of new technologies for sensory measurements, environmental and physiological to explain and improve the driving tasks. The thesis aims to explain sensory aspects involved in automated decision to the car interior, by objectivization. The thesis will focus on the use and development of experimental designs and statistical methods to quantify and explain driving ability in to the modeling using functional explanatory factors. Statistical contributions of this work will involve nonparametric estimation and variable selection and/or models.

6.7. Statistical analysis of medical images

Participants: Christine Keribin, Yves Rozenholc.

Yves Rozenholc and C. Keribin work the genomic tumoral alterations and supervised a Master student Yi LIU. The study of genomic DNA alterations (recurrent regions of alteration, patterns of instability) contributes to tumor classification, and becomes of great importance for the personalization of cancer treatments. The use of Single-Nucleotide Polymorphism (SNP) arrays or of New Generation Sequences (NGS) techniques allows the simultaneous estimation of segmented copy number (CN) and B-allele frequency (BAF) profiles along the whole genome. In this context, Popova (2009) proposed the GAP method, based on pattern recognition with (BAF, CN) maps to detect genotype status of each segment in complex tumoral genome profiles. It takes into account the fact that the observations on these maps are necessarily placed on centers that depend –up to a proper scaling of the CN– only on the unknown proportion of non tumoral tissue in the sample. Being deterministic and manually tuned, this method appears sensitive to noise. To overcome this drawback, they set a mixture model, allowing the automatic estimation of the proportion of non tumoral tissue and the test of genotype for each segment along the whole genome. They develop the estimation with an adapted EM algorithm that has been tested on simulated data. This work has already been presented (ERCIM 14, SEQBIO14) and provides many potential developments.

SEQUEL Project-Team

6. New Results

6.1. Highlights of the Year

- New startup by Rémi Coulom on AI in games (go, chess, mahjong, ...).
- Successful Collaboration with Deezer and the victory at the ACM RecSys Recommendation Systems Challenge
- We were selected and working on preparation of ICML 2015 in Lille. ICML is the most important conference in the field of machine learning. This is the first time after more than 30 years of existence, that this conference will be held in France.

6.2. Decision-making Under Uncertainty

6.2.1. Reinforcement Learning

Selecting Near-Optimal Approximate State Representations in Reinforcement Learning [23]

We consider a reinforcement learning setting where the learner does not have explicit access to the states of the underlying Markov decision process (MDP). Instead, she has access to several models that map histories of past interactions to states. Here we improve over known regret bounds in this setting, and more importantly generalize to the case where the models given to the learner do not contain a true model resulting in an MDP representation but only approximations of it. We also give improved error bounds for state aggregation.

Online Stochastic Optimization under Correlated Bandit Feedback [15]

In this paper we consider the problem of online stochastic optimization of a locally smooth function under bandit feedback. We introduce the high-confidence tree (HCT) algorithm, a novel anytime X -armed bandit algorithm, and derive regret bounds matching the performance of state-of-the-art algorithms in terms of the dependency on number of steps and the near-optimality dimension. The main advantage of HCT is that it handles the challenging case of correlated bandit feedback (reward), whereas existing methods require rewards to be conditionally independent. HCT also improves on the state-of-the-art in terms of the memory requirement, as well as requiring a weaker smoothness assumption on the mean-reward function in comparison with the existing anytime algorithms. Finally, we discuss how HCT can be applied to the problem of policy search in reinforcement learning and we report preliminary empirical results.

Sparse Multi-task Reinforcement Learning [9]

In multi-task reinforcement learning (MTRL), the objective is to simultaneously learn multiple tasks and exploit their similarity to improve the performance w.r.t. single-task learning. In this paper we investigate the case when all the tasks can be accurately represented in a linear approximation space using the same small subset of the original (large) set of features. This is equivalent to assuming that the weight vectors of the task value functions are *jointly sparse*, i.e., the set of their non-zero components is small and it is shared across tasks. Building on existing results in multi-task regression, we develop two multi-task extensions of the fitted Q -iteration algorithm. While the first algorithm assumes that the tasks are jointly sparse in the given representation, the second one learns a transformation of the features in the attempt of finding a more sparse representation. For both algorithms we provide a sample complexity analysis and numerical simulations.

6.2.2. Multi-arm Bandit Theory

Spectral Bandits for Smooth Graph Functions with Applications in Recommender Systems [20]

Smooth functions on graphs have wide applications in manifold and semi-supervised learning. In this paper, we study a bandit problem where the payoffs of arms are smooth on a graph. This framework is suitable for solving online learning problems that involve graphs, such as content-based recommendation. In this problem, each recommended item is a node and its expected rating is similar to its neighbors. The goal is to recommend items that have high expected ratings. We aim for the algorithms where the cumulative regret would not scale poorly with the number of nodes. In particular, we introduce the notion of an effective dimension, which is small in real-world graphs, and propose two algorithms for solving our problem that scale linearly in this dimension. Our experiments on real-world content recommendation problem show that a good estimator of user preferences for thousands of items can be learned from just tens nodes evaluations.

Online combinatorial optimization with stochastic decision sets and adversarial losses [21]

Most work on sequential learning assumes a fixed set of actions that are available all the time. However, in practice, actions can consist of picking subsets of readings from sensors that may break from time to time, road segments that can be blocked or goods that are out of stock. In this paper we study learning algorithms that are able to deal with stochastic availability of such unreliable composite actions. We propose and analyze algorithms based on the Follow-The-Perturbed-Leader prediction method for several learning settings differing in the feedback provided to the learner. Our algorithms rely on a novel loss estimation technique that we call Counting Asleep Times. We deliver regret bounds for our algorithms for the previously studied full information and (semi-)bandit settings, as well as a natural middle point between the two that we call the restricted information setting. A special consequence of our results is a significant improvement of the best known performance guarantees achieved by an efficient algorithm for the sleeping bandit problem with stochastic availability. Finally, we evaluate our algorithms empirically and show their improvement over the known approaches.

Extreme bandits [10]

In many areas of medicine, security, and life sciences, we want to allocate limited resources to different sources in order to detect extreme values. In this paper, we study an efficient way to allocate these resources sequentially under limited feedback. While sequential design of experiments is well studied in bandit theory, the most commonly optimized property is the regret with respect to the maximum mean reward. However, in other problems such as network intrusion detection, we are interested in detecting the most extreme value output by the sources. Therefore, in our work we study extreme regret which measures the efficiency of an algorithm compared to the oracle policy selecting the source with the heaviest tail. We propose the ExtremeHunter algorithm, provide its analysis, and evaluate it empirically on synthetic and real-world experiments.

Efficient learning by implicit exploration in bandit problems with side observations [18]

We consider online learning problems under a partial observability model capturing situations where the information conveyed to the learner is between full information and bandit feedback. In the simplest variant, we assume that in addition to its own loss, the learner also gets to observe losses of some other actions. The revealed losses depend on the learner's action and a directed observation system chosen by the environment. For this setting, we propose the first algorithm that enjoys near-optimal regret guarantees without having to know the observation system before selecting its actions. Along similar lines, we also define a new partial information setting that models online combinatorial optimization problems where the feedback received by the learner is between semi-bandit and full feedback. As the predictions of our first algorithm cannot be always computed efficiently in this setting, we propose another algorithm with similar properties and with the benefit of always being computationally efficient, at the price of a slightly more complicated tuning mechanism. Both algorithms rely on a novel exploration strategy called implicit exploration, which is shown to be more efficient both computationally and information-theoretically than previously studied exploration strategies for the problem.

Best-Arm Identification in Linear Bandits [29]

We study the best-arm identification problem in linear bandit, where the rewards of the arms depend linearly on an unknown parameter θ^* and the objective is to return the arm with the largest reward. We characterize the complexity of the problem and introduce sample allocation strategies that pull arms to identify the best arm with a fixed confidence, while minimizing the sample budget. In particular, we show the importance of exploiting the global linear structure to improve the estimate of the reward of near-optimal arms. We analyze the proposed strategies and compare their empirical performance. Finally, we point out the connection to the G -optimality criterion used in optimal experimental design.

Exploiting easy data in online optimization [28]

We consider the problem of online optimization, where a learner chooses a decision from a given decision set and suffers some loss associated with the decision and the state of the environment. The learner's objective is to minimize its cumulative regret against the best fixed decision in hindsight. Over the past few decades numerous variants have been considered, with many algorithms designed to achieve sub-linear regret in the worst case. However, this level of robustness comes at a cost. Proposed algorithms are often over-conservative, failing to adapt to the actual complexity of the loss sequence which is often far from the worst case. In this paper we introduce a general algorithm that, provided with a "safe" learning algorithm and an opportunistic "benchmark", can effectively combine good worst-case guarantees with much improved performance on "easy" data. We derive general theoretical bounds on the regret of the proposed algorithm and discuss its implementation in a wide range of applications, notably in the problem of learning with shifting experts (a recent COLT open problem). Finally, we provide numerical simulations in the setting of prediction with expert advice with comparisons to the state of the art.

Spectral Bandits for Smooth Graph Functions [32]

Smooth functions on graphs have wide applications in manifold and semi-supervised learning. In this paper, we study a bandit problem where the payoffs of arms are smooth on a graph. This framework is suitable for solving online learning problems that involve graphs, such as content-based recommendation. In this problem, each item we can recommend is a node and its expected rating is similar to its neighbors. The goal is to recommend items that have high expected ratings. We aim for the algorithms where the cumulative regret with respect to the optimal policy would not scale poorly with the number of nodes. In particular, we introduce the notion of an effective dimension, which is small in real-world graphs, and propose two algorithms for solving our problem that scale linearly and sublinearly in this dimension. Our experiments on real-world content recommendation problem show that a good estimator of user preferences for thousands of items can be learned from just tens of nodes evaluations.

Regret bounds for restless Markov bandits [5]

We consider the restless Markov bandit problem, in which the state of each arm evolves according to a Markov process independently of the learner's actions. We suggest an algorithm, that first represents the setting as an MDP which exhibits some special structural properties. In order to grasp this information we introduce the notion of ϵ -structured MDPs, which are a generalization of concepts like (approximate) state aggregation and MDP homomorphisms. We propose a general algorithm for learning ϵ -structured MDPs and show regret bounds that demonstrate that additional structural information enhances learning. Applied to the restless bandit setting, this algorithm achieves after any T steps regret of order $\tilde{O}(T^{1/2})$ with respect to the best policy that knows the distributions of all arms. We make no assumptions on the Markov chains underlying each arm except that they are irreducible. In addition, we show that index-based policies are necessarily suboptimal for the considered problem.

Spectral Thompson Sampling [19]

Thompson Sampling (TS) has surged a lot of interest due to its good empirical performance, in particular in the computational advertising. Though successful, the tools for its performance analysis appeared only recently. In this paper, we describe and analyze SpectralTS algorithm for a bandit problem, where the payoffs of the choices are smooth given an underlying graph. In this setting, each choice is a node of a graph and the expected payoffs of the neighboring nodes are assumed to be similar. Although the setting has application

both in recommender systems and advertising, the traditional algorithms would scale poorly with the number of choices. For that purpose we consider an effective dimension d , which is small in real-world graphs. We deliver the analysis showing that the regret of SpectralTS scales as $d(T \ln N)^{1/2}$ with high probability, where T is the time horizon and N is the number of choices. Since a $d \sqrt{T \ln N}$ regret is comparable to the known results, SpectralTS offers a computationally more efficient alternative. We also show that our algorithm is competitive on both synthetic and real-world data.

6.2.3. Recommendation systems

User Engagement as Evaluation: a Ranking or a Regression Problem? [39]

In this paper, we describe the winning approach used on the RecSys Challenge 2014 which focuses on employing user engagement as evaluation of recommendations. On one hand, we regard the challenge as a ranking problem and apply the LambdaMART algorithm, which is a listwise model specialized in a Learning To Rank approach. On the other hand, after noticing some specific characteristics of this challenge, we also consider it as a regression problem and use pointwise regression models such as Random Forests. We compare how these different methods can be modified or combined to improve the accuracy and robustness of our model and we draw the advantages or disadvantages of each approach.

Improving offline evaluation of contextual bandit algorithms via bootstrapping techniques [22]

In many recommendation applications such as news recommendation, the items that can be recommended come and go at a very fast pace. This is a challenge for recommender systems (RS) to face this setting. Online learning algorithms seem to be the most straight forward solution. The contextual bandit framework was introduced for that very purpose. In general the evaluation of a RS is a critical issue. Live evaluation is often avoided due to the potential loss of revenue, hence the need for offline evaluation methods. Two options are available. Model based methods are biased by nature and are thus difficult to trust when used alone. Data driven methods are therefore what we consider here. Evaluating online learning algorithms with past data is not simple but some methods exist in the literature. Nonetheless their accuracy is not satisfactory mainly due to their mechanism of data rejection that only allow the exploitation of a small fraction of the data. We precisely address this issue in this paper. After highlighting the limitations of the previous methods, we present a new method, based on bootstrapping techniques. This new method comes with two important improvements: it is much more accurate and it provides a measure of quality of its estimation. The latter is a highly desirable property in order to minimize the risks entailed by putting online a RS for the first time. We provide both theoretical and experimental proofs of its superiority compared to state-of-the-art methods, as well as an analysis of the convergence of the measure of quality.

Bandits Warm-up Cold Recommender Systems [35]

We address the cold start problem in recommendation systems assuming no contextual information is available neither about users, nor items. We consider the case in which we only have access to a set of ratings of items by users. Most of the existing works consider a batch setting, and use cross-validation to tune parameters. The classical method consists in minimizing the root mean square error over a training subset of the ratings which provides a factorization of the matrix of ratings, interpreted as a latent representation of items and users. Our contribution in this paper is 5-fold. First, we explicit the issues raised by this kind of batch setting for users or items with very few ratings. Then, we propose an online setting closer to the actual use of recommender systems; this setting is inspired by the bandit framework. The proposed methodology can be used to turn any recommender system dataset (such as Netflix, MovieLens,...) into a sequential dataset. Then, we explicit a strong and insightful link between contextual bandit algorithms and matrix factorization; this leads us to a new algorithm that tackles the exploration/exploitation dilemma associated to the cold start problem in a strikingly new perspective. Finally, experimental evidence confirm that our algorithm is effective in dealing with the cold start problem on publicly available datasets. Overall, the goal of this paper is to bridge the gap between recommender systems based on matrix factorizations and those based on contextual bandits.

6.2.4. Nonparametric statistics of time series

Uniform hypothesis testing for finite-valued stationary processes [6]

Given a discrete-valued sample X_1, \dots, X_n we wish to decide whether it was generated by a distribution belonging to a family H_0 , or it was generated by a distribution belonging to a family H_1 . In this work we assume that all distributions are stationary ergodic, and do not make any further assumptions (e.g. no independence or mixing rate assumptions). We would like to have a test whose probability of error (both Type I and Type II) is uniformly bounded. More precisely, we require that for each ϵ there exist a sample size n such that probability of error is upper-bounded by ϵ for samples longer than n . We find some necessary and some sufficient conditions on H_0 and H_1 under which a consistent test (with this notion of consistency) exists. These conditions are topological, with respect to the topology of distributional distance.

Asymptotically consistent estimation of the number of change points in highly dependent time series [17]

The problem of change point estimation is considered in a general framework where the data are generated by arbitrary unknown stationary ergodic process distributions. This means that the data may have long-range dependencies of an arbitrary form. In this context the consistent estimation of the number of change points is provably impossible. A formulation is proposed which overcomes this obstacle: it is possible to find the correct number of change points at the expense of introducing the additional constraint that the correct number of process distributions that generate the data is provided. This additional parameter has a natural interpretation in many real-world applications. It turns out that in this formulation change point estimation can be reduced to time series clustering. Based on this reduction, an algorithm is proposed that finds the number of change points and locates the changes. This algorithm is shown to be asymptotically consistent. The theoretical results are complemented with empirical evaluations.

6.3. Statistical Learning and Bayesian Analysis

6.3.1. Prediction of Sequences of Structured and Unstructured Data

Statistical performance analysis of a fast super-resolution technique using noisy translations [38]

It is well known that the registration process is a key step for super-resolution reconstruction. In this work, we propose to use a piezoelectric system that is easily adaptable on all microscopes and telescopes for controlling accurately their motion (down to nanometers) and therefore acquiring multiple images of the same scene at different controlled positions. Then a fast super-resolution algorithm can be used for efficient super-resolution reconstruction. In this case, the optimal use of r^2 images for a resolution enhancement factor r is generally not enough to obtain satisfying results due to the random inaccuracy of the positioning system. Thus we propose to take several images around each reference position. We study the error produced by the super-resolution algorithm due to spatial uncertainty as a function of the number of images per position. We obtain a lower bound on the number of images that is necessary to ensure a given error upper bound with probability higher than some desired confidence level.

Quantitative control of the error bounds of a fast super-resolution technique for microscopy and astronomy [11]

While the registration step is often problematic for super-resolution, many microscopes and telescopes are now equipped with a piezoelectric mechanical system which permits to accurately control their motion (down to nanometers). Therefore one can use such devices to acquire multiple images of the same scene at various controlled positions. Then a fast super-resolution algorithm [1] can be used for efficient super-resolution. However the minimal use of r^2 images for a resolution enhancement factor r is generally not sufficient to obtain good results. We propose to take several images at positions randomly distributed close to each reference position. We study the number of images necessary to control the error resulting from the super-resolution algorithm by [1] due to the uncertainty on positions. The main result is a lower bound on the number of images to respect a given error upper bound with probability higher than a desired confidence level.

6.3.2. Statistical analysis of superresolution

A diffusion strategy for distributed dictionary learning [12]

We consider the problem of a set of nodes which is required to collectively learn a common dictionary from noisy measurements. This distributed dictionary learning approach may be useful in several contexts including sensor networks. Diffusion cooperation schemes have been proposed to estimate a consensus solution to distributed linear regression. This work proposes a diffusion-based adaptive dictionary learning strategy. Each node receives measurements which may be shared or not with its neighbors. All nodes cooperate with their neighbors by sharing their local dictionary to estimate a common representation. In a diffusion approach, the resulting algorithm corresponds to a distributed alternate optimization. Beyond dictionary learning, this strategy could be adapted to many matrix factorization problems in various settings. We illustrate its efficiency on some numerical experiments, including the difficult problem of blind hyperspectral images unmixing.

6.4. Miscellaneous

6.4.1. Miscellaneous

Online Matrix Completion Through Nuclear Norm Regularisation [14]

It is the main goal of this paper to propose a novel method to perform matrix completion on-line. Motivated by a wide variety of applications, ranging from the design of recommender systems to sensor network localization through seismic data reconstruction, we consider the matrix completion problem when entries of the matrix of interest are observed gradually. Precisely, we place ourselves in the situation where the predictive rule should be refined incrementally, rather than recomputed from scratch each time the sample of observed entries increases. The extension of existing matrix completion methods to the sequential prediction context is indeed a major issue in the Big Data era, and yet little addressed in the literature. The algorithm promoted in this article builds upon the Soft Impute approach introduced in Mazumder et al. (2010). The major novelty essentially arises from the use of a randomised technique for both computing and updating the Singular Value Decomposition (SVD) involved in the algorithm. Though of disarming simplicity, the method proposed turns out to be very efficient, while requiring reduced computations. Several numerical experiments based on real datasets illustrating its performance are displayed, together with preliminary results giving it a theoretical basis.

Synthèse en espace et temps du rayonnement acoustique d'une paroi sous excitation turbulente par synthèse spectrale 2D+T et formulation vibro-acoustique directe [33]

Une méthode directe pour simuler les vibrations et le rayonnement acoustique d'une paroi soumise à un écoulement subsonique est proposée. Tout d'abord, en adoptant l'hypothèse d'un écoulement homogène et stationnaire, on montre qu'une méthode de synthèse spectrale en espace et temps (2D+t) est suffisante pour obtenir explicitement une réalisation d'un champ de pression pariétale excitatrice $p(x,y,t)$ dont les propriétés inter-spectrales sont prescrites par un modèle empirique de Chase. Cette pression turbulente $p(x,y,t)$ est obtenue explicitement et permet de résoudre le problème vibro-acoustique de la paroi dans une formulation directe. La méthode proposée fournit ainsi une solution complète du problème dans le domaine spatio-temporel : pression excitatrice, déplacement en flexion et pression acoustique rayonnée par la paroi. Une caractéristique de la méthode proposée est un coût de calcul qui s'avère similaire aux formulations inter-spectrales majoritairement utilisées dans la littérature. En particulier, la synthèse permet de prendre en compte l'intégralité des échelles spatio-temporelles du problème : échelles turbulentes, vibratoires et acoustiques. A titre d'exemple, la pression aux oreilles d'un auditeur suite à l'excitation turbulente de la paroi est synthétisée.

Bandits attack function optimization [27]

We consider function optimization as a sequential decision making problem under the budget constraint. Such constraint limits the number of objective function evaluations allowed during the optimization. We consider an algorithm inspired by a continuous version of a multi-armed bandit problem which attacks this optimization problem by solving the tradeoff between exploration (initial quasi-uniform search of the domain)

and exploitation (local optimization around the potentially global maxima). We introduce the so-called Simultaneous Optimistic Optimization (SOO), a deterministic algorithm that works by domain partitioning. The benefit of such an approach are the guarantees on the returned solution and the numerical efficiency of the algorithm. We present this machine learning rooted approach to optimization, and provide the empirical assessment of SOO on the CEC'2014 competition on single objective real-parameter numerical optimization test suite.

Optimistic planning in Markov decision processes using a generative model [30]

We consider the problem of online planning in a Markov decision process with discounted rewards for any given initial state. We consider the PAC sample complexity problem of computing, with probability $1-\delta$, an ϵ -optimal action using the smallest possible number of calls to the generative model (which provides reward and next-state samples). We design an algorithm, called StOP (for Stochastic-Optimistic Planning), based on the "optimism in the face of uncertainty" principle. StOP can be used in the general setting, requires only a generative model, and enjoys a complexity bound that only depends on the local structure of the MDP.

Near-Optimal Rates for Limited-Delay Universal Lossy Source Coding [3]

We consider the problem of limited-delay lossy coding of individual sequences. Here, the goal is to design (fixed-rate) compression schemes to minimize the normalized expected distortion redundancy relative to a reference class of coding schemes, measured as the difference between the average distortion of the algorithm and that of the best coding scheme in the reference class. In compressing a sequence of length T , the best schemes available in the literature achieve an $O(T^{-1/3})$ normalized distortion redundancy relative to finite reference classes of limited delay and limited memory, and the same redundancy is achievable, up to logarithmic factors, when the reference class is the set of scalar quantizers. It has also been shown that the distortion redundancy is at least of order $T^{-1/2}$ in the latter case, and the lower bound can easily be extended to sufficiently powerful (possibly finite) reference coding schemes. In this paper, we narrow the gap between the upper and lower bounds, and give a compression scheme whose normalized distortion redundancy is $O(\ln(T)/T^{1/2})$ relative to any finite class of reference schemes, only a logarithmic factor larger than the lower bound. The method is based on the recently introduced shrinking dartboard prediction algorithm, a variant of exponentially weighted average prediction. The algorithm is also extended to the problem of joint source-channel coding over a (known) stochastic noisy channel and to the case when side information is also available to the decoder (the Wyner–Ziv setting). The same improvements are obtained for these settings as in the case of a noiseless channel. Our method is also applied to the problem of zero-delay scalar quantization, where $O(\ln(T)/T^{1/2})$ normalized distortion redundancy is achieved relative to the (infinite) class of scalar quantizers of a given rate, almost achieving the known lower bound of order $1/T^{-1/2}$. The computationally efficient algorithms known for scalar quantization and the Wyner–Ziv setting carry over to our (improved) coding schemes presented in this paper.

Online Markov Decision Processes Under Bandit Feedback [4]

Software systems are composed of many interacting elements. A natural way to abstract over software systems is to model them as graphs. In this paper we consider software dependency graphs of object-oriented software and we study one topological property: the degree distribution. Based on the analysis of ten software systems written in Java, we show that there exists completely different systems that have the same degree distribution. Then, we propose a generative model of software dependency graphs which synthesizes graphs whose degree distribution is close to the empirical ones observed in real software systems. This model gives us novel insights on the potential fundamental rules of software evolution.

A Generative Model of Software Dependency Graphs to Better Understand Software Evolution [37]

Software systems are composed of many interacting elements. A natural way to abstract over software systems is to model them as graphs. In this paper we consider software dependency graphs of object-oriented software and we study one topological property: the degree distribution. Based on the analysis of ten software systems written in Java, we show that there exists completely different systems that have the same degree distribution. Then, we propose a generative model of software dependency graphs which synthesizes graphs whose degree

distribution is close to the empirical ones observed in real software systems. This model gives us novel insights on the potential fundamental rules of software evolution.

Preference-Based Rank Elicitation using Statistical Models: The Case of Mallows [8]

We address the problem of rank elicitation assuming that the underlying data generating process is characterized by a probability distribution on the set of all rankings (total orders) of a given set of items. Instead of asking for complete rankings, however, our learner is only allowed to query pairwise preferences. Using information of that kind, the goal of the learner is to reliably predict properties of the distribution, such as the most probable top-item, the most probable ranking, or the distribution itself. More specifically, learning is done in an online manner, and the goal is to minimize sample complexity while guaranteeing a certain level of confidence.

Preference-based reinforcement learning: evolutionary direct policy search using a preference-based racing algorithm [1]

We introduce a novel approach to preference-based reinforcement learning, namely a preference-based variant of a direct policy search method based on evolutionary optimization. The core of our approach is a preference-based racing algorithm that selects the best among a given set of candidate policies with high probability. To this end, the algorithm operates on a suitable ordinal preference structure and only uses pairwise comparisons between sample rollouts of the policies. Embedding the racing algorithm in a rank-based evolutionary search procedure, we show that approximations of the so-called Smith set of optimal policies can be produced with certain theoretical guarantees. Apart from a formal performance and complexity analysis, we present first experimental studies showing that our approach performs well in practice.

Biclique Coverings, Rectifier Networks and the Cost of ε -Removal [16]

We relate two complexity notions of bipartite graphs: the minimal weight biclique covering number $\text{Cov}(G)$ and the minimal rectifier network size $\text{Rect}(G)$ of a bipartite graph G . We show that there exist graphs with $\text{Cov}(G) \geq \text{Rect}(G)^{3/2-\delta}$. As a corollary, we establish that there exist nondeterministic finite automata (NFAs) with ε -transitions, having n transitions total such that the smallest equivalent ε -free NFA has $\Omega(n^{3/2-\delta})$ transitions. We also formulate a version of previous bounds for the weighted set cover problem and discuss its connections to giving upper bounds for the possible blow-up.

Efficient Eigen-updating for Spectral Graph Clustering [2]

Partitioning a graph into groups of vertices such that those within each group are more densely connected than vertices assigned to different groups, known as graph clustering, is often used to gain insight into the organisation of large scale networks and for visualisation purposes. Whereas a large number of dedicated techniques have been recently proposed for static graphs, the design of on-line graph clustering methods tailored for evolving networks is a challenging problem, and much less documented in the literature. Motivated by the broad variety of applications concerned, ranging from the study of biological networks to the analysis of networks of scientific references through the exploration of communications networks such as the World Wide Web, it is the main purpose of this paper to introduce a novel, computationally efficient, approach to graph clustering in the evolutionary context. Namely, the method promoted in this article can be viewed as an incremental eigenvalue solution for the spectral clustering method described by Ng. et al. (2001). The incremental eigenvalue solution is a general technique for finding the approximate eigenvectors of a symmetric matrix given a change. As well as outlining the approach in detail, we present a theoretical bound on the quality of the approximate eigenvectors using perturbation theory. We then derive a novel spectral clustering algorithm called Incremental Approximate Spectral Clustering (IASC). The IASC algorithm is simple to implement and its efficacy is demonstrated on both synthetic and real datasets modelling the evolution of a HIV epidemic, a citation network and the purchase history graph of an e-commerce website.

From Bandits to Monte-Carlo Tree Search: The Optimistic Principle Applied to Optimization and Planning [36]

This work covers several aspects of the optimism in the face of uncertainty principle applied to large scale optimization problems under finite numerical budget. The initial motivation for the research reported here originated from the empirical success of the so-called Monte-Carlo Tree Search method popularized in computer-go and further extended to many other games as well as optimization and planning problems. Our objective is to contribute to the development of theoretical foundations of the field by characterizing the complexity of the underlying optimization problems and designing efficient algorithms with performance guarantees. The main idea presented here is that it is possible to decompose a complex decision making problem (such as an optimization problem in a large search space) into a sequence of elementary decisions, where each decision of the sequence is solved using a (stochastic) multi-armed bandit (simple mathematical model for decision making in stochastic environments). This so-called hierarchical bandit approach (where the reward observed by a bandit in the hierarchy is itself the return of another bandit at a deeper level) possesses the nice feature of starting the exploration by a quasi-uniform sampling of the space and then focusing progressively on the most promising area, at different scales, according to the evaluations observed so far, and eventually performing a local search around the global optima of the function. The performance of the method is assessed in terms of the optimality of the returned solution as a function of the number of function evaluations. Our main contribution to the field of function optimization is a class of hierarchical optimistic algorithms designed for general search spaces (such as metric spaces, trees, graphs, Euclidean spaces, ...) with different algorithmic instantiations depending on whether the evaluations are noisy or noiseless and whether some measure of the "smoothness" of the function is known or unknown. The performance of the algorithms depend on the local behavior of the function around its global optima expressed in terms of the quantity of near-optimal states measured with some metric. If this local smoothness of the function is known then one can design very efficient optimization algorithms (with convergence rate independent of the space dimension), and when it is not known, we can build adaptive techniques that can, in some cases, perform almost as well as when it is known.

SIERRA Project-Team

5. New Results

5.1. An Optimal Affine Invariant Smooth Minimization Algorithm

Participant: Alexandre d’Aspremont.

We formulate an affine invariant implementation of the algorithm in Nesterov (1983). We show that the complexity bound is then proportional to an affine invariant regularity constant defined with respect to the Minkowski gauge of the feasible set. We also detail matching lower bounds when the feasible set is an ℓ_p ball. In this setting, our bounds on iteration complexity for the algorithm in Nesterov (1983) are thus optimal in terms of target precision, smoothness and problem dimension. (in collaboration with Cristóbal Guzmán, Martin Jaggi)

5.2. SAGA: A Fast Incremental Gradient Method With Support for Non-Strongly Convex Composite Objectives

Participants: Simon Lacoste-Julien, Francis Bach.

In this work we introduce a new optimisation method called SAGA in the spirit of SAG, SDCA, MISO and SVRG, a set of recently proposed incremental gradient algorithms with fast linear convergence rates. SAGA improves on the theory behind SAG and SVRG, with better theoretical convergence rates, and has support for composite objectives where a proximal operator is used on the regulariser. Unlike SDCA, SAGA supports non-strongly convex problems directly, and is adaptive to any inherent strong convexity of the problem. Moreover, the proof of the convergence bounds is much simpler than the one of our earlier work SAG. (in collaboration with A. Defazio, ANU)

5.3. Non-parametric Stochastic Approximation with Large Step sizes

Participants: Aymeric Dieuleveut, Francis Bach.

We consider the random-design least-squares regression problem within the reproducing kernel Hilbert space (RKHS) framework. Given a stream of independent and identically distributed input/output data, we aim to learn a regression function within an RKHS \mathcal{H} , even if the optimal predictor (i.e., the conditional expectation) is not in \mathcal{H} . In a stochastic approximation framework where the estimator is updated after each observation, we show that the averaged unregularized least-mean-square algorithm (a form of stochastic gradient), given a sufficient large step-size, attains optimal rates of convergence for a variety of regimes for the smoothnesses of the optimal prediction function and the functions in \mathcal{H} .

5.4. Adaptivity of averaged stochastic gradient descent to local strong convexity for logistic regression

Participant: Francis Bach.

In this work, we consider supervised learning problems such as logistic regression and study the stochastic gradient method with averaging, in the usual stochastic approximation setting where observations are used only once. We show that after N iterations, with a constant step-size proportional to $1/R^2\sqrt{N}$ where N is the number of observations and R is the maximum norm of the observations, the convergence rate is always of order $O(1/\sqrt{N})$, and improves to $O(R^2/\mu N)$ where μ is the lowest eigenvalue of the Hessian at the global optimum (when this eigenvalue is greater than R^2/\sqrt{N}). Since μ does not need to be known in advance, this shows that averaged stochastic gradient is adaptive to *unknown local* strong convexity of the objective function. Our proof relies on the generalized self-concordance properties of the logistic loss and thus extends to all generalized linear models with uniformly bounded features.

5.5. Serialrank: Spectral Ranking using Seriation

Participants: Fajwel Fogel, Alexandre d'Aspremont.

We describe a seriation algorithm for ranking a set of n items given pairwise comparisons between these items. Intuitively, the algorithm assigns similar rankings to items that compare similarly with all others. It does so by constructing a similarity matrix from pairwise comparisons, using seriation methods to reorder this matrix and construct a ranking. We first show that this spectral seriation algorithm recovers the true ranking when all pairwise comparisons are observed and consistent with a total order. We then show that ranking reconstruction is still exact even when some pairwise comparisons are corrupted or missing, and that seriation based spectral ranking is more robust to noise than other scoring methods. An additional benefit of the seriation formulation is that it allows us to solve semi-supervised ranking problems. Experiments on both synthetic and real datasets demonstrate that seriation based spectral ranking achieves competitive and in some cases superior performance compared to classical ranking methods. (in collaboration with Milan Vojnovic, Microsoft Research).

5.6. Sequential Kernel Herding: Frank-Wolfe Optimization for Particle

Filtering

Participants: Simon Lacoste-Julien, Francis Bach.

Recently, the Frank-Wolfe optimization algorithm was suggested as a procedure to obtain adaptive quadrature rules for integrals of functions in a reproducing kernel Hilbert space (RKHS) with a potentially faster rate of convergence than Monte Carlo integration (and "kernel herding" was shown to be a special case of this procedure). In this paper, we propose to replace the random sampling step in a particle filter by Frank-Wolfe optimization. By optimizing the position of the particles, we can obtain better accuracy than random or quasi-Monte Carlo sampling. In applications where the evaluation of the emission probabilities is expensive (such as in robot localization), the additional computational cost to generate the particles through optimization can be justified. Experiments on standard synthetic examples as well as on a robot localization task indicate indeed an improvement of accuracy over random and quasi-Monte Carlo sampling. (in collaboration with Fredrik Lindsten, Cambridge University)

5.7. Learning to Learn for Structured Sparsity

Participants: Nino Shervashidze, Francis Bach.

Structured sparsity has recently emerged in statistics, machine learning and signal processing as a promising paradigm for learning in high-dimensional settings. All existing methods for learning under the assumption of structured sparsity rely on prior knowledge on how to weight (or how to penalize) individual subsets of variables during the subset selection process, which is not available in general. Inferring group weights from data is a key open research problem in structured sparsity.

In this work, we propose a Bayesian approach to the problem of group weight learning. We model the group weights as hyperparameters of heavy-tailed priors on groups of variables and derive an approximate inference scheme to infer these hyperparameters. We empirically show that we are able to recover the model hyperparameters when the data are generated from the model, and we demonstrate the utility of learning weights in synthetic and real denoising problems.

5.8. Analysis of purely random forests bias

Participant: Sylvain Arlot.

Random forests are a very effective and commonly used statistical method, but their full theoretical analysis is still an open problem. As a first step, simplified models such as purely random forests have been introduced, in order to shed light on the good performance of random forests. In this paper, we study the approximation error (the bias) of some purely random forest models in a regression framework, focusing in particular on the influence of the number of trees in the forest. Under some regularity assumptions on the regression function, we show that the bias of an infinite forest decreases at a faster rate (with respect to the size of each tree) than a single tree. As a consequence, infinite forests attain a strictly better risk rate (with respect to the sample size) than single trees. Furthermore, our results allow to derive a minimum number of trees sufficient to reach the same rate as an infinite forest. As a by-product of our analysis, we also show a link between the bias of purely random forests and the bias of some kernel estimators. (In collaboration with Robin Genuer, Université de Bordeaux)

5.9. Large-Margin Metric Learning for Constrained Partitioning Problems

Participants: Rémi Lajugie, Sylvain Arlot, Francis Bach.

We consider unsupervised partitioning problems based explicitly or implicitly on the minimization of Euclidean distortions, such as clustering, image or video segmentation, and other change-point detection problems. We emphasize on cases with specific structure, which include many practical situations ranging from mean-based change-point detection to image segmentation problems. We aim at learning a Mahalanobis metric for these unsupervised problems, leading to feature weighting and/or selection. This is done in a supervised way by assuming the availability of several (partially) labeled datasets that share the same metric. We cast the metric learning problem as a large-margin structured prediction problem, with proper definition of regularizers and losses, leading to a convex optimization problem which can be solved efficiently. Our experiments show how learning the metric can significantly improve performance on bioinformatics, video or image segmentation problems.

5.10. Metric Learning for Aligning temporal sequences

Participants: Damien Garreau, Rémi Lajugie, Sylvain Arlot, Francis Bach.

In this work, we propose to learn a Mahalanobis distance to perform alignment of multivariate time series. The learning examples for this task are time series for which the true alignment is known. We cast the alignment problem as a structured prediction task, and propose realistic losses between alignments for which the optimization is tractable. We provide experiments on real data in the audio to audio context, where we show that the learning of a similarity measure leads to improvements in the performance of the alignment task. We also propose to use this metric learning framework to perform feature selection and, from basic audio features, build a combination of these with better performance for the alignment.

5.11. Weakly Supervised Action Labeling in Videos Under Ordering Constraints

Participants: Rémi Lajugie, Francis Bach.

We are given a set of video clips, each one annotated with an ordered list of actions, such as “walk” then “sit” then “answer phone” extracted from, for example, the associated text script. We seek to temporally localize the individual actions in each clip as well as to learn a discriminative classifier for each action. We formulate the problem as a weakly supervised temporal assignment with ordering constraints. Each video clip is divided into small time intervals and each time interval of each video clip is assigned one action label, while respecting the order in which the action labels appear in the given annotations. We show that the action label assignment can be determined together with learning a classifier for each action in a discriminative manner. We evaluate the proposed model on a new and challenging dataset of 937 video clips with a total of 787720 frames containing sequences of 16 different actions from 69 Hollywood movies. (in collaboration with Piotr Bojanowski, Ivan Laptev, Jean Ponce, Cordelia Schmid and Josef Sivic)

5.12. On Pairwise Cost for Multi-Object Network Flow Tracking

Participant: Simon Lacoste-Julien.

Multi-object tracking has been recently approached with the min-cost network flow optimization techniques. Such methods simultaneously resolve multiple object tracks in a video and enable modeling of dependencies among tracks. Min-cost network flow methods also fit well within the "tracking-by-detection" paradigm where object trajectories are obtained by connecting per-frame outputs of an object detector. Object detectors, however, often fail due to occlusions and clutter in the video. To cope with such situations, we propose an approach that regularizes the tracker by adding second order costs to the min-cost network flow framework. While solving such a problem with integer variables is NP-hard, we present a convex relaxation with an efficient rounding heuristic which empirically gives certificates of small suboptimality. Results are shown on real-world video sequences and demonstrate that the new constraints help selecting longer and more accurate tracks improving over the baseline tracking-by-detection method. (in collaboration with Visesh Chari, Ivan Laptev, Josef Sivic).

5.13. A Markovian approach to distributional semantics with application to semantic compositionality

Participants: Edouard Grave, Francis Bach, Guillaume Obozinski.

In this work, we describe a new approach to distributional semantics. This approach relies on a generative model of sentences with latent variables, which takes the syntax into account by using syntactic dependency trees. Words are then represented as posterior distributions over those latent classes, and the model allows to naturally obtain in-context and out-of-context word representations, which are comparable. We train our model on a large corpus and demonstrate the compositionality capabilities of our approach on different datasets.

5.14. A convex relaxation for weakly supervised relation extraction

Participant: Edouard Grave.

A promising approach to relation extraction, called weak or distant supervision, exploits an existing database of facts as training data, by aligning it to an unlabeled collection of text documents. Using this approach, the task of relation extraction can easily be scaled to hundreds of different relationships. However, distant supervision leads to a challenging multiple instance, multiple label learning problem. Most of the proposed solutions to this problem are based on non-convex formulations, and are thus prone to local minima. In this article, we propose a new approach to the problem of weakly supervised relation extraction, based on discriminative clustering and leading to a convex formulation. We demonstrate that our approach outperforms state-of-the-art methods on a challenging dataset introduced in 2010.

5.15. Weakly supervised named entity classification

Participant: Edouard Grave.

In this paper, we describe a new method for the problem of named entity classification for specialized or technical domains, using distant supervision. Our approach relies on a simple observation: in some specialized domains, named entities are almost unambiguous. Thus, given a seed list of names of entities, it is cheap and easy to obtain positive examples from unlabeled texts using a simple string match. Those positive examples can then be used to train a named entity classifier, by using the PU learning paradigm, which is learning from positive and unlabeled examples. We introduce a new convex formulation to solve this problem, and apply our technique in order to extract named entities from financial reports corresponding to healthcare companies.

5.16. Fast imbalanced binary classification: a moment-based approach

Participant: Edouard Grave.

In this paper, we consider the problem of imbalanced binary classification in which the number of negative examples is much larger than the number of positive examples. The two mainstream methods to deal with such problems are to assign different weights to negative and positive points or to subsample points from the negative class. In this paper, we propose a different approach: we represent the negative class by the two first moments of its probability distribution (the mean and the covariance), while still modeling the positive class by individual examples. Therefore, our formulation does not depend on the number of negative examples, making it suitable to highly imbalanced problems and scalable to large datasets. We demonstrate empirically, on a protein classification task and a text classification task, that our approach achieves similar statistical performance than the two mainstream approaches to imbalanced classification problems, while being more computationally efficient. (in collaboration with Laurent El Ghaoui, U.C. Berkeley)

TAO Project-Team

6. New Results

6.1. Highlights of the Year

- The European commission has chosen Crystal-Supergrids (<http://www.artelys.com/news/120/90/Energy-The-European-Commission-Chooses-Artelys-Crystal>) for energy modeling and planning in Europe. Crystal-Supergrids is based on the Post project, an ADEME project between Artelys and Inria-TAO.
- The HiggsML challenge was the all-time most popular challenge organized by Kaggle. Cécile Germain-Renaud, Balázs Kégl and Marc Schoenauer were part of the organizing committee.
- Creation of the Center for Data Science, an interdisciplinary institute of the Université Paris-Saclay. Co-chaired by Balázs Kégl, with more than 250 permanent researchers in 35 laboratories, the CDS organizes continued cross-fertilization of machine learning and domain sciences.
- Best Paper Award at PPSN .

BEST PAPERS AWARDS :

[36] **13th International Conference on Parallel Problem Solving from Nature**. I. LOSHCHILOV, M. SCHOENAUER, M. SEBAG, N. HANSEN.

6.2. Optimal Decision Making under Uncertainty

Participants: Olivier Teytaud [correspondent], Jean-Joseph Christophe, Jérémie Decock, Nicolas Galichet, Marc Schoenauer, Michèle Sebag, Weijia Wang.

The UCT-SIG works on sequential optimization problems, where a decision has to be made at each time step along a finite time horizon, and the underlying problem involves uncertainties along an either adversarial or stochastic setting.

After several years of success in the domain of GO, the most prominent application domain here is now energy management, at various time scales, and more generally planning. Furthermore, the work in this SIG has also lead to advances in continuous optimization at large, that somehow overlap with the work in the OPT-SIG (see 6.3).

The main advances done this year include:

Bandit-based Algorithms Active learning for the identification of biological dynamical systems has been tackled using Multi-Armed Bandit algorithms [35]. Weijia Wang's PhD [5] somehow summarizes the work done in TAO regarding Multi-objective Reinforcement Learning with MCTS algorithm. Differential Evolution was applied as an alternative to solve non-stationary Bandit problems [45].

Continuous optimization: parallelism, real-world, high-dimension and cutting-plane methods

Our work in continuous optimization extends testbeds as follows: (i) including higher dimension (many testbeds in evolutionary algorithms consider dimension ≤ 40 or ≤ 100) (ii) taking into account computation time and not only the number of function evaluations (this makes a big difference in high dimension) (iii) including real world objective functions (iv) including parallelism, in particular, parallel convergence rates for differential evolution and particle swarm optimization [21]. We have a parallel version of cutting plane methods, which use more than black-box evaluations of the objective functions - we keep in mind that some of our black-box methods, on the other hand, also do not need convexity or the existence of a gradient.

Noisy optimization We have been working on noisy optimization in discrete and continuous domains.

In the discrete case, we have shown the impact of heavy tails, and we have shown that resampling can solve some published open problems in an anytime manner. In the continuous case, we have shown [16] that a classical evolutionary principle (namely the step-size proportional to the distance to the optimum) implies that the optimal rates can not be reached - more precisely, we can have simple regret at best $O(1/\sqrt{\text{number of fitness evaluations}})$ in the simple case of an additive noise, whereas some published algorithms reached $O(1/\text{number of fitness evaluations})$. One of the most directly applicable of our works is bias correction when the objective function $f(x)$ has the form $f(x) = \mathbb{E}_\omega f(x, \omega)$ and is approximated by $f(x) = \frac{1}{N} \sum_{i=1}^N f(x, \omega_i)$ for a given finite sample $\omega_1, \dots, \omega_N$. We have also worked on portfolios of noisy optimizers [20], [34].

Discrete-time control with constrained action spaces. While Direct Policy Search is a reliable approach for discrete time control, it is not easily applicable in the case of a constrained high-dimensional action space. In the past, we have proposed DVS (Direct Value Search) for such cases [54]. The method is satisfactory, and we have additional mathematical results; in particular we prove positive results for non-Markovian, non-convex problems, and we prove a polynomial-time decision making and, simultaneously, exact asymptotic consistency for a non-linear transition [24]. Related work [60] also proposes to directly learn the value function, in a RL context, using some trajectories known to be bad.

Games. While still lightly contributing to the game of GO with our taiwanese partners [8], we obtained significant improvements in randomized artificial intelligence algorithms by decomposing the variance of the result into (i) the random seed (ii) the other random contributions such as the random seed of the opponent and/or the random part in the game. By optimizing our probability distribution on random seeds, we get significant improvements in e.g. phantom Go. This is basically a simple tool for learning opening books [44].

Adversarial bandits. High-dimensional adversarial bandits lead to two main drawbacks: (i) computation time (ii) highly mixed nature of the obtained solution. We developed methods which focus on sparse solution. Provably consistent, these methods are faster when the Nash equilibrium is sparse, and provides highly sparse solutions[17].

6.3. Continuous Optimization

Participants: Ouassim Ait Elhara, Asma Atamna, Anne Auger, Alexandre Chotard, Nikolaus Hansen, Yann Ollivier, Marc Schoenauer, Michèle Sebag, Olivier Teytaud, Luigi Malago, Emmanuel Benazera.

Our main expertise in continuous optimization is on stochastic search algorithms. We address theory, algorithm design, and applications. The methods we investigate are adaptive techniques able to learn iteratively parameters of the distribution used to sample solutions. The Covariance Matrix Adaptation Evolution Strategy (CMA-ES) is nowadays one of the most powerful methods for derivative-free continuous optimization. We work on different variants of the CMA-ES to improve it in various contexts as described below. We are well recognized in the field and were invited to write a book chapter on the design of continuous stochastic search[50].

Online adaptation of CMA-ES hyperparameters CMA-ES uses clever mechanisms to adapt the covariance matrix and the step-size, based on the evolution path. However, these mechanisms in turn use learning parameters, that were adjusted by trial-and-error in the seminal algorithm. However, thanks to the invariance properties of the algorithm, these values have been demonstrated to be very robust. An original mechanism has been proposed to adapt these hyper-parameters online, maximizing the likelihood of the selected sample at time to adapt the hyperparameters at time $t-1$. The corresponding paper published at PPSN received the Best Paper Award [36].

Linear Time and Space Complexity CMA-ES for Large-Scale Optimization We have been proposing a large-scale version of CMA-ES where the covariance matrix is restricted to a linear numbers of parameters. The update for the covariance matrix has been derived using the Information

Geometric Optimization (IGO) framework and cumulation concepts borrowed from the original CMA have been additionally included [14]. This work is part of a joint project between the TAO team and Shinshu university in Japan funded by the Japanese government. In this context, Luigi Malago is visiting the team working on extending the proposed algorithm to a richer model.

Evaluation of Black-Box Optimizers We have been focusing on appraising the performance of step-size adaptation mechanisms for stochastic adaptive algorithms. We have shown that a too restrictive choice of test functions for the design of a method leads to misleading conclusions and proposed a thorough framework for evaluating step-size mechanism [29]. We have been pursuing our effort for *thorough and rigorous* benchmarking of black-box algorithms by organizing two more Black-Box-Optimization Benchmarking workshops that will take place at CEC 2015 and GECCO 2015. Those workshops are based on the platform COCO that we develop in the context of the ANR NumBBO project.

Theoretical Analysis of Stochastic Adaptive Algorithms We have analyzed the CSA-ES algorithm using resampling for **constrained optimization** on a linear function with a linear constraint. We have studied the behavior of the algorithm and proven success of failure of the algorithm depending on internal parameters of the algorithm [22]. We have extended a previous work on a linear function from the use of standard normal distribution to more general ones [23]. The published paper has been invited for an extension in an ECJ special issue. The extended paper had been submitted in december 2014. We have been providing a general methodology to prove the linear convergence of Comparison-based Step-size Adaptive Randomized Search on scaling-invariant functions by analyzing the stability of underlying Markov chains [57].

CMA-ES Library Besides our continuous work on implementations of CMA-ES (see e.g. [github](#), [PyPI](#)), we have created a new library in C++11 ([libcmaes](#)). As part of the ANR SIMINOLE project, the library has been coupled with [ROOT](#), the data analysis framework used at CERN, and generally in physics.

6.4. Applications to E-science

Participants: Cécile Germain-Renaud [correspondent], Marco Bressan, Philippe Caillou, Dawei Feng, Cyril Furtlehner, Blaise Hanczar, Karima Rafes, Balázs Kégl, Michèle Sebag.

The E-S-SIG explores the issues related to applications to E-Science, starting with modeling and optimizing very large scale computational grids, in particular in the context of Physics, to social sciences modelling with multi-agent systems.

The Higgs boson Machine Learning challenge The HiggsML challenge⁰ has been set up to promote collaboration between high-energy physicists and computer scientists. The challenge, hosted by Kaggle, has drawn a remarkably large audience (with 1700+ teams it is one of the all-time most popular Kaggle challenges) and large coverage both in the social networks and in the media.

The goal of the challenge is to improve the procedure that classifies events produced by the decay of the Higgs boson versus events produced by other (background) processes, based on a training set of 250,000 examples. The challenge is a premier: it is the first time that a CERN experiment (ATLAS) made public such a large set of the official event and detector simulations. It also features a unique formal objective representing an approximation of the median significance (AMS) of a discovery (counting) test, which generates interesting algorithmic/theoretical questions beyond the usual challenges of finding and tuning the best classification algorithm [55].

A follow-up, the HEPML workshop was organized at NIPS14⁰, reporting on the results and the winning algorithms. The dataset and a software toolkit are available from the CERN Data Portal⁰

⁰<https://www.kaggle.com/c/higgs-boson>

⁰<http://nips.cc/Conferences/2014/Program/event.php?ID=4292>

⁰<http://opendata.cern.ch>

The Center for Data Science is a Lidex of the Université Paris-Saclay (UPSay), headed by Balazs Kégl and Arnak Dalalyan, gathering over 52 research teams and 34 labs with the goal of designing and applying automated methods to analyze massive and complex scientific datasets in order to extract useful information. Data science projects require expertise from a vast spectrum of disciplines (statistics, signal processing, machine learning, data mining, data visualization, high performance computing), besides the mastery of the scientific domain where the data originate from.

The goal of CDS is to establish an institutionalized agora in which scientists can find each other, exchange ideas, initiate and nurture interdisciplinary projects, and share their experience on past data science projects. To foster synergy between data analysts and data producers CDS organizes actions to provide initial resources for helping collaborations to get off the ground, to mitigate the non-negligible risk taken by researchers venturing into interdisciplinary data science projects, and to encourage the use of unconventional forms of information transmission and dissemination essential in this communication-intensive research area. The CDS fits perfectly in the recent surge of similar initiatives, both at the international and at the national level, and it has the potential to make the University Paris-Saclay one of the international fore-runners of data science ⁰.

Fault management As Lamport formulated decades ago, fault management in distributed systems exemplifies the unreachability of exact prior knowledge. Real-world large scale system add a supplementary complexity, which is non-stationarity.

- [12] models the system state and its ruptures (non-stationarity) through the flow of jobs as a stream (scalability), with a traceability goal (interpretability). These new streaming approaches involve self-calibration of the model based on scale invariance.
- D. Feng’s PhD thesis [3] formulates the problem of probe selection for fault prediction based on end-to-end probing as a Collaborative Prediction (CP) problem, based on the reasonable assumption of an underlying factorial model. [26] extends the matrix completion/compressed sensing setup to a sequential (tensor) context. We propose and evaluate a new algorithm, *Sequential Matrix Factorization* (SMF) that combines matrix completion with a self-calibrating exploration/exploitation balancing heuristic. Its active learning version (SMFA) exhibits superior performance over state-of-the-art methods.

Distributed system observation The work on distributed system automated analysis and description [7] has been pursued thru the continued development of the GAMA multi-agent framework <https://code.google.com/p/gama-platform/wiki/GAMA>. Philipps Caillou is associated to the new young researcher ANR ACTEUR, coordinated by Patrick Taillandier (IDEES, Rouen university), which will give an additional structure for further collaborations.

Identifying leaders in Social Networks The Modyrum contract with the SME Augure (funding Marco Bressan’s Post-doc) aims at providing criteria to identify the trend leaders from blogs, tweets and other web-site posts. The same methods is being applied to fashion leaders in business as well as to opinion leaders in politics.

6.5. Designing criteria

Participants: Jamal Atif, Aurélien Decelle, Cyril Furtlehner, Yoann Isaac, Alexandre Quemy, Yann Ollivier, Marc Schoenauer, Michèle Sebag.

This SIG, rooted on the claim that *What matters is the criterion*, aims at defining new learning or optimization objectives reflecting fundamental properties of the model, the problem or the expert prior knowledge.

A statistical physics perspective With motivating applications in large scale inference problems like traffic congestions we are pursuing our quest of practical solutions to inverse problems like in [39] where a method is proposed to invert a Gaussian Markov random field with topological and spectral constraints well suited to subsequent use of belief propagation as inference algorithm

⁰<http://www.datascience-paris-saclay.fr/en>

(see <https://who.rocq.inria.fr/Jean-Marc.Lasgouttes/star-ips> for the implementation). A more specific model for traffic inference has also been developed in [11]. A method adapted to the generalized belief propagation framework, aiming at addressing directly and systematically the loop corrections without loss of scalability is about to be completed.

Multi-objective ATC The new Bayesian approach of Air Traffic Control belongs to this SIG, but was described in the Section 4.2. Main publications are Gaétan Marceau's PhD [4] and the corresponding PPSN paper [38], [59].

Programming by Feedback Riad Akrouf's PhD work on Preference Based Learning [1] culminated with the addition of a model for the user's competence in the interactive learning loop. In the resulting original paradigm, the user is sequentially proposed a series of behaviors and is only asked "Hot-or-cold" questions. The *Programming by Feedback* paradigm [15] will hopefully initiate a general way to allow non-digitally-proficient users to nevertheless control the behavior of software-based agents in their environment.

Multi-objective AI Planning This activity had almost stopped since the end of the DESCARWIN ANR project. However, a productive internship resulted in some new benchmarks in the ZenoTravel domain together with an exact solver ensuring the knowledge of the true Pareto front [41], [40].

Algorithm Selection Algorithm Selection can be viewed as a Collaborative Filtering problem, in which a problem "likes" an algorithm that is able to solve it. Initiated during Mustafa Misir's ERCIM postdoc in 2013, this idea has also been applied for Process Management [43], and is the basis of François Gonards's PhD funded by IRT SystemX in the context of aeronautics and car industry.

Outlier rejection in classification An original approach based on One-Class SVM has been proposed during Blaise Hanczar's on year *delegation* at TAO [28].

Learning sparse representations by auto-encoders Auto-encoders (AE) are a widely used tool for unsupervised learning, which consists of a neural network trained to reconstruct its own input via smaller-dimensional layers. The usual training criterion is the reconstruction error, however, the usual justification for AE is to learn a more compact data representation. In [62] we formalize this latter criterion using Minimum Description Length (MDL) and establish a comparison with the traditional reconstruction criterion. The MDL criterion has an interpretation as a denoising reconstruction and fully determines an optimal noise level, contrary to the literature on denoising AEs. More surprisingly, AE (aka Auto-associators) can also be used to learn sparse representations in the context of supervised learning [51].

ASPI Project-Team

5. New Results

5.1. Adaptive multilevel splitting

Participants: Frédéric C  rou, Arnaud Guyader.

We show [21] that an adaptive version of multilevel splitting for rare events is strongly consistent. We also show that the estimates satisfy a CLT (central limit theorem), with the same asymptotic variance as the non-adaptive algorithm with the optimal choice of the parameters. It is a strong and general result, that generalizes some of our previous results, and the proof is quite technical and involved.

This work has been presented at the 10th International Workshop on Rare Event Simulation (RESIM), held in Amsterdam in August 2014.

5.2. Convergence of a two-step multilevel splitting algorithm for rare event simulation

Participants: Fran  ois Le Gland, Damien-Barth  l  my Jacquemart.

The problem is to accurately estimate the (very small) probability that a rare but critical event (such as a score function exceeding a given threshold) occurs before some fixed final time. Multilevel splitting is a very efficient solution, in which sample paths are propagated and are eliminated or replicated when some intermediate events (defined by some intermediate thresholds) occur. A common and efficient design is to define the next intermediate level as an empirical quantile of the running maximum of the score function along a surviving trajectory. However, it is practically impossible to remember when (at which time instant) and where (in which state) did each successful trajectory cross the empirically defined threshold. The proposed design is a two-step adaptive multilevel splitting algorithm: In the first step, a first set of trajectories is sampled in order to obtain the next intermediate threshold as an empirical quantile. In the second step, once the new intermediate threshold is obtained, a second set of trajectories is sampled in order to evaluate the transition probability to the new empirically defined intermediate region. This two-step procedure is repeated until some trajectories do hit the critical region before final time.

This work has been presented at the 10th International Workshop on Rare Event Simulation (RESIM), held in Amsterdam in August 2014.

5.3. Simulation-based algorithms for the optimization of sensor deployment

Participant: Fran  ois Le Gland.

This is a collaboration with Christian Musso (ONERA, Palaiseau) and with S  bastien Paris (LSIS, universit   du Sud Toulon Var), related with the supervision of the PhD thesis of Yannick Kenn  .

The problem considered here can be described as follows: a limited number of sensors should be deployed by a carrier in a given area, and should be activated at a limited number of time instants within a given time period, so as to maximize the probability of detecting a target (present in the given area during the given time period). There is an information dissymmetry in the problem: if the target is sufficiently close to a sensor position when it is activated, then the target can learn about the presence and exact position of the sensor, and can temporarily modify its trajectory so as to escape away before it is detected. This is referred to as the target intelligence. Two different simulation-based algorithms have been designed to solve separately or jointly this optimization problem, with different and complementary features. One is fast, and sequential: it proceeds by running a population of targets and by dropping and activating a new sensor (or re-activating a sensor already available) where and when this action seems appropriate. The other is slow, iterative, and non-sequential; it proceeds by updating a population of deployment plans with guaranteed and increasing criterion value at each

iteration, and for each given deployment plan, there is a population of targets running to evaluate the criterion. Finally, the two algorithms can cooperate in many different ways, to try and get the best of both approaches. A simple and efficient way is to use the deployment plans provided by the sequential algorithm as the initial population for the iterative algorithm.

This work has been presented at the Conference on Optimization and Practices in Industry (COPI), held in Palaiseau in October 2014.

5.4. Non-homogeneous Markov switching auto-regressive models for wind time series

Participants: Valérie Monbet, Julie Bessac.

This is a collaboration with Pierre Ailliot (UBO) and Françoise Pène (UBO).

We proposed [20] non-homogeneous Markov switching auto-regressive models for bivariate wind time series considering Cartesian coordinates on one hand and polar coordinates on the other hand. In non-homogeneous models, the transitions depend on the wind direction at the previous time. At the location of interest, wind is rotating more often clockwise but wind direction may also oscillate around two prevailing directions (northeast for anti-cyclonic conditions and southwest for cyclonic conditions). These features induce respectively some cycles which can be seen in the second order structure and modes in the marginal distribution. In broad outline, non-homogeneous transitions help the process to stay in the same weather regime when the wind direction is close to the prevailing directions and lead to sojourn duration in the regimes which are not geometric.

5.5. Gaussian state-space models for wind speed

Participants: Valérie Monbet, Julie Bessac.

This is a collaboration with Pierre Ailliot (UBO).

A multi-site stochastic generator for wind speed has been developed [11]. It aims at simulating realistic wind conditions with a focus on reproducing the space-time motions of the meteorological systems. A Gaussian linear state-space model is used where the latent state may be interpreted as regional wind conditions and the observation equation links regional and local scales. The model is fitted to 6-hourly reanalysis data in the North-East Atlantic. It is shown that it is interpretable and provides a good description of important properties of the space-time covariance function of the data, such as the non full-symmetry induced by prevailing flows in this area.

5.6. Level-dependent time deformation of Gaussian processes

Participant: Valérie Monbet.

Many records in environmental science exhibit asymmetries. In this project, we introduce a time deformation to produce asymmetric path from a Gaussian process with symmetric path. A simple case is obtained by assuming that

$$Z_t = Y_{\phi(t)}, \quad \phi(t) = \int_0^t f(Z_s) ds$$

with $\{Y_t\}$ a stationary Gaussian process. The function f which controls the time deformation is increasing. The time-change function ϕ is such that the modified time increases quicker when the process is at high levels and thus that the crests of the modified process $\{Z_t\}$ are narrower than the ones of $\{Y_t\}$. The opposite holds true for the troughs. Inference tools are developed to estimate the function f .

5.7. Self-similar prior and wavelet bases for hidden turbulent motion

Participant: Patrick Héas.

This is a collaboration with Frédéric Lavancier (université de Nantes) and Souleymane Kadri-Harouna (université de la Rochelle)

This work [14] is concerned with the ill-posed inverse problem of estimating turbulent flows from the observation of an image sequence. From a Bayesian perspective, a divergence-free isotropic fractional Brownian motion (fBm) is chosen as a prior model for instantaneous turbulent velocity fields. This self-similar prior characterizes accurately second-order statistics of velocity fields in incompressible isotropic turbulence. Nevertheless, the associated maximum a posteriori involves a fractional Laplacian operator which is delicate to implement in practice. To deal with this issue, we propose to decompose the divergence-free fBm on well-chosen wavelet bases. As a first alternative, we propose to design wavelets as whitening filters. We show that these filters are fractional Laplacian wavelets composed with the Leray projector. As a second alternative, we use a divergence-free wavelet basis, which takes implicitly into account the incompressibility constraint arising from physics. Although the latter decomposition involves correlated wavelet coefficients, we are able to handle this dependence in practice. Based on these two wavelet decompositions, we finally provide effective and efficient algorithms to approach the maximum a posteriori.

5.8. Estimation of non-linear dynamics under sparse constraints

Participant: Patrick Héas.

This is a collaboration with Cédéric Herzet (EPI FLUMINANCE, Inria Rennes-Bretagne Atlantique) and Angélique Drémeau (ENSTA Bretagne, Brest).

Following recent contributions in non-linear sparse representations, this work [19], [18] focuses on a particular non-linear model, defined as the nested composition of functions. This family includes in particular discrete-time hidden Markov models. Recalling that most linear sparse representation algorithms can be straightforwardly extended to non-linear models, we emphasize that their performance highly relies on an efficient computation of the gradient of the objective function. In the particular case of interest, we propose to resort to a well-known technique from the theory of optimal control to evaluate the gradient. This computation is then implemented into the ℓ_1 -reweighted procedure proposed by Candès et al. [24], leading to a non-linear extension of it. As an example, we consider the problem of estimating the ocean state from satellite low-dimensional information by exploiting a geophysical dynamical model and a sparse decomposition of the initial condition in some redundant dictionary.

This work has also been presented at Congrès National d'Assimilation, a national event held in Toulouse in December 2014.

CQFD Project-Team

6. New Results

6.1. Highlights of the Year

Creation of the Associate Team Inria: CDSS (2014-2016) with the University of Sao Paulo, Brasil.

6.2. Approximate Kalman–Bucy filter for continuous-time semi-Markov jump linear systems

Participants: Benoîte de Saporta, Eduardo Costa.

We propose a new numerical approximation of the Kalman–Bucy filter for semi-Markov jump linear systems. This approximation is based on the selection of typical trajectories of the driving semi-Markov chain of the process by using an optimal quantization technique. The main advantage of this approach is that it makes pre-computations possible. We derive a Lipschitz property for the solution of the Riccati equation and a general result on the convergence of perturbed solutions of semi-Markov switching Riccati equations when the perturbation comes from the driving semi-Markov chain. Based on these results, we prove the convergence of our approximation scheme in a general infinite countable state space framework and derive an error bound in terms of the quantization error and time discretization step. We employ the proposed filter in a magnetic levitation example with markovian failures and compare its performance with both the Kalman–Bucy filter and the Markovian linear minimum mean squares estimator. This work was presented at the international conference [37] and is submitted to an international journal [50].

6.3. Modeling and optimization of a launcher integration process

Participants: Benoîte de Saporta, François Dufour, Christophe Nivot.

We are interested in the optimization of a launcher integration process. It comprises several steps from the production of the subassemblies to the final launch. The four subassemblies go through various types of operations such as preparation, integration, control and storage. These operations are split up into three workshops. Due to possible breakdowns or staff issues, the time spent in each workshop is supposed random. So is the time needed to deliver the subassemblies, for similar reasons including e.g. shipping delays. We also have to deal with constraints related to the architecture of the assembly process itself. Indeed, we have to take into account waiting policies between workshops. The workshops may work in parallel but can be blocked if their output is not transferred to the next workshop in line. Storage capacity of output products is limited.

Our goal is finding the best rates of delivery of the subassemblies, the best choice of architecture (regarding stock capacities) and the best times when to stop and restart the workshops to be able to carry out twelve launches a year according to a predetermined schedule at minimal cost. To solve this problem, we choose a mathematical model particularly suitable for optimization with randomness: Markov decision processes (MDPs).

We have implemented a numerical simulator of the process based on the MDP model. It provides the fullest information possible on the process at any time. The simulator has first been validated with deterministic histories. Random histories have then been run with exponentially distributed delivery times for the subassemblies and several families of random laws for the time spent in each workshop. Using Monte Carlo simulations, we obtain the distribution of the launch times. Preliminary optimization results allow choosing stock capacities and delivery rates that satisfy the launch schedule. Work is still in progress concerning cost minimization. It was presented at Airbus internal PhD seminar in November 2014.

6.4. Numerical approximation for optimal stopping of MDP under partial observation

Participants: Benoîte de Saporta, François Dufour, Christophe Nivot.

We consider the optimal stopping problem for a continuous finite-dimensional state space Markov chain under partial observation. Our aim is to build a numerical approximation of the value function. To do so, we first translate the problem into the Partially Observed Markov Decision Process (POMDP) framework. Then, we define the equivalent fully observed Markov Decision Process (MDP) on an infinite dimensional state space. Finally, we proposed a discretization scheme based on the discretization of an underlying measure to obtain a finite dimensional problem and a discretization of the resulting state space to obtain a fully discrete model that is numerically tractable. We prove the convergence of the approximation procedure. This work is still in progress and was presented at the workshop [31]

6.5. Classification of EEG signals by evolutionary algorithm

Participants: Marie Chavent, Pierrick Legrand, Leonardo Trujillo.

The goal of this work is to predict the state of alertness of an individual by analyzing the brain activity through electroencephalographic data (EEG) captured with 58 electrodes. Alertness is characterized here as a binary variable that can be in a "normal" or "relaxed" state. We collected data from 44 subjects before and after a relaxation practice, giving a total of 88 records. After a pre-processing step and data validation, we analyzed each record and discriminate the alertness states using our proposed "slope criterion". Afterwards, several common methods for supervised classification (k nearest neighbors, decision trees (CART), random forests, PLS and discriminant sparse PLS) were applied as predictors for the state of alertness of each subject. The proposed "slope criterion" was further refined using a genetic algorithm to select the most important EEG electrodes in terms of classification accuracy. Results show that the proposed strategy derives accurate predictive models of alertness.

This work has been published in a book chapter [45].

6.6. Probabilistic low-rank matrix completion with adaptive spectral regularization algorithms

Participants: Marie Chavent, Adrien Todeschini.

We propose a novel class of algorithms for low rank matrix completion. Our approach builds on novel penalty functions on the singular values of the low rank matrix. By exploiting a mixture model representation of this penalty, we show that a suitably chosen set of latent variables enables to derive an EM algorithm to obtain a Maximum A Posteriori estimate of the completed low rank matrix. The resulting algorithm is an iterative soft-thresholded algorithm which iteratively adapts the shrinkage coefficients associated to the singular values.

This work is in collaboration with Francois Caron from University of Oxford. It has been presented in the national conference of the French Statistical Society of Statistics [41]

6.7. Variable selection to construct indicators of quality of life for data structured in groups

Participants: Marie Chavent, Amaury Labenne, Jérôme Saracco.

The analysis and measurement of quality of life may be made via two complementary approaches. The first one, based on survey of individuals, concerns the analysis of levels of life satisfaction. We focus here on the second one, based on national data, which analyses living conditions of people. The aim is to create composite indices of living conditions. According to authors, the components of quality of life are related to different themes (groups of variables): "Family conditions", "Employment", "Housing",... For this purpose, dimension reduction methods are particularly suitable. Multiple Factor Analysis (MFA) is a method designed to handle data structured into groups of quantitative variables. In our study, each theme is composed of a group of quantitative and/or categorical variables. Since our data are naturally structured in groups of variables, we develop an extension of MFA for mixed data type, called MFAmix. Thus the principal components from MFAmix are our composite indices for measuring quality of life. However, the creation of these indices raises two questions. How many principal components keep to create indices? How select a limited number of variables to get similar indices for easier interpretation? We propose answers to these questions in this communication.

This work is in collaboration with Vanessa Kuentz from Irstea. It has been presented in the french meeting of the R users (Rencontres R) [40] and in the international conference COMPSTAT 2014 [36].

6.8. Efficiency of simulation in monotone hyper-stable queueing networks

Participants: Jonatha Anselmi, Bruno Gaujal.

We consider Jackson queueing networks with finite buffer constraints (JQN) and analyze the efficiency of sampling from their stationary distribution. In the context of exact sampling, the monotonicity structure of JQNs ensures that such efficiency is of the order of the 'coupling time' (or meeting time) of two extremal sample paths. In the context of approximate sampling, it is given by the 'mixing time'. Under a condition on the drift of the stochastic process underlying a JQN, which we call hyper-stability, in our main result we show that the coupling time is polynomial in both the number of queues and buffer sizes. Then, we use this result to show that the mixing time of JQNs behaves similarly up to a given precision threshold. Our proof relies on a recursive formula relating the coupling times of trajectories that start from network states having 'distance one', and it can be used to analyze the coupling and mixing times of other Markovian networks, provided that they are monotone. An illustrative example is shown in the context of JQNs with blocking mechanisms. This work has been published in an international journal; see [11].

6.9. Control of parallel non-observable queues: asymptotic equivalence and optimality of periodic policies

Participants: Jonatha Anselmi, Bruno Gaujal, Tommaso Nesti.

We consider a queueing system composed of a dispatcher that routes deterministically jobs to a set of non-observable queues working in parallel. In this setting, the fundamental problem is which policy should the dispatcher implement to minimize the stationary mean waiting time of the incoming jobs. We present a structural property that holds in the classic scaling of the system where the network demand (arrival rate of jobs) grows proportionally with the number of queues. Assume that each queue of type r is replicated k times and consider the set of policies that are periodic with period $k \sum_r p_r$ and such that exactly p_r jobs are sent in a period to each queue of type r . When $k \rightarrow \infty$, our main result shows that all the policies in this set are equivalent, in the sense that they yield the same mean stationary waiting time, and optimal, in the sense that no other policy having the same aggregate arrival rate to all queues of a given type can do better in minimizing the stationary mean waiting time. This property holds in a strong probabilistic sense. Furthermore, the limiting mean waiting time achieved by our policies is a convex function of the arrival rate in each queue, which facilitates the development of a further optimization aimed at solving the fundamental problem above for large systems. This work has been accepted for publication in the international journal "Stochastic Systems", the flagship journal of the INFORMS Applied Probability Society; see [46].

6.10. The economics of the cloud: price competition and congestion

Participants: Jonatha Anselmi, Danilo Ardagna, Jonh C.s. Lui, Adam Wierman, Yunjian Xu, Zichao Yang.

This work proposes a model to study the interaction of price competition and congestion in the cloud computing marketplace. Specifically, we propose a three-tier market model that captures a marketplace with users purchasing services from Software-as-a-Service (SaaS) providers, which in turn purchase computing resources from either Provider-as-a-Service (PaaS) providers or Infrastructure-as-a-Service (IaaS) providers. Within each level, we define and characterize competitive equilibria. Further, we use these characterizations to understand the relative profitability of SaaSs and PaaS/IaaSs, and to understand the impact of price competition on the user experienced performance, i.e., the ‘price of anarchy’ of the cloud marketplace. Our results highlight that both of these depend fundamentally on the degree to which congestion results from shared or dedicated resources in the cloud. This work has been submitted to an international journal. A preliminary has been published in [10].

6.11. Generalized Nash Equilibria for Platform-as-a-Service Clouds

Participants: Jonatha Anselmi, Danilo Ardagna, Mauro Passacantando.

Cloud computing is an emerging technology that allows to access computing resources on a pay-per-use basis. The main challenges in this area are the client performance management and the energy costs minimization. In this work we model the service provisioning problem of Cloud Platform-as-a-Service systems as a Generalized Nash Equilibrium Problem and show that a potential function for the game exists. Moreover, we prove that the social optimum problem is convex and we derive some properties of social optima from the corresponding Karush-Kuhn-Tucker system. Next, we propose a distributed solution algorithm based on the best response dynamics and we prove its convergence to generalized Nash equilibria. Finally, we numerically evaluate equilibria in terms of their efficiency with respect to the social optimum of the Cloud by varying our algorithm initial solution. Numerical results show that our algorithm is scalable and very efficient and thus can be adopted for the run-time management of very large scale systems. This work has been published in an international journal; see [12].

6.12. Stochastic approximations of constrained discounted Markov decision processes

Participants: Francois Dufour, Tomas Prieto-Rumeau.

We consider a discrete-time constrained Markov decision process under the discounted cost optimality criterion. The state and action spaces are assumed to be Borel spaces, while the cost and constraint functions might be unbounded. We are interested in approximating numerically the optimal discounted constrained cost. To this end, we suppose that the transition kernel of the Markov decision process is absolutely continuous with respect to some probability measure μ . Then, by solving the linear programming formulation of a constrained control problem related to the empirical probability measure μ_n of μ , we obtain the corresponding approximation of the optimal constrained cost. We derive a concentration inequality which gives bounds on the probability that the estimation error is larger than some given constant. This bound is shown to decrease exponentially in n . Our theoretical results are illustrated with a numerical application based on a stochastic version of the Beverton-Holt population model. This work has been published in Journal of Mathematical Analysis and applications: [27].

6.13. Non-Parametric Estimation of the Conditional Distribution of the Interjumping Times for Piecewise-Deterministic Markov Processes

Participants: Romain Azais, Francois Dufour, Anne Gegout-Petit.

We study a nonparametric method for estimating the conditional density associated to the jump rate of a piecewise-deterministic Markov process. In our framework, the estimation needs only one observation of the process within a long time interval. Our method relies on a generalization of Aalen’s multiplicative intensity model. We prove the uniform consistency of our estimator, under some reasonable assumptions related to the primitive characteristics of the process. A simulation study illustrates the behavior of our estimator. This work has been published in Scandinavian Journal of Statistics: [15].

6.14. Approximation of average cost Markov decision processes using empirical distributions and concentration inequalities

Participants: Francois Dufour, Tomas Prieto-Rumeau.

We consider a discrete-time Markov decision process with Borel state and action spaces, and possibly unbounded cost function. We assume that the Markov transition kernel is absolutely continuous with respect to some probability measure μ . By replacing this probability measure with its empirical distribution μ_n for a sample of size n , we obtain a finite state space control problem, which is used to provide an approximation of the optimal value and an optimal policy of the original control model. We impose Lipschitz continuity properties on the control model and its associated density functions. We measure the accuracy of the approximation of the optimal value and an optimal policy by means of a non-asymptotic concentration inequality based on the 1-Wasserstein distance between μ and μ_n . Obtaining numerically the solution of the approximating control model is discussed and an application to an inventory management problem is presented. This work has been published in *Stochastics An International Journal of Probability and Stochastic Processes*: [26].

6.15. Piecewise Deterministic Markov Processes based approach applied to an offshore oil production system

Participants: Huilong Zhang, Fares Innal, François Dufour, Yves Dutuit.

This work is keeping with the topic of two papers which treated dynamic reliability problems and were presented in previous conferences. Its aim is to confirm the potentialities of a method which combines the high modeling ability of the piecewise deterministic processes and the great computing power inherent to the Monte Carlo simulation. This method is now applied to a simplified but realistic offshore oil production system which is a hybrid system combining continuous-time and discrete-time dynamics. The results thus obtained have been compared with those given by an ad hoc Petri net model for comparison and validation purposes. This work has been published in an international journal; see [29].

6.16. Optimal Trajectories for Underwater Vehicles by Quantization and Stochastic control

Participants: Huilong Zhang, Benoîte de Saporta, François Dufour, Dann Laneuville, Adrien Nègre.

We propose in this paper a numerical method which computes the trajectory of a vehicle subject to some mission objectives. The method is applied to a submarine whose goal is to best detect one or several targets (we consider signal attenuation due to acoustic propagation) or/and to minimize its own detection range perceived by the other targets. Our approach is based on dynamic programming of a finite horizon Markov decision process. The position and the velocity of the targets are supposed to be known only up to a random estimation error, as a Kalman type filter is used to estimate these quantities from the measurements given by the on board sonar. We also take into account the information on the environment through a sound propagation code. A quantization method is applied to fully discretize the problem and solve it numerically. This work is still in progress and was presented at the international conference [39].

6.17. Multi-Objective Design and Maintenance Optimization of the Heated Hold-Up Tank Modeled by Piecewise Deterministic Markov Processes

Participants: Huilong Zhang, Yanfu Li.

We propose a numerical method for the optimal design and maintenance for the heated hold-up tank system. A multi-objective problem is framed to consider simultaneously the objectives of maximizing the operation profit and maximizing the reliability. The system consists of a tank containing a fluid whose level is controlled by three components: two inlet pumps and one outlet valve. A thermal power source heats up the fluid. The failure rates of the components depend on the temperature, the position of the three components monitors the liquid level in the tank and the liquid level determines the temperature. We model the system by a piecewise deterministic Markov process. To find the solution of the optimal maintenance interval, the non-dominated sorting genetic algorithm-II (NSGA-II) is used. This work is still in progress and was presented at the international conference [42].

6.18. Conditional quantile estimation through optimal quantization

Participants: Isabelle Charlier, Jérôme Saracco.

We use quantization to construct a nonparametric estimator of conditional quantiles of a scalar response Y given a d -dimensional vector of covariates X . First we focus on the population level and show how optimal quantization of X , which consists in discretizing X by projecting it on an appropriate grid of N points, allows to approximate conditional quantiles of Y given X . We show that this approximation is arbitrarily good as N goes to infinity and provide a rate of convergence for the approximation error. Then we turn to the sample case and define an estimator of conditional quantiles based on quantization ideas. We prove that this estimator is consistent for its fixed- N population counterpart. The results are illustrated on a numerical example. This work is in collaboration with Davy Paindaveine from Université Libre de Bruxelles. It has been presented in the national conference of the French Statistical Society of Statistics [35] and in the international conference on computational statistics [34].

6.19. Conditional quantile estimator based on optimal quantization: from theory to practice

Participants: Isabelle Charlier, Jérôme Saracco.

[21] recently introduced a promising nonparametric estimator of conditional quantiles based on optimal quantization, but almost exclusively focused on its theoretical properties. We now discuss its practical implementation (by proposing in particular a method to properly select the corresponding smoothing parameter, namely the number of quantizers) and (ii) we investigate how its finite-sample performances compare with those of classical kernel or nearest-neighbor competitors. Monte Carlo studies show that the quantization-based estimator competes well in all cases (in terms of mean squared errors) and tends to dominate its competitors as soon as the covariate is not uniformly distributed over its support. We also apply our approach to a real data set. While most of the paper focuses on the case of a univariate covariate, we also briefly discuss the multivariate case and provide an illustration for bivariate regressors. This work is in collaboration with Davy Paindaveine from Université Libre de Bruxelles. It has been presented in the national conference of the French Statistical Society of Statistics [35] and in the international conference on computational statistics [34].

6.20. QuantifQuantile : an R package for performing quantile regression through optimal quantization

Participants: Isabelle Charlier, Jérôme Saracco.

Quantile regression allows to assess the impact of some covariate X on a response Y . An important application is the construction of reference curves and conditional prediction intervals for Y . Recently, [21] developed a new nonparametric quantile regression method based on the concept of optimal quantization. We now describe an R package, called QuantifQuantile, that allows to perform quantization-based quantile regression. We describe the various functions of the package and provide examples. This work is in collaboration with Davy Paindaveine from Université Libre de Bruxelles. It has been presented in the national conference on the R software [43].

6.21. Transcriptome profile analysis reveals specific signatures of pollutants in Atlantic eels

Participant: Jérôme Saracco.

Identifying specific effects of contaminants in a multi-stress field context remain a challenge in ecotoxicology. In this context, "omics" technologies, by allowing the simultaneous measurement of numerous biological endpoints, could help unravel the in situ toxicity of contaminants. In this study, wild Atlantic eels were sampled in 8 sites presenting a broad contamination gradient in France and Canada. The global hepatic transcriptome of animals was determined by RNA-Seq. In parallel, the contamination level of fish to 8 metals and 25 organic pollutants was determined. Factor analysis for multiple testing was used to identify genes that are most likely to be related to a single factor. Among the variables analyzed, arsenic (As), cadmium (Cd), lindane (γ -HCH) and the hepato-somatic index (HSI) were found to be the main factors affecting eel's transcriptome. Genes associated with As exposure were involved in the mechanisms that have been described during As vasculotoxicity in mammals. Genes correlated with Cd were involved in cell cycle and energy metabolism. For γ -HCH, genes were involved in lipolysis and cell growth. Genes associated with HSI were involved in protein, lipid and iron metabolisms. Our study proposes specific gene signatures of pollutants and their impacts in fish exposed to multi-stress conditions.

This work is in collaboration with G. Durrieu from Vannes University and R. Coudret. It will be published in *Ecotoxicology* [17].

6.22. Comparaison of kernel density estimators with assumption on number of modes : application on environmental monitoring data

Participant: Jérôme Saracco.

A data-driven bandwidth choice for a kernel density estimator called critical bandwidth is investigated. This procedure allows the estimation to have as many modes as assumed for the density to estimate. Both Gaussian and uniform kernels are considered. For the Gaussian kernel, asymptotic results are given. For the uniform kernel, an argument against these properties is mentioned. These theoretical results are illustrated with a simulation study that compares the kernel estimators that rely on critical bandwidth with another one that uses a plug-in method to select its bandwidth. An estimator that consists in estimates of density contour clusters and takes assumptions on number of modes into account is also considered. Finally, the methodology is illustrated using environment monitoring data.

This work is in collaboration with G. Durrieu from Vannes University and R. Coudret. It will be published in *Communication in Statistics - Simulation and Computation* [28].

6.23. A new sliced inverse regression method for multivariate response

Participant: Jérôme Saracco.

A semiparametric regression model of a q -dimensional multivariate response y on a p -dimensional covariate x is considered. A new approach is proposed based on sliced inverse regression (SIR) for estimating the effective dimension reduction (EDR) space without requiring a prespecified parametric model. The convergence at rate square root of n of the estimated EDR space is shown. The choice of the dimension of the EDR space is discussed. Moreover, a way to cluster components of y related to the same EDR space is provided. Thus, the proposed multivariate SIR method can be used properly on each cluster instead of blindly applying it on all components of y . The numerical performances of multivariate SIR are illustrated on a simulation study. Applications to a remote sensing dataset and to the Minneapolis elementary schools data are also provided. Although the proposed methodology relies on SIR, it opens the door for new regression approaches with a multivariate response.

This work is in collaboration with S. Girard from Inria MISTIS team and R. Coudret. It is published in *CSDA* [23].

6.24. An introduction to dimension reduction in nonparametric kernel regression

Participant: Jérôme Saracco.

Nonparametric regression is a powerful tool to estimate nonlinear relations between some predictors and a response variable. However, when the number of predictors is high, nonparametric estimators may suffer from the curse of dimensionality. In this chapter, we show how a dimension reduction method (namely Sliced Inverse Regression) can be combined with nonparametric kernel regression to overcome this drawback. The methods are illustrated both on simulated datasets as well as on an astronomy dataset using the R software [51].

This work is in collaboration with S. Girard from Inria MISTIS team .

6.25. Hidden Markov Model for the detection of a degraded operating mode of optronic equipment

Participant: Jérôme Saracco.

As part of optimizing the reliability, Thales Optronics now includes systems that examine the state of its equipment. The aim of this paper is to use hidden Markov Model to detect as soon as possible a change of state of optronic equipment in order to propose maintenance before failure. For this, we carefully observe the dynamic of a variable called "cool down time" and noted Tmf, which reflects the state of the cooling system. Indeed, the Tmf is an indirect observation of the hidden state of the system. This one is modelled by a Markov chain and the Tmf is a noisy function of it. Thanks to filtering equations, we obtain results on the probability that an appliance is in degraded state at time t, knowing the history of the Tmf until this moment. We have evaluated the numerical behavior of our approach on simulated data. Then we have applied this methodology on our real data and we have checked that the results are consistent with the reality. This method can be implemented in a HUMS (Health and Usage Monitoring System). This simple example of HUMS would allow the Thales Optronics Company to improve its maintenance system. This company will be able to recall appliances which are estimated to be in degraded state and do not control to soon those estimated in stable state.

This work is in collaboration with A. Gegout-Petit from Lorraine University. It is published in Journal de la SFdS [19].

6.26. On the asymptotic behavior of the Nadaraya-Watson estimator associated with the recursive SIR method

Participant: Jérôme Saracco.

We investigate the asymptotic behavior of the Nadaraya-Watson estimator for the estimation of the regression function in a semiparametric regression model. On the one hand, we make use of the recursive version of the sliced inverse regression method for the estimation of the unknown parameter of the model. On the other hand, we implement a recursive Nadaraya-Watson procedure for the estimation of the regression function which takes into account the previous estimation of the parameter of the semiparametric regression model. We establish the almost sure convergence as well as the asymptotic normality for our Nadaraya-Watson estimator. We also illustrate our semiparametric estimation procedure on simulated data.

This work is in collaboration with B. Bercu from Bordeaux University and T.M.N Nguyen. It is published in Statistics [20].

6.27. Evolving Genetic Programming Classifiers with Novelty Search

Participants: Enrique Naredo, Leonardo Trujillo, Pierrick Legrand.

Novelty Search (NS) is a unique approach towards search and optimization, where an explicit objective function is replaced by a measure of solution novelty to provide the selective pressure in an artificial evolutionary system. However, NS has been mostly used in evolutionary robotics, while its applicability to classic machine learning problems has been mostly unexplored. This work presents a NS-based Genetic Programming (GP) algorithm for supervised classification, with the following noteworthy contributions. It is shown that NS can solve real-world classification tasks, validated over several commonly used benchmarks. These results are made possible by using a domain-specific behavioral descriptor, closely related to the concept of semantics in GP. Moreover, two new variants of the NS algorithm are proposed, Probabilistic NS (PNS) and a variant of Minimum Criterion NS (MCNS). The former models the behavior of each solution as a random vector, eliminating all the NS parameters and reducing the computational overhead of the traditional NS algorithm; the latter uses a standard objective function to constrain the search and bias the process towards high performance solutions. The paper also discusses the effects of NS on an important GP phenomenon, bloat. In particular, results indicate that some variants of the NS approach can have a beneficial effect on the search process by curtailing code growth. See [52].

6.28. Detecting mental states of alertness with genetic algorithm variable selection

Participants: Laurent Vezard, Pierrick Legrand, Marie Chavent, Frédérique Faïta, Leonardo Trujillo.

The objective of the present work is to develop a method that is able to automatically determine mental states of vigilance; i.e., a person's state of alertness. Such a task is relevant to diverse domains, where a person is expected or required to be in a particular state of mind. For instance, pilots and medical staff are expected to be in a highly alert state and the proposed method could help to detect possible deviations from this expected state. This work poses a binary classification problem where the goal is to distinguish between a "relaxed" state and a baseline state ("normal") from the study of electroencephalographic signals (EEG) collected with a small number of electrodes. The EEG of 58 subjects in the two alertness states (116 records) were collected via a cap with 58 electrodes. After a data validation step, 19 subjects were retained for further analysis. A genetic algorithm was used to select a subset of electrodes. Common spatial pattern (CSP) coupled to linear discriminant analysis (LDA) was used to build a decision rule and thus predict the alertness of the subjects. Different subset sizes were investigated and the best compromise between the number of selected electrodes and the quality of the solution was obtained by considering 9 electrodes. Even if the present approach is costly in computation time (GA search), it allows to construct a decision rule that provides an accurate and fast prediction of the alertness state of an unseen individual. See [45], [54].

6.29. A comparison of fitness-case sampling methods for Symbolic Regression

Participants: Yuliana Martinez, Leonardo Trujillo, Enrique Naredo, Pierrick Legrand.

The canonical approach towards fitness evaluation in Genetic Programming (GP), is to use a static training set to determine fitness, based on a cost function (root-mean-squared error) averaged over all cases. However, motivated by different goals, researchers have recently proposed several techniques that focus selective pressure on a subset of fitnesscases at each generation. These approaches can be described as fitnesscase sampling techniques, where the training set is sampled, in some way, to determine fitness. This paper shows a comprehensive evaluation of some sampling methods using benchmark problems and real-world problems. The algorithms considered here are Interleaved Sampling, Random Interleaved Sampling, Lexicase Selection and a new sampling technique is proposed called Keep-Worst Interleaved Sampling (KW-IS). The algorithms are extensively evaluated based on test performance, overfitting and bloat. Results suggest that sampling techniques can improve performance based on testing error, bloat and overfitting compared to standard GP. Some of the best results were achieved by Lexicase Selection and Keep Worst-Interleaved Sampling which obtained good results in overfitting and bloat effect. Results also show that on these problems overfitting correlates strongly with bloating and exhibits a good compromise among the considered performance measures.

6.30. Geometric Semantic Genetic Programming with Local Search

Participants: Emigdio Z. Flores, Leonardo Trujillo, Leonardo Vanneshi, Sara Silva, Pierrick Legrand.

Since its introduction, Geometric Semantic Genetic Programming (GSGP) has aroused the interest of numerous researchers and several studies have demonstrated that GSGP is able to effectively optimize training data by means of small variation steps, that also have the effect of limiting overfitting. In order to speed up the search process, in this paper we propose a system that integrates a local search strategy into GSGP (called GSGP-LS). Furthermore, we present a hybrid approach, that combines GSGP and GSGP-LS, aimed at exploiting both the optimization speed of GSGP-LS and the ability to limit overfitting of GSGP. The experimental results we present, performed on a set of complex real-life applications, show that GSGP-LS achieves the best training fitness while converging very quickly, but severely overfits; GSGP converges very slowly, but is basically not affected by overfitting. The best overall results were achieved with the hybrid approach, allowing the search to converge quickly, while also exhibiting a noteworthy ability to limit overfitting. These results are encouraging, and suggest that future GSGP algorithms should focus on finding the correct balance between the greedy optimization of a local search strategy and the more robust geometric semantic operators.

MATHRISK Project-Team

6. New Results

6.1. Highlights of the Year

B. Jourdain and A. Sulem : Guest editors of the special issue "Systemic Risk" of *Statistics and Risk Modeling*, 2014. [27]

The research project "Stochastic Control of Systemic Risk" has been awarded by the scientific council and Professional Fellows of Institut Europlace de Finance (EIF) and Labex Louis Bachelier (December 2014).

Roxana Dumitrescu, PhD student, received the price for collaborative actions during her PhD studies, delivered by Fondation des Sciences Mathématiques de Paris and CASDEN (November 2014).

Pierre Blanc, PhD student, has got the award of "Rising star of quantitative finance" for his talk on a price impact models with an exogeneous (Hawkes) flow of orders [29]. This prize was given by the Global Derivatives conference (Amsterdam, 12-16 May) to indicate the best work among PhD students.

6.2. Liquidity risk

Aurélien Alfonsi and his PhD student Pierre Blanc are working on the optimal execution problem when there are many large traders who modify the price. They consider an Obizhaeva and Wang model for the price impact, and they assume that the flow of market orders generated by the other traders is given by an exogenous process. They have shown that Price Manipulation Strategies (PMS) exist when the flow of order is a compound Poisson process. On the other hand, modeling this flow by a mutually exciting Hawkes process allows them with a particular parametrization to exclude these PMS. Besides, they are able to calculate explicitly the optimal execution strategy within the model [29]. They are now investigating how this model can fit market data.

6.3. Dependence modeling

With his PHD student J. Reygner, B. Jourdain has studied a mean-field version of rank-based models of equity markets, introduced by Fernholz in the framework of stochastic portfolio theory ([38]). When the number of companies grows to infinity, they obtain an asymptotic description of the market in terms of a stochastic differential equation nonlinear in the sense of McKean. The diffusion and drift coefficients depend on the cumulative distribution function of the current marginal law of the capitalizations. Using results on the longtime behavior of such SDEs derived in [66], they discuss the long-term capital distribution in this asymptotic model, as well as the performance of simple portfolio rules. In particular, they highlight the influence of the volatility structure of the model on the growth rates of portfolios.

Another approach to handle the question of stochastic modeling in a multidimensional framework consists in dealing with stochastic differential equations that are defined on matrices in order to model either the instantaneous covariance or the instantaneous correlation between the assets.

The research on the estimation of the parameters of a Wishart process has started this year together with the thesis of Clément Rey. A. Alfonsi, A. Kebaier and C. Rey are studying the Maximum Likelihood Estimator for the Wishart processes and in particular its convergence in the ergodic and the non ergodic case.

Correlation issues are crucial in the modeling of volatility. In his thesis, Ould Aly ([77]) proposes a revised version of Bergomi's model for the variance curve which proves to be very tractable for calibration and for the pricing of variance derivatives (see [23]). He also obtains results on the monotonicity of option prices with respect to the correlation between the stock price and the volatility in the Heston model (see [78]).

In [34], [15], L. Abbas-Turki and D. Lamberton study the monotonicity of option prices with respect to cross-asset correlations in a multidimensional Heston model.

Modeling the dependence is not only useful for the equity market. In credit risk, getting a model that describes the dynamic of the joint distribution of a basket of defaults is still a challenge. The Loss Intensity model proposed by Schönbucher allows to fit perfectly the marginal distributions of the number of defaults in a basket. Then, Stochastic Loss Intensity models extend this model and can also in principle fit the marginal distributions. However, these models appear as a non-linear differential equation with jumps. A Alfonsi, C. Labart and J. Lelong have shown that these models are well-defined by using a particles system ([44]). Besides, this particles system gives a very convenient way to run a Monte-Carlo algorithm and to compute expectations in this model. Interacting particle systems are studied by B. Jourdain and his PhD student Julien Reygner in [39], [21].

Application of optimal transport. A. Alfonsi and B. Jourdain study in [43] the Wasserstein distance between two probability measures in dimension n sharing the same copula C . The image of the probability measure dC by the vectors of pseudo-inverses of marginal distributions is a natural generalization of the coupling known to be optimal in dimension $n = 1$. In dimension $n > 1$, it turns out that for cost functions equal to the p -th power of the L^q norm, this coupling is optimal only when $p = q$ i.e. when the cost function may be decomposed as the sum of coordinate-wise costs.

6.4. Systemic risk

The mathematical modeling of default contagion, by which an economic shock causing initial losses and default of a few institutions is amplified due to complex linkages, leading to large scale defaults, can be addressed by various techniques, such as network approaches (see in particular [46]), or mean field interaction models [62], [55]. Little has been done so far on the *control* of such systems and A. Sulem has started to contribute on these issues in the framework of random graph models in collaboration with A. Minca (Cornell University) and H. Amini (EPFL). In [22], [31], they consider a financial network described as a weighted directed graph, in which nodes represent financial institutions and edges the exposures between them. Here, the distress propagation is modeled as an epidemics on this graph. They study the optimal intervention of a lender of last resort who seeks to make equity infusions in a banking system prone to insolvency and to bank runs, under complete and incomplete information of the failure cluster, in order to minimize the contagion effects.

R. Elie is studying risk systemic propagation and its links with mean field games.

6.5. Backward stochastic (partial) differential equations with jumps and stochastic control with nonlinear expectation

A. Sulem, M.C. Quenez and R. Dumitrescu have studied optimization problems for BSDEs with jumps [11], optimal stopping for dynamic risk measures induced by BSDEs with jumps and associated reflected BSDEs. [24], [80], [19]. They have also investigated optimal stopping with nonlinear expectation under ambiguity, and their links with nonlinear Hamilton Jacobi Bellman variational inequalities in the Markovian case. Moreover they have obtained dynamic programming principles for mixed optimal-stopping problems with nonlinear expectations. They have also explored the links between generalized Dynkin games and double barriers reflected BSDE with jumps [56]. Stochastic control of Itô-Lévy Processes with applications to finance are studied by A. Sulem and B. Øksendal in [25], [26]. We have also contributed to the theory of BSDEs and Forward-Backward SDEs which appear as the adjoint equations associated to stochastic maximum principles, and address various issues about the relation between information and performance in non Markovian stochastic control: In particular, in the context of jump-diffusion models under partial information, A. Sulem, C. Fontana and B. Øksendal study in [20] the relation between market viability (in the sense of solvability of portfolio optimization problems) and the existence of a martingale measure given by the marginal utility of terminal wealth, without a-priori assuming no-arbitrage restrictions on the model.

A. Sulem, with B. Øksendal and T. Zhang has studied optimal stopping for Stochastic Partial Differential equations and associated reflected SPDEs [91], and optimal control of Forward-Backward SDEs [90].

Stochastic maximum principles for singular mean-field games are obtained in [37] with applications to optimal irreversible investments under uncertainty.

R. Dumitrescu and C. Labart have proposed a numerical approximation for Doubly Reflected BSDEs with Jumps and RCLL obstacles [35].

R. Elie studies approximate hedging prices under various risk constraints. This is done in collaboration with P. Briand, Y. Hu, A. Matoussi, B. Bouchard, L. Moreau, J.F. Chassagneux, I. Kharroubi and R. Dumitrescu.

6.6. Option Pricing

Interest rates modeling. A. Alfonsi studies an affine term structure model for interest rates that involve Wishart diffusions (with E. Palidda) [28]. Affine term structure models (Dai and Singleton, Duffie, ...) consider vector affine diffusions. Here, we extend the Linear Gaussian Model (LGM) by including some Wishart dynamics, and to get a model that could better fit the market. We have obtained a price expansion around the LGM for Caplet and Swaption prices. Also, we present a second order discretization scheme that allow to calculate exotic prices with this model.

American Options. In joint work with Aych Bouselmi, D. Lamberton studied the asymptotic behavior of the exercise boundary near maturity for American put options in exponential Lévy models [34].

He is currently working with M. Pistorius on the approximation of American options by Canadian options, which originated from the work of Peter Carr.

Barrier Options. Numerical pricing of double barrier options is investigated by A. Zanette and coauthors in [16].

6.7. Discretization of stochastic differential equations

With his PhD student A. Al Gerbi and E. Clément, B. Jourdain is interested in the strong convergence properties of the Ninomiya-Victoir scheme which is known to exhibit order 2 of weak convergence. This study is aimed at analysing the use of this scheme either at each level or only at the finest level of a multilevel Monte Carlo estimator : indeed, the variance of a multilevel Monte Carlo estimator is related to the strong error between the two schemes used in the coarse and fine grids at each level. They prove strong convergence with order 1/2 which is improved to order 1 when the vector fields corresponding to each Brownian coordinate in the SDE commute. They also check that the renormalized errors converge to affine SDEs with source terms involving the Lie brackets between these vector fields and, in the commuting case, their Lie brackets with the drift vector field. Last, they propose a modified Ninomiya-Victoir scheme, which, at the finest level of the multilevel Monte Carlo estimator, may be coupled with strong order 1 to a simpler scheme with weak order 1 recently proposed by Giles and Szpruch.

Using optimal transport tools, A. Alfonsi, B. Jourdain and A. Kohatsu-Higa have proved that the Wasserstein distance between the time marginals of an elliptic SDE and its Euler discretization with N steps is not larger than $\frac{C\sqrt{\log(N)}}{N}$. The logarithmic factor may be removed when the uniform time-grid is replaced by a grid still counting N points but refined near the origin of times [4]. To generalize in higher dimension the result that they obtained previously in dimension one using the optimality of the explicit inverse transform, they compute the derivative of the Wasserstein distance with respect to the time variable using the theory developed by Ambrosio Gigli and Savare. The abstract properties of the optimal coupling between the time marginals then enable them to estimate this time derivative [30].

6.8. Advanced Monte Carlo methods.

- **Adaptive variance reduction methods.** B. Jourdain and J. Lelong have pursued their work on adaptive Monte Carlo methods in several directions [17], [36].

- **Metropolis Hastings algorithm in large dimension.** With T. Lelièvre and B. Miasojedow, B. Jourdain considers the Random Walk Metropolis algorithm on \mathbf{R}^n with Gaussian proposals, and when the target probability measure is the n -fold product of a one dimensional law. It is well-known that, in the limit n tends to infinity, starting at equilibrium and for an appropriate scaling of the variance and of the timescale as a function of the dimension n , a diffusive limit is obtained for each component of the Markov chain. They generalize this result when the initial distribution is not the target probability measure ([65]). The obtained diffusive limit is the solution to a stochastic differential equation nonlinear in the sense of McKean. In [64], they prove convergence to equilibrium for this equation. They also discuss practical counterparts in order to optimize the variance of the proposal distribution to accelerate convergence to equilibrium. The analysis confirms the interest of the constant acceptance rate strategy (with acceptance rate between 1/4 and 1/3).

6.9. Numerical Probability

6.9.1. Regularity of probability laws using an interpolation method

This work was motivated by previous studies by N. Fournier, J. Printemps, E. Clément, A. Debusche and V. Bally, on the regularity of the law of the solutions of stochastic differential equations with low regularity coefficients - such as diffusion processes with Hölder coefficients or many other examples including jump type equations, Boltzmann equation or Stochastic PDE's. Since we do not have sufficient regularity, the usual approach by Malliavin calculus fails in this framework. We use the following alternative idea: We approximate the law of the random variable X (the solution of the equation at hand) by a sequence $X(n)$ of random variables which are smooth. Consequently we are able to establish integration by parts formulas for $X(n)$, to obtain the absolute continuity of the law of $X(n)$, and to establish estimates for the density of the law of $X(n)$ and its derivatives. Note that the derivatives of the densities of $X(n)$ generally blow up - so we can not derive directly results concerning the density of the law of X . But, if the speed of convergence of $X(n)$ to X is faster than the blow up, then we may obtain results concerning the density of the law of X . It turns out that this approach fits in the framework of interpolation spaces and that the criterion of regularity for the law of X amounts to the characterization of an interpolation space between a space of distributions and a space of smooth functions. Although the theory of interpolation spaces is very well developed and one already knows how to characterize the interpolation spaces for Sobolev spaces of positive and negative indices, we have not found in the (huge) literature a result which covers the problem we are concerned with. So, although our result may be viewed as an interpolation result, it is a new one. The above work is treated in the paper [48] by V. Bally and Lucia Caramellino. As an application we discussed in [50] the regularity of the law of a Wiener functional under a Hörmander type non degeneracy condition.

6.9.2. A stochastic parametrix representation for the density of a Markov process.

Classical results of PDE theory (due to A. Friedmann) assert that, under uniform ellipticity conditions, the law of a diffusion process has a continuous density (the approach of A. Friedmann is analytical and concerns PDE's instead of the corresponding diffusion process). The method developed by A. Friedmann is known as the "parametrix method". V. Bally In collaboration with A. Kohatsu Higa gave a probabilistic approach which represents the probabilistic counterpart of the parametrix method [33]. They obtained a probabilistic representation for the density of the law of the solution of a SDE and more generally, for a class of Markov processes including solutions of jump type SDE's. This representation may be considered as a perfect simulation scheme and so represents a starting point for Monte Carlo simulation. However the random variable which appears in the stochastic representation has infinite variance, so direct simulation gives unstable results (as some preliminary tests have proved). In order to obtain an efficient simulation scheme some more work on the reduction of variance has to be done - and this does not seem trivial.

6.9.3. The distance between two density functions and convergence in total variation.

V. Bally and L. Caramellino have obtained estimates of the distance between the densities of the law of two random variables using an abstract variant of Malliavin calculus. They used these estimates in order to

study the convergence in total variation of a sequence of random variables. This has been done in [49]. They are now working on more specific examples concerning the Central Limit Theorem [32]. In the last years the convergence in entropy distance and in total variation distance for several variants of the CLT has been considered in papers by S. Bobkov, F. Götze, G. Peccati, Y. Nourdin, D. Nualart and G. Poly. This is a very active research. Moreover, in an working paper in collaboration with his Phd student R. Clement, V. Bally uses similar methods in order to study the total variation distance between two Markov semigroups and for approximation schemes purposes. A special interest is devoted to higher order schemes such as the Victorin Nyomia scheme.

6.9.4. An invariance principle for stochastic series (U- Statistics).

Vlad Bally and Lucia Caramellino are working on invariance principles for stochastic series of polynomial type. In the case of polynomials of degree one we must have the classical Central Limit Theorem (for random variables which are not identically distributed). For polynomials of higher order we are in the framework of the so called U statistics which have been introduced by Hoffdings in t 1948 and which play an important role in modern statistics. Our contribution in this topic concerns convergence in total variation distance for this type of objects. We use abstract Malliavin calculus and more generally, the methods mentioned in the above paragraph.

REGULARITY Project-Team

6. New Results

6.1. Highlights of the Year

The article "Christiane's Hair" by Jacques Lévy-Véhel and Franklin Mendivil has received the Paul R. Halmos - Lester R. Ford award of the Mathematical Association of America.

6.2. Modelling the exchange of cultural goods on the Internet

Participant: Jacques Lévy Véhel.

In collaboration with Pierre Emmanuel Lévy Véhel and Victor Lévy Véhel.

Illegal sharing of cultural goods on the Internet has become a massive reality in today's connected society. Numerous studies have been performed to try and evaluate the impact of these practices on the industry of cultural goods, and how much harm, if any, they have entailed. The effect of legal and technical responses to limit pirating has also been investigated, showing in general inconclusive effect. Instead of penalizing illegal actors - providers and/or consumers -, a totally different approach has been proposed recently by the french government agency Hadopi. The idea is to offer the possibility to sites that illegally share cultural goods to become legal in exchange of a retribution proportional to their activity. In the frame of a contract with the Hadopi, we have built a model that studies the economic feasibility of such a scheme under various assumptions on the behaviour of the different actors involved. Our main finding is that, supposing that more popular goods are more prone to pirating, a retribution of the order of the increase in benefit per user gained by legalized sites does indeed lead to a win-win situation for both producers/sellers of cultural goods and willing-to-be-legalized sites. This will be the case under two conditions: the proportion of pirates is large enough (which seems largely true) and the increase in the amount of money that forums will make from advertisement when becoming legal is sufficient [43].

An extension of our work is under way, that will consider further actors and refined modelling of the way illegal sharing takes place. Calibration issues will also be investigated more closely.

6.3. Financial risk analysis

Participant: Jacques Lévy Véhel.

Financial regulations have fundamentally changed since the Basel II Accords. Among other evolutions, Basel II and III explicitly impose that computations of capital requirements be model-based. This paradigm shift in risk management has been the source of strong debates among both practitioners and academics, who question whether such model-based regulations are indeed more efficient.

A common feeling in the industry is that regulations will sometimes give a false impression of security: risk manager tend to think that a financial company that would fulfil all the criteria of, say, the Basel III Accords on capital adequacy, is not necessarily on the safe side. This is so mainly because many risks, and most significantly systemic or system-wide risks, are not properly modelled, and also because it is easy to manipulate to some extent various risk measures, such as VaR.

In parallel, a fast growing body of academic research provides various arguments explaining why current regulations are not well fitted to address risk management in an adequate way, and may even, in certain cases, worsen the situation.

We use the term *regulation risk* to describe the fact that, in some situations, prudential rules are themselves the source of a systemic risk. We have shown how a combination of model risk and regulation risk leads to an effect which is exactly the opposite of what the regulator tries to enforce. More precisely, we explain how wrongly assuming a Gaussian dynamics (or, more generally, a left-light-tailed one) when the “true” one is pure jump (or, more generally, left-heavy-tailed), and imposing as a constraint *minimizing* VaR at constant volume results in effect in movements that will *maximize* VaR. This effect is related to the fact that regulations fail to consider that risk is endogenous. In a nutshell, the idea is simply that, by treating jumps in the evolution of prices as exceptional events and essentially ignoring them in model-based VaR computations, one misses an essential dimension of risk, and acts in a way that will in effect favour sudden large movements in the markets and ultimately increase VaR. Our simple setting predicts that VaR constraints result in an *increased* intensity of jumps and a *decrease* in volatility - a fact confirmed experimentally on certain datasets. This is a mathematical translation of the common feeling of practitioners that regulations give a false impression of security characterized by low volatility but increased risk of sudden large movements.

6.4. Functional central limit theorem for multistable Lévy motions

Participants: Xiequan Fan, Jacques Lévy Véhel.

We prove a functional central limit theorem (FCLT) for the independent-increments multistable Lévy motions (MsLM) $L_I(t), t \in [0, 1]$, as well as of integrals with respect to these processes, using weighted sums of independent random variables. In particular, we prove that multistable Lévy motions are stochastic Hölder continuous and strongly localisable.

Theorem 0.1 Let $(\alpha_n(u))_n, \alpha(u), u \in [0, 1]$, be a class of càdlàg functions ranging in $[a, b] \subset (0, 2]$ such that the sequence $(\alpha)_n$ tends to α in the uniform metric. Let $(X(k, n))_{n \in \mathbb{N}, k=1, \dots, 2^n}$ be a family of independent and symmetric $\alpha_n(\frac{k}{2^n})$ -stable random variables with unit scale parameter, i.e., $X(k, n) \sim S_{\alpha_n(\frac{k}{2^n})}(1, 0, 0)$. Then the sequence of processes

$$L_I^{(n)}(u) = \sum_{k=1}^{\lfloor 2^n u \rfloor} \left(\frac{1}{2^n} \right)^{1/\alpha_n(\frac{k}{2^n})} X(k, n), \quad u \in [0, 1], \quad (8)$$

tends in distribution to $L_I(u)$ in $(D[0, 1], d_S)$, where $\lfloor x \rfloor$ is the largest integer smaller than or equal to x . In particular, if α satisfies

$$(\alpha(x) - \alpha(x+t)) \ln t \rightarrow 0 \quad (9)$$

uniformly for all x as $t \searrow 0$, then $L_I(u)$ is localisable at all times.

We have defined integrals of MsLM, and given criteria for convergence, independence, stochastic Hölder continuity and strong localisability of such integrals.

6.5. Deviation inequalities for martingales with applications

Participant: Xiequan Fan.

In the papers [36], [37] we study some general exponential inequalities for supermartingales. The inequalities improve or generalize many exponential inequalities of Bennett (1962), Freedman (1975), van de Geer (1995), de la Peña (1999) and Pinelis (2006). Moreover, our concentration inequalities also improve some known inequalities for sums of independent random variables. Applications associated with linear regressions, autoregressive processes and branching processes are provided. In particular, an interesting application of de la Peña’s inequality to self-normalized deviations is also provided.

We also considered an \mathcal{X} -valued Markov chain X_1, X_2, \dots, X_n belonging to a class of iterated random functions, which is “one-step contracting” with respect to some distance d on \mathcal{X} . If f is any separately Lipschitz function with respect to d , we use a well known decomposition of $S_n = f(X_1, \dots, X_n) - \mathbb{E}[f(X_1, \dots, X_n)]$ into a sum of martingale differences d_k with respect to the natural filtration \mathcal{F}_k . We show that each difference d_k is bounded by a random variable η_k independent of \mathcal{F}_{k-1} . Using this very strong property, we obtain a large variety of deviation inequalities for S_n , which are governed by the distribution of the η_k 's. Finally, we give an application of these inequalities to the Wasserstein distance between the empirical measure and the invariant distribution of the chain.

6.6. Self-stabilizing Lévy motions

Participants: Xiequan Fan, Jacques Lévy Véhel.

Self-stabilizing processes have the property that the “local intensities of jumps” varies with amplitude. They are good models for, e.g., financial and temperature records.

The main aim of our work is to establish the existence of such processes and to give a simple construction. Formally, one says that a stochastic process $S(t), t \in [0, 1]$, is a self-stabilizing process if, for almost surely all $t \in [0, 1]$, S is localisable at t with tangent process S'_t an $g(S(t))$ -stable process, with respect to the conditional probability measure $\mathbb{P}_{S(t)}$. In other words,

$$\lim_{r \searrow 0} \frac{S(t+ru) - S(t)}{r^{1/g(S(t))}} = S'_t(u), \quad (10)$$

where convergence is in finite dimensional distributions with respect to $\mathbb{P}_{S(t)}$. Heuristically, if $S'_t(u) = L_{g(S(t))}(u)$, equality (8) implies that

$$S(t+ru) - S(t) \approx r^{1/g(S(t))} L_{g(S(t))}(u) = (ru)^{1/g(S(t))} L_{g(S(t))}(1),$$

when r is small. Thus it is natural to define $S(t) = \lim_{n \rightarrow \infty} S_n(\frac{[nt]}{n})$, where

$$S_n\left(\frac{k+1}{n}\right) - S_n\left(\frac{k}{n}\right) = n^{-1/g(S_n(k/n))} L_{g(S_n(k/n))}(1).$$

This inspiration allows us to build Markov processes that converge to a self-stabilizing process. Note that, when $\alpha(x) \equiv 2$, this is simply Donsker's construction. The main difficulty is to prove the weak convergence of S_n . To this aim, we make use of a generalization of the Arzelà-Ascoli theorem.

Definition 0.1 We call the sequence $(f_n(\theta))_{n \geq 1}$ is sub-equicontinuous on $I \subset \mathbb{R}^d$, if for any $\varepsilon > 0$, there exist $\delta > 0$ and a sequence of nonnegative numbers $(\varepsilon_n)_{n \geq 1}, \varepsilon_n \rightarrow 0$ as $n \rightarrow \infty$, such that, for all functions f_n in the sequence,

$$|f_n(\theta_1) - f_n(\theta_2)| \leq \varepsilon + \varepsilon_n, \quad \theta_1, \theta_2 \in I, \quad (11)$$

whenever $\|\theta_1 - \theta_2\| < \delta$ (if $\varepsilon_n = 0$ for all n , then $(f_n(\theta))_{n \geq 1}$ is just equicontinuous).

The slightly generalized version of the Arzelà-Ascoli theorem reads:

Lemma 0.1 Assume that $(f_n)_{n \geq 1}$ be a sequence of real-valued continuous functions defined on a closed and bounded set $\prod_{i=1}^d [a_i, b_i] \subset \mathbb{R}^d$. If this sequence is uniformly bounded and sub-equicontinuous, then there exists a subsequence $(f_{n_k})_{k \geq 1}$ that converges uniformly.

The following theorem states that self-stabilizing processes do exist.

Theorem 0.2 Let g be a Hölder function defined on \mathbb{R} and ranging in $[a, b] \subset (0, 2]$. There exists a self-stabilizing process $S(t), t \in [0, 1]$, that it is tangent at all u to a $g(S(u))$ -stable Lévy process under the conditional expectation with respect to $S(u)$. Moreover, the process $S(t), t \in [0, 1]$, satisfies, for all $(\theta_j, t_j) \in \mathbb{R} \times [0, 1], j = 1, 2, \dots, d$,

$$\mathbb{E}_{S(t_1)} \left[\exp \left\{ i \sum_{j=2}^d \theta_j (S(t_j) - S(t_1)) + \int \left| \sum_{j=2}^d \theta_j \mathbf{1}_{[t_1, t_j]}(z) \right|^{g(S(z))} dz \right\} \right] = 1. \quad (12)$$

We are currently studying the main properties of self-stabilizing processes.

TOSCA Project-Team

6. New Results

6.1. Probabilistic numerical methods, stochastic modelling and applications

Participants: Mireille Bossy, Nicolas Champagnat, Julien Claisse, Madalina Deaconu, Benoît Henry, James Inglis, Antoine Lejay, Oana Valeria Lupascu, Sylvain Maire, Sebastian Niklitschek Soto, Denis Talay, Etienne Tanré, Denis Villemonais.

6.1.1. Published works and preprints

- M. Bossy and J.-F. Jabir (University of Valparaíso) [13] have proved the well-posedness of a conditional McKean Lagrangian stochastic model, endowed with the specular boundary condition, and further the mean no-permeability condition, in a smooth bounded confinement domain \mathcal{D} .
- M. Bossy, N. Champagnat, S. Maire and L. Violeau worked with H. Leman (CMAP, Ecole Polytechnique) and M. Yvinec (Inria Sophia, EPI GEOMETRICA) on Monte Carlo methods for the linear and non-linear Poisson-Boltzmann equations [12]. These methods are based on walk on spheres algorithm, simulation of diffusion processes driven by their local time, and branching Brownian motion. Their code for the linear equation can deal with bio-molecules of arbitrary sizes, based on computational geometry tools from the CGAL C++ Library developed by the GEOMETRICA team. The non-linear equation is solved using branching Brownian motion.
- M. Bossy, O. Faugeras (Inria Sophia, EPI NEUROMATHCOMP), and D. Talay have clarified the well-posedness of the limit equations to the mean-field N -neuron models proposed in [42] and proven the associated propagation of chaos property. They also have completed the modeling issue in [42] by discussing the well-posedness of the stochastic differential equations which govern the behavior of the ion channels and the amount of available neurotransmitters. See [29].
- N. Champagnat and D. Villemonais obtained criterions for existence and uniqueness of quasi-stationary distributions and Q -processes for general absorbed Markov processes [31]. A quasi-stationary distribution is a stationary distribution conditionally on non-absorption, and the Q -process is defined as the original Markov process conditioned to never be absorbed. The criterion that they obtain ensures exponential convergence of the conditioned t -marginal of the process conditioned not to be absorbed at time t , to the quasi-stationary distribution and also the exponential ergodicity of the Q -process.
- M. Deaconu and S. Herrmann continued and completed the study of the simulation of the hitting time of some given boundary for Bessel processes. They constructed an original approximation method for hitting times of a given threshold by Bessel processes with non-integer dimension. In this work, they combine the additivity property of the laws of squared Bessel processes with their previous results on the simulation of hitting times of Bessel processes with integer dimension, based on the method of images and on the connexion with the Euclidean norm of the Brownian motion [33].
- M. Deaconu, S. Herrmann and S. Maire introduced a new method for the simulation of the exit time and position of a δ -dimensional Brownian motion from a domain. The main interest of this method is that it avoids splitting time schemes as well as inversion of complicated series. The idea is to use the connexion between the δ -dimensional Bessel process and the δ -dimensional Brownian motion thanks to an explicit Bessel hitting time distribution associated with a particular curved boundary. This allows to build a fast and accurate numerical scheme for approximating the hitting time [34].
- M. Deaconu and O. Lupaşcu worked with L. Beznea (Bucharest, Romania) on the construction and the branching properties of the solution of the fragmentation equation and properly associate a continuous time càdlàg Markov process. The construction and the proof of the path regularity of the Markov processes are based on several newly developed potential theoretic tools.

- J. Inglis, together with O. Faugeras (Inria NEUROMATHCOMP) finalized their article [18] on the well-posedness of stochastic neural field equations within a rigorous framework.
- J. Inglis and E. Tanré together with F. Delarue and S. Rubenthaler (Univ. Nice – Sophia Antipolis) finalized their article [16] on the global solvability of a networked system of integrate-and-fire neurons proposed in the neuroscience literature.
- J. Inglis and E. Tanré together with F. Delarue and S. Rubenthaler (Univ. Nice – Sophia Antipolis) completed their study of the mean-field convergence of a highly discontinuous particle system modeling the behavior of a spiking network of neurons, based on the integrate-and-fire model [17]. Due to the highly singular nature of the system, it was convenient to work with a relatively unknown Skorohod topology.
- J. Inglis and D. Talay introduced in [38] a new model for a network of spiking neurons that attempted to address several criticisms of previously considered models. In particular the new model takes into account the role of the dendrites, and moreover includes non-homogeneous synaptic weights to describe the fact that not all neurons have the same effect on the others in the network. They were able to obtain mean-field convergence results, using new probabilistic arguments.
- A. Lejay have worked with G. Pichot (EPI SAGE) on benchmarks for testing Monte Carlo methods to simulate particles in one-dimensional media, and applied this statistical methodology to four methods, including the exact method developed previously [45]. This work led also to empirical observations that should guide the design of new methods [24].
- S. Maire is working with the Bulgarian Academy of sciences on Monte Carlo algorithms for linear equations based on killed random walks. In a first work, with I. Dimov and J-M. Sellier [37], a new Monte Carlo method to solve linear systems of equations has been introduced. This method can either compute one component of the solution or all components simultaneously. In a second work, with Ivan Dimov and Rayna Georgieva, a new Monte Carlo method to solve Fredholm integral equations of the second kind is developed [36].
- D. Villemonais worked with P. Del Moral (Univ. Sydney) on the conditional ergodicity of time inhomogeneous diffusion processes [35]. They proved that, conditionally on non extinction, an elliptic time-inhomogeneous diffusion process forgets its initial distribution exponentially fast. An interacting particle scheme to numerically approximate the conditional distribution is also provided.
- D. Villemonais proved a Foster-Lyapunov type criterion which ensures the exponential ergodicity of a Fleming-Viot type particle system whose particles evolve as birth and death processes. The criterion also ensures the tightness of the sequence of empirical stationary distributions considered as a family of random measures. A numerical study of the speed of convergence of the particle system is also obtained under various settings [41].

6.1.2. Other works in progress

- M. Bossy and J-F. Jabir (University of Valparaíso) proved the validity of a particle approximation of a (simplified) Lagrangian Stochastic Model submitted to specular reflections at the boundary and satisfying the mean no-permeability condition. This work achieves to extend our previous study [43] to the multidimensional case.
- N. Champagnat and D. Villemonais obtained criterions for existence, uniqueness and exponential convergence in total variation of quasi-stationary distributions and Q -processes for general absorbed and killed diffusion processes. The criterion obtained is equivalent to the property that a diffusion on natural scale coming down from infinity has uniformly (w.r.t. the initial condition) bounded expectation at a fixed time t . A study of nearly critical cases allow to conjecture that this property is true for all diffusion processes on natural scale coming down from infinity. This work is currently being written.
- N. Champagnat and B. Henry worked on the long-time behavior of the frequency spectrum for the Splitting Tree models under the infinitely-many alleles model. They obtained, using a new method for computing the expectation of an integral with respect to a random measure, the asymptotic behavior

of the moments of the frequency spectrum. As an application, they derived the law of large number and a new central limit theorem for the frequency spectrum. This work is currently being written.

- J. Claisse defended his PhD. under the supervision of N. Champagnat and D. Talay on stochastic control of population dynamics. He completed a finite-horizon optimal control problem on branching–diffusion processes. He also created and studied a hybrid model of tumor growth emphasizing the role of acidity. Key therapeutic targets appear in the model to allow investigation of optimal treatment problems.
- J. Claisse and D. Talay in collaboration with X. Tan (Univ. of Paris Dauphine) extended their previous work on a pseudo-Markov property enjoyed by the solutions of controlled stochastic differential equations and its application to the proof of the dynamic programming principle. A paper is being finished.
- M. Deaconu and O. Lupascu are working with L. Beznea (Bucharest, Romania) on a stochastic model for avalanche phenomena involving rupture properties that occur in the physical and deterministic models for snow avalanches. This approach is based on their recent results on fragmentation processes by stochastic differential equation and branching processes.
- M. Deaconu and O. Lupascu are working on a numerical probabilistic algorithm for an avalanche-type process. The originality of this approach is to use a coagulation/fragmentation model to describe the avalanche phenomenon. More precisely, they consider a particular fragmentation kernel which introduces “rupture-type” properties of deterministic models for snow avalanches.
- An important issue in neuroscience is the modelling of spike trains of a single neuron. In this context, the membrane potential of a neuron can be described by using a simple stochastic differential equation with periodic input, that is reset to a rest potential each time it hits a certain threshold. J. Inglis, A. Richard, D. Talay, and E. Tanré study how the law of these hitting times is affected when one changes the white noise (in the SDE) into a correlated noise. Practically, they use a fractional Brownian motion, and since the computation of the hitting times of such a non-Markovian, non-semimartingale process is still an open question, they rather try to compute the deviations from the white noise model. This is expected to give insights on the relevance of models with memory and long-range dependence.
- J. Inglis started a collaboration with B. Hambly and S. Ledger at the University of Oxford, in which interacting mean-field particle systems with common noise are being studied. Such systems are representative of systems of spiking neurons or portfolio defaults. In previous studies each particle was driven by a noise that was assumed independent from particle to particle (i.e. intrinsic noise). By considering a common driving noise in addition to the intrinsic noise, it is possible to model the fact that the environment in which the particles live is also noisy. This leads to the study of a new type of conditional McKean-Vlasov equation.
- J. Inglis, in collaboration with J. Maclaurin (EPI NEUROMATHCOMP) and W. Stannat (Berlin), has begun working on a new framework to understand the effect of noise on neural field equations. Deterministic neural field equations exhibit traveling wave solutions, and so the effect of noise on these solutions is of great interest. The idea is to decompose the solution into various components, which allow one to see directly how the noise affects the solution in the direction of the moving wave front. In particular, the goal is to reconcile mathematically the previous works of P. Bressloff and W. Stannat on the same subject, and to obtain a large deviation principle.
- J. Inglis and D. Talay are in the process of studying the emergence of spatio-temporal noise starting from microscopic models of neuron conductance.
- A. Lejay continued his collaboration with S. Torres (Universidad de Valparaíso, Chile) and E. Mordecki (Universidad de la República, Uruguay) on the estimation of the parameter of the Skew Brownian motion. This work is related to the modelling of diffusion processes in media with interfaces and has potential applications in many domains, such as population ecology.

- Together with R. Rebolledo (Pontificia Universidad Católica, Santiago, Chile), A. Lejay continued his review work on the mathematical modelling of the Wave Energy Converter Called the Oscillating water column, within the framework of the CIRIC project.
- A. Lejay continued his work on the Snapping out Brownian motion to perform numerical tests for the computation of the mean residence time in a diffusive medium with semi-permeable membranes, such as the one encountered in the mathematical modelling of diffusion Magnetic Resonance Imaging.
- A. Lejay continued his collaboration with L. Coutin (Universté Paul Sabatier, Toulouse) on the sensitivity of rough linear differential equations, by providing general results on the derivatives of the solution of rough differential equations with respect to parameters or the starting point.
- S. Niklitschek Soto and D. Talay completed their stochastic analysis of diffraction parabolic PDEs with general discontinuous coefficients in the multidimensional case.
- P. Guiraud (University of Valparaíso) and E. Tanré study the effect of noise in the phenomenon of spontaneous synchronisation in a network of connected leaky integrate-and-fire neurons. They detail cases in which the phenomenon of synchronization persists in a noisy environment, cases in which noise permits to accelerate synchronization, and cases in which noise permits to observe synchronization while the noiseless model does not show synchronization. (Math Amsud program SIN)
- O. Faugeras (EPI NEUROMATHCOMP) and E. Tanré worked on an extension of [44] to a context of several populations of homogeneous neurons. They study the limit mean field equation of the membrane potential as the number of neurons increases in a network with correlated synaptic weights. A paper is in preparation.
- C. Graham (CMAP, Ecole polytechnique) and D. Talay are writing the second volume of their series published by Springer on the Mathematical Foundations of Stochastic Simulations.
- In collaboration with N. Touzi (CMAP, Ecole polytechnique), D. Talay is studying stochastic differential equations involving local times with stochastic weights, and extensions of classical notions of viscosity solutions to PDEs whose differential operator has discontinuous coefficients and transmission boundary conditions.

6.2. Financial Mathematics

Participants: Mireille Bossy, Nicolas Champagnat, Madalina Deaconu, Antoine Lejay, Khaled Salhi, Denis Talay, Etienne Tanré.

6.2.1. Published works and preprints

- In collaboration with N. Maïzi (CMA - Mines Paristech) and O. Pourtallier (COPRIN team, Inria Sophia Antipolis - Méditerranée), M. Bossy studied the existence of a Nash equilibrium between electricity producers selling their production on an electricity market and buying CO2 emission allowances on an auction carbon market. The producers' strategies integrate the coupling of the two markets via the cost functions of the electricity production. The authors set out the set of Nash equilibria on the electricity market, that constitutes an equivalence class (same prices and market shares) from which they exhibit a dominant strategy. On the coupled markets, given a specific carbon market design (in terms of penalty level and allowances), they compute the bounds of the interval where carbon prices (derived from the previous dominant strategy) evolve. They specify the properties of the associated equilibria (see [30] and [14]).
- In their article [40], N. Champagnat, M. Deaconu, A. Lejay and K. Salhi have constructed a regime switching model for estimating the Value-at-Risk. This model classifies the states in crisis and steady regimes and constructs a mixture of power laws as a model for returns of financial assets.

- In collaboration with V. Reutenauer and C. Michel (CA-CIB), D. Talay and E. Tanré worked on a model in financial mathematics including bid-ask spread cost. They study the optimal strategy to hedge an interest rate swap that pays a fixed rate against a floating rate. They present a methodology using a stochastic gradient algorithm to optimize strategies. A paper has been submitted [39].

6.2.2. Other works in progress

- In collaboration with J. Bion-Nadal (Ecole Polytechnique and CNRS), D. Talay pursued the study of a new calibration methodology based on dynamical risk measures and stochastic control PDEs.