



RESEARCH CENTER  
**Sophia Antipolis - Méditerranée**

FIELD

Activity Report 2016

**Section Software**

Edition: 2017-08-25



1. ABS Project-Team	4
2. ACUMES Project-Team	6
3. AOSTE Project-Team	7
4. APICS Project-Team (section wide)	11
5. AROMATH Project-Team	12
6. ASCLEPIOS Project-Team	13
7. ATHENA Project-Team	15
8. AYIN Team	18
9. BIOCORE Project-Team	19
10. BIOVISION Team	20
11. CAMIN Team	22
12. CASTOR Project-Team	27
13. COATI Project-Team	30
14. COFFEE Project-Team	32
15. DATASHAPE Team	33
16. DIANA Project-Team	34
17. ECUADOR Project-Team	37
18. FOCUS Project-Team	38
19. GRAPHDECO Project-Team	42
20. GRAPHIK Project-Team	43
21. HEPHAISTOS Project-Team	45
22. INDES Project-Team	47
23. LAGADIC Project-Team	48
24. LEMON Team	58
25. MAESTRO Project-Team	61
26. MARELLE Project-Team	62
27. MATHNEURO Team	64
28. MCTAO Project-Team	65
29. MORPHEME Project-Team	66
30. NACHOS Project-Team	67
31. STARS Project-Team	68
32. TITANE Project-Team	72
33. TOSCA Project-Team	74
34. VIRTUAL PLANTS Project-Team	75
35. WIMMICS Project-Team	78
36. ZENITH Project-Team	80

## ABS Project-Team

# 5. New Software and Platforms

## 5.1. The Structural Bioinformatics Library

### 5.1.1. The SBL : overview

The SBL (<http://sbl.inria.fr>) is a generic C++/python library providing algorithms and applications to solve complex problems in computational structural biology (CSB). [20].

For Biologists, the key advantages are:

- comprehensive in silico environment providing software applications,
- answering complex bio-physical problems (modeling interfaces and contacts, modeling the flexibility of proteins, and modeling macro-molecular assemblies),
- in a robust, fast and reproducible way.

For Developers, the striking facts are:

- broad C++/python toolbox,
- with modular design and careful specifications,
- fostering the development of complex applications.

### 5.1.2. The SBL : rationale and design

Software development generally faces a dichotomy, with on the one hand generic libraries providing methods of ubiquitous interest, and on the other hand application driven libraries targeting specific application areas. Libraries in the former category typically provide state-of-the art low level algorithms carefully specified, at the detriment of high level applications. Libraries in the latter category are generally high level and user-friendly, but the lack of formalism often makes it difficult to couple them to low level algorithms with formal specifications. The SBL ambitions to reconcile both software development philosophies, based on an advanced design suited for all classes of users and developers.

In terms of high-level operations, the SBL provides various applications revolving around the problem of understanding the relationship between the structure and the function of macro-molecules and their complexes (see below). In terms of low-level operations, the design of the SBL is meant to accommodate both the variety of models coding the physical and chemical properties of macro-molecular systems (models based on unions of balls such as van der Waals models or solvent accessible models, or models based on conformations and conformational ensembles), as well as the variety of operations (geometric, topological, and combinatorial) undertaken on these models.

More precisely, the SBL consists of the following software components, detailed below:

- **SBL-APPLICATIONS:** high level applications solving specific applied problems.
- **SBL-CORE:** low-level generic C++ classes templated by traits classes specifying C++ concepts<sup>0</sup>.
- **SBL-MODELS:** C++ *models* matching the C++ concepts required to instantiate classes from SBL-CORE.
- **SBL-MODULES:** C++ classes instantiating classes from the SBL-CORE with specific biophysical models from SBL-MODELS. A module may be seen as a black box transforming an input into an output. With modules, an application workflow consists of interconnected modules.

---

<sup>0</sup>The design has been guided by that used in the Computational Geometry Algorithm Library (CGAL), see <http://www.cgal.org>

### 5.1.3. The SBL for end-users: SBL-APPLICATIONS

End users will find in the SBL portable applications running on all platforms (Linux, MacOS, Windows). These applications split into the following categories:

- **Space Filling Models:** applications dealing with molecular models defined by unions of balls.
- **Conformational Analysis:** applications dealing with molecular flexibility.
- **Large assemblies:** applications dealing with macro-molecular assemblies involving from tens to hundreds of macro-molecules.
- **Data Analysis:** applications providing novel data analysis - statistical analysis tools.
- **Data Management:** applications to handle input data and results, using standard tools revolving around the XML file format (in particular the XPath query language). These tools allow automating data storage, parsing and retrieval, so that upon running calculations with applications, statistical analysis and plots are a handful of python lines away.

### 5.1.4. The SBL for developers: SBL-CORE, SBL-MODELS and SBL-MODULES

The SBL makes it easy to develop novel high-level applications, by providing high level ready to use C++ classes instantiating various biophysical models.

In particular, modules allow the development of applications without the burden of instantiating low level classes. In fact, once modules are available, designing an application merely consists of connecting modules.

### 5.1.5. The SBL for low-level developers and contributors: SBL-CORE, and SBL-MODELS

Low level developments may use classes from / contribute classes to SBL-CORE and SBL-MODELS. In fact, such developments are equivalent to those based upon C++ libraries such as CGAL (<http://www.cgal.org/>) or boost C++ libraries (<http://www.boost.org/>). It should be noticed that the SBL heavily relies on these libraries. The SBL-CORE is organized into four sub-sections:

- CADS : Combinatorial Algorithms and Data Structures.
- GT : Computational geometry and computational topology.
- CSB : Computational Structural Biology.
- IO : Input / Output.

It should also be stressed that these packages implement algorithms not available elsewhere, or available in a non-generic guise. Due to the modular structure of the library, should valuable implementations be made available outside the SBL (e.g. in CGAL or boost), a substitution may occur.

### 5.1.6. Interoperability

The SBL is interoperable with existing molecular modeling systems, at several levels:

- At the library level, our state-of-the-art algorithms (e.g. the computation of molecular surfaces and volumes) can be integrated within existing software by instantiating the required classes from SBL-CORE, or using the adequate modules.
- At the application level, our applications can easily be integrated within processing pipelines, since the format used for input and output are standard ones. (For input, the PDB format can always be used. For output, our applications generate XML files.)
- Finally, for visualization purposes, our applications generate outputs for the two reference molecular modeling environments, namely Visual Molecular Dynamics (<http://www.ks.uiuc.edu/Research/vmd/>) and Pymol (<http://www.pymol.org/>).

### 5.1.7. Releases, distribution, and license

The SBL is released under a proprietary open source license, see <http://sbl.inria.fr/license/>.

The source code is distributed from <http://sbl.inria.fr>, using tarballs and a git repository. Bugzilla is used to handle user's feedback and bug tracking.

## **ACUMES Project-Team**

# **6. New Software and Platforms**

## **6.1. BuildingSmart**

BuildingSmart interactive visualization

KEYWORDS: Physical simulation - 3D rendering - 3D interaction

- Contact: Abderrahmane Habbal

The aim of the BuildingSmart project is to develop a software environment for the simulation and interactive visualisation for the design of buildings (structural safety, thermal confort). The software is to be integrated in an immersive space (<https://www.youtube.com/watch?v=wAm7faixBak>) The project is hosted by the ACUMES project-team in collaboration with the SED service (Service d'Expérimentation et de Développement) and Experts from ArcelorMittal Construction. The project is financed by an Inria ADT which recruited an experienced engineer (starting in december 2015), whose main task is to study and develop solutions dedicated to interactive visualisation of building performances (heat, structural) in relation to the Building Information Modeling BIM framework.

## AOSTE Project-Team

# 5. New Software and Platforms

## 5.1. EVT Kopernic

Extreme Value Theory for Keeping Worst Reasoning Appropriate for Different Criticalities

**FUNCTIONAL DESCRIPTION** This software provides a probabilistic bound on the worst case execution time of a program. Its third version, released in March 2016, covers the case of statistically dependent execution times. Currently integrated in Rapitime (Rapita tool chain), a lighter version is under preparation for integration in FUI Waruna framework as well as in the preparation of hybrid versions to be released in 2017 as output of Capacites project.

- Participants: Liliana Cucu and Adriana Gogonel
- Contact: Liliana Cucu
- URL: <https://who.rocq.inria.fr/Liliana.Cucu/Software.html>

## 5.2. KPASSA

K-Periodic Asap Static Schedule Analyser

**FUNCTIONAL DESCRIPTION** This software is dedicated to the simulation, analysis, and static scheduling of Event/Marked Graphs, SDF and KRG extensions. A graphical interface allows to edit the Process Networks and their time annotations (latency, ...). Symbolic simulation and graph-theoretic analysis methods allow to compute and optimize static schedules, with best throughputs and minimal buffer sizes. In the case of KRG the (ultimately k-periodic) routing patterns can also be provided and transformed for optimal combination of switching and scheduling when channels are shared. KPASSA also allows for import/export of specific description formats such as UML-MARTE, to and from our other TimeSquare tool.

- Participants: Jean Vivien Millo and Robert De Simone
- Contact: Robert de Simone
- URL: <http://www-sop.inria.fr/members/Jean-Vivien.Millo/kpassa/index.php>

## 5.3. Lopht

Logical to Physical Time Compiler

**SCIENTIFIC DESCRIPTION** Lopht is a system-level compiler for embedded systems. Its input is formed of three objects:

- A functional specification in a high-level synchronous language.
- A description of the implementation platform, defining the topology of the parallel execution platform, and the capacity of its elements.
- A set of non-functional requirements, provided under the form of annotations on both functional specification and platform description.

The algorithmic core of Lopht is formed of allocation and scheduling heuristics which rely on two fundamental choices: the use of table-based static scheduling and the use of low-complexity heuristics based on list scheduling. The output of Lopht is formed of all the C code and configuration information needed to allow real deployment on the physical target platform.

**FUNCTIONAL DESCRIPTION** Accepted input languages for functional specifications include Heptagon and Scade v4. Lopht uses as front-end a modified version of the Heptagon compiler developed at Inria. The use of this front-end also allows the use of legacy/business C code satisfying the Heptagon calling convention.

Regarding scheduling, the originality of Lopht resides in a strong focus on classical compiler optimizations e.g. software pipelining), on novel architectural targets (many-core chips and time-triggered embedded systems), and the possibility to handle multiple, complex non-functional requirements covering real-time (release dates and deadlines possibly larger than the period, end-to-end flow constraints), ARINC 653 partitioning, the possibility to preempt or not each task, and allocation.

The output of Lopht is formed of all the C code and configuration information needed to allow compilation, linking/loading, and real-time execution on the target platform. Lopht fully automates the creation of tasks, partition, the full synthesis of C code compliant with the target API (e.g. C/APEX for ARINC 653 platforms), including communication code, and OS configuration for each computer), as well as the synthesis of communication schedules for the system

Two Lopht back-ends provide distinct input languages for platform description:

- One for distributed time-triggered architectures using ARINC 653-based processing nodes (SBCs) and Time-Triggered Ethernet networks
- One for many-core processors with support with timing predictability.

An ongoing research effort aims at providing a unified, formal platform description language allowing the unification of these back-ends.

- Participants: Dumitru Potop Butucaru, Raul Gorcitz, and Keryan Didier
- Contact: Dumitru Potop Butucaru

## 5.4. SAS

Simulation and Analysis of Scheduling

SCIENTIFIC DESCRIPTION The SAS (Simulation and Analysis of Scheduling) software allows the user to perform the schedulability analysis of periodic task systems in the monoprocessor case.

The main contribution of SAS, when compared to other commercial and academic softwares of the same kind, is that it takes into account the exact preemption cost between tasks during the schedulability analysis. Beside usual real-time constraints (precedence, strict periodicity, latency, etc.) and fixed-priority scheduling policies (Rate Monotonic, Deadline Monotonic, Audsley++, User priorities), SAS additionally allows to select dynamic scheduling policy algorithms such as Earliest Deadline First (EDF). The resulting schedule is displayed as a typical Gantt chart with a transient and a permanent phase, or as a disk shape called "dameid", which clearly highlights the idle slots of the processor in the permanent phase.

FUNCTIONAL DESCRIPTION The SAS software allows the user to perform the schedulability analysis of periodic task systems in the monoprocessor case.

- Participants: Daniel De Rauglaudre and Yves Sorel
- Contact: Yves Sorel
- URL: <http://pauillac.inria.fr/~ddr/sas-dameid/>

## 5.5. SynDEx

KEYWORDS: Embedded systems - Real time - Optimization - Distributed - Scheduling analyses

SCIENTIFIC DESCRIPTION SynDEx is a system level CAD software implementing the AAA methodology for rapid prototyping and for optimizing distributed real-time embedded applications. It is developed in OCaml.

Architectures are represented as graphical block diagrams composed of programmable (processors) and non-programmable (ASIC, FPGA) computing components, interconnected by communication media (shared memories, links and busses for message passing). In order to deal with heterogeneous architectures it may feature several components of the same kind but with different characteristics.



Two types of non-functional properties can be specified for each task of the algorithm graph. First, a period that does not depend on the hardware architecture. Second, real-time features that depend on the different types of hardware components, ranging amongst execution and data transfer time, memory, etc.. Requirements are generally constraints on deadline equal to period, latency between any pair of tasks in the algorithm graph, dependence between tasks, etc.

Exploration of alternative allocations of the algorithm onto the architecture may be performed manually and/or automatically. The latter is achieved by performing real-time multiprocessor schedulability analyses and optimization heuristics based on the minimization of temporal or resource criteria. For example while satisfying deadline and latency constraints they can minimize the total execution time (makespan) of the application onto the given architecture, as well as the amount of memory. The results of each exploration is visualized as timing diagrams simulating the distributed real-time implementation.

Finally, real-time distributed embedded code can be automatically generated for dedicated distributed real-time executives, possibly calling services of resident real-time operating systems such as Linux/RTAI or Osek for instance. These executives are deadlock-free, based on off-line scheduling policies. Dedicated executives induce minimal overhead, and are built from processor-dependent executive kernels. To this date, executive kernels are provided for: TMS320C40, PIC18F2680, i80386, MC68332, MPC555, i80C196 and Unix/Linux workstations. Executive kernels for other processors can be achieved at reasonable cost following these examples as patterns.

**FUNCTIONAL DESCRIPTION** Software for optimising the implementation of embedded distributed real-time applications and generating efficient and correct by construction code

- Participants: Yves Sorel and Meriem Zidouni
- URL: <http://www.syndex.org>

## 5.6. TimeSquare

**KEYWORDS:** Profil MARTE - Embedded systems - UML - IDM

**SCIENTIFIC DESCRIPTION** TimeSquare offers six main functionalities:

- graphical and/or textual interactive specification of logical clocks and relative constraints between them,
- definition and handling of user-defined clock constraint libraries,
- automated simulation of concurrent behavior traces respecting such constraints, using a Boolean solver for consistent trace extraction,
- call-back mechanisms for the traceability of results (animation of models, display and interaction with waveform representations, generation of sequence diagrams...).
- compilation to pure java code to enable embedding in non eclipse applications or to be integrated as a time and concurrency solver within an existing tool.
- a generation of the whole state space of a specification (if finite of course) in order to enable model checking of temporal properties on it

**FUNCTIONAL DESCRIPTION** TimeSquare is a software environment for the modeling and analysis of timing constraints in embedded systems. It relies specifically on the Time Model of the Marte UML profile, and more accurately on the associated Clock Constraint Specification Language (CCSL) for the expression of timing constraints.

- Participants: Frederic Mallet, and Julien Deantoni
- Contact: Frederic Mallet
- URL: <http://timesquare.inria.fr>

## 5.7. Vercors

### KEYWORD:

- Participants: Eric Madelaine, Oleksandra Kulankhina, Jimmy Awk, Xudong Qin
- Contact: Eric Madelaine
- URL: <http://www-sop.inria.fr/oasis/Vercors>

**FUNCTIONAL DESCRIPTION** The Vercors tools include front-ends for specifying the architecture and behaviour of components in the form of UML diagrams. We translate these high-level specifications, into behavioural models in various formats, and we also transform these models using abstractions. In a final step, abstract models are translated into the input format for various verification toolsets. Currently we mainly use the various analysis modules of the CADP toolset.

We have achieved this year a major version of the platform frontend, named VCE-v4, that is now distributed on our website, and used by some of our partners. This version features a full chain of tools from the design of systems in the graphical component editors (VCE), the checking of static semantics correctness, the generation of a semantic model suitable for model-checking, and finally the generation of executable code for the Proactive/GCM platform. These new features, and the tool architecture, have been described in [29] and [18].

**APICS Project-Team (section vide)**

## AROMATH Project-Team

# 5. New Software and Platforms

## 5.1. AXEL

KEYWORDS: CAO - Algebraic geometric modeler

SCIENTIFIC DESCRIPTION

Axel is an algebraic geometric modeler that aims at providing “algebraic modeling” tools for the manipulation and computation with curves, surfaces or volumes described by semi-algebraic representations. These include parametric and implicit representations of geometric objects. Axel also provides algorithms to compute intersection points or curves, singularities of algebraic curves or surfaces, certified topology of curves and surfaces, etc. A plugin mechanism allows to extend easily the data types and functions available in the platform.

FUNCTIONAL DESCRIPTION

Axel is a cross platform software to visualize, manipulate and compute 3D objects. It is composed of a main application and several plugins. The main application provides atomic geometric data and processes, a viewer based on VTK, a GUI to handle objects, to select data, to apply process on them and to visualize the results. The plugins provides more data with their reader, writer, converter and interactors, more processes on the new or atomic data. It is written in C++ and thanks to a wrapping system using SWIG, its data structures and algorithms can be integrated into C# programs, as well as Python. The software is distributed as a source package, as well as binary packages for Linux, MacOSX and Windows.

- Participants: Nicolas Douillet, Anaïs Ducoffe, Valentin Michelet, Bernard Mourrain, Meriadeg Perrinel, Stéphane Chau and Julien Wintz
- Contact: Bernard Mourrain
- URL: <http://axel.inria.fr/>

Collaboration with Elisa Berrini (MyCFD, Sophia), Tor Dokken (Gotools library, Oslo, Norway), Angelos Mantzaflaris (GISMO library, Linz, Austria), Laura Saini (Post-Doc GALAAD/Missler, TopSolid), Gang Xu (Hangzhou Dianzi University, China).

## ASCLEPIOS Project-Team

### 5. New Software and Platforms

#### 5.1. LSVF

KEYWORDS: Health - Brain - Medical Image Processing - Medical Imaging

FUNCTIONAL DESCRIPTION:

The Longitudinal Stationary Velocity Fields Framework is a set of tools based on the SVF parameterization of diffeomorphic deformations that allows a new type of longitudinal deformation-based morphometric analyses. The framework comprises tools to compute the deformation encoded by the exponential of an SVF, the log-demons registration software and the Pole ladder, an algorithm to parallel transport deformation trajectories. These tools can be organized in a Longitudinal Log-Demons Pipeline (LLDP), to estimate the longitudinal brain deformations from image data series, transport them in a common space and perform statistical groupwise analyses.

Sources are available under custom licence.

- Participants: Mehdi Hadj-Hamou, Marco Lorenzi and Xavier Pennec
- Contact: Xavier Pennec
- URL: <http://team.inria.fr/asclepios/software/stationary-velocity-field-tools/>
- URL: <http://team.inria.fr/asclepios/software/lclogdemons/>

#### 5.2. medInria

KEYWORDS: Segmentation - Health - DWI - Visualization - Medical Imaging

SCIENTIFIC DESCRIPTION

It aims at creating an easily extensible platform for the distribution of research algorithms developed at Inria for medical image processing. This project has been funded by the D2T (ADT MedInria-NT) in 2010 and renewed in 2012. The Visages team leads this Inria national project and participates in the development of the common core architecture and features of the software as well as in the development of specific plugins for the team's algorithm.

FUNCTIONAL DESCRIPTION

MedInria is a free software platform dedicated to medical data visualization and processing.

- Participants: Jaime Garcia Guevara, Theodore Papadopoulo, Olivier Commowick, Rene-Paul Debroize, Guillaume Pasquier, Laurence Catanese, Olivier Commowick, Alexandre Abadie, Benoit Bleuze, Clement Philipot, Fatih Arslan, Florian Vichot, John Stark, Julien Wintz, Loïc Cadour, Maxime Sermesant, Michael Knopke, Nicolas Toussaint, Olivier Clatz, Pierre Fillard, Sergio Medina, Stephan Schmitt and Hakim Fadil
- Partners: HARVARD Medical School - IHU LIRYC - King's College London - UPF Barcelona - NIH
- Contact: Olivier Commowick
- URL: <http://med.inria.fr>

#### 5.3. MUSIC

Multi-modality Platform for Specific Imaging in Cardiology

KEYWORDS: Health - Cardiac - Computer-assisted interventions - Cardiac Electrophysiology - Medical imaging

#### FUNCTIONAL DESCRIPTION

MUSIC is a software developed by the Asclepios research project in close collaboration with the IHU LIRYC in order to propose functionalities dedicated to cardiac interventional planning and guidance. This includes specific tools (algorithms of segmentation, registration, etc.) as well as pipelines. The software is based on the MedInria platform.

- Participants: Loïc Cadour, Maxime Sermesant, Florian Vichot, Hakim Fadil, Florent Collot and Mathilde Merle
- Contact: Maxime Sermesant
- URL: <https://team.inria.fr/asclepios/software/music/>

## 5.4. SOFA

Simulation Open Framework Architecture

KEYWORDS: Physical simulation - Health - Biomechanics - GPU - Computer-assisted surgery

#### FUNCTIONAL DESCRIPTION

SOFA is an Open Source framework primarily targeted at real-time simulation, with an emphasis on medical simulation. It is mostly intended for the research community to help develop new algorithms, but can also be used as an efficient prototyping tool. Based on an advanced software architecture, it allows : the creation of complex and evolving simulations by combining new algorithms with algorithms already included in SOFA, the modification of most parameters of the simulation (deformable behavior, surface representation, solver, constraints, collision algorithm, etc. ) by simply editing an XML file, the building of complex models from simpler ones using a scene-graph description, the efficient simulation of the dynamics of interacting objects using abstract equation solvers, the reuse and easy comparison of a variety of available methods.

A software consortium around SOFA is currently being set up to strengthen the perenial developement of the plateform <https://www.sofa-framework.org/consortium/>. The software is available under the LGPL licence.

- Participants: Chloé Audigier, Sophie Giffard-Roisin, Qiao Zheng, Roch-Philippe Molléro and Hervé Delingette
- Contact: Hervé Delingette
- URL: <http://www.sofa-framework.org>

## 5.5. VP2HF

Virtual Physiological Human for Heart Failure Platform

KEYWORDS: Health - Cardiac - Medical - Image - Processing - Medical imaging

#### FUNCTIONAL DESCRIPTION

The VP2HF software is developed by the Asclepios team and brings together all the research produced by the VP2HF's partners. It contains MedInria plugins implemented by teams such as UPF Barcelona, KCL, and specific tools provided by Philips (algorithms of segmentation, scar segmentation, ...). It aims at integrating in a single clinical workflow, tools to improve the therapy selection and treatment optimisation for patients suffering from heart failure.

- Participants: Maxime Sermesant, Hakim Fadil and Loïc Cadour
- Contact: Maxime Sermesant
- URL: <http://www.vp2hf.eu>

## ATHENA Project-Team

# 6. New Software and Platforms

## 6.1. Coadapt P300 Stimulator

KEYWORDS: Health - Brain-Computer Interface

FUNCTIONAL DESCRIPTION

In the domain of Brain Computer Interfaces, extracting relevant features requires a precise timing of all events occurring in the system. In particular, when dealing with evoked responses as in the P300 speller, the timing of the visual stimulations must be well controlled. To alleviate some timing issues with the P300 speller initially provided with OpenViBE, we have implemented an external visual stimulator that allows to flash the visual targets, in a time-robust manner. In 2016 a new generation of this software has been coded, which will be released publicly in 2017. It is being tested outside of Inria by a few beta-testers.

- Participants: Nathanaël Foy, Dieter Devlaminck, Loic Mahe, Maureen Clerc, Théodore Papadopoulo, Emmanuel Maby and Jérémie Mattout
- Partner: INSERM
- Contact: Maureen Clerc
- <http://openvibe.inria.fr/coadapt-p300-stimulator-tutorial/>

## 6.2. DIPY

Diffusion Imaging in Python

KEYWORDS: MRI - Medical imaging

FUNCTIONAL DESCRIPTION

Dipy is a free and open source software project focusing mainly on diffusion magnetic resonance imaging (dMRI) analysis. Nonetheless, as we solve problems in dMRI some of the solutions are applicable to the greater medical imaging and image processing communities. See for example our registration and denoising tutorials.

- Participants: Demian Wassermann and Rutger Fick
- Contact: Demian Wassermann
- URL: <http://nipy.org/dipy/>

## 6.3. The White Matter Query Language

KEYWORDS: Neuroanatomy - Diffusion MRI - Automatic Segmentation - DSL

FUNCTIONAL DESCRIPTION The White Matter Query Language (WMQL) is a technique to formally describe white matter tracts and to automatically extract them from diffusion MRI volumes. This query language allows us to construct a dictionary of anatomical definitions describing white matter tracts. The definitions include adjacent gray and white matter regions, and rules for spatial relations. This enables the encoding of anatomical knowledge of the human brain white matter as well as the automated coherent labeling of white matter anatomy across subjects.

- Participants: Demian Wassermann
- Contact: Demian Wassermann
- URL: <http://tract-querier.readthedocs.org/en/latest/>

## 6.4. FindSources3D

KEYWORDS: Health - Neuroimaging - Visualization - Medical - Image - Processing

## FUNCTIONAL DESCRIPTION

FindSources3D is a Matlab software program dedicated to the resolution of inverse source problems in electroencephalography (EEG). From pointwise measurements of the electric potential, numerically obtained or taken by electrodes on the scalp, FindSources3D estimates pointwise dipolar current sources within the brain.

- Participants: Juliette Leblond, Maureen Clerc, Théodore Papadopoulo and Jean Paul Marmorat
- Contact: Juliette Leblond
- URL: <http://www-sop.inria.fr/apics/FindSources3D/en/index.html>

## 6.5. High Performance Diffusion MRI

KEYWORDS: Health - Neuroimaging - Medical imaging

## FUNCTIONAL DESCRIPTION

We have been closely involved in pushing the frontiers of the diffusion MRI (dMRI) in the recent years, especially in the mathematical modelling and processing of the dMRI signal and have developed state-of-the-art software implementations in the form of a C++ library that can be effectively used to infer the complex microstructure of the cerebral white matter. These algorithms and software fall into four categories : (i) local tissue modelling, which includes both popular 2nd order models and advanced higher than 2nd order models such as DTI, higher order Cartesian tensors (HOTs), ODF, FOD, EAP, maxima extraction, regularization and segmentation, (ii) generation of scalar indices (or biomarkers), which include DTI biomarkers, Diffusion Kurtosis Imaging (DKI) and invariants of 4th order tensors, (iii) global structure estimation, which includes deterministic and probabilistic tractography, and (iv) data visualisation for scalar indices, local models and global structures. This library has been transferred to the Company *Olea Medical*, where it will be at the heart of the new dMRI module to be included in the *Olea Sphere* platform.

- Participants: Aurobrata Ghosh, Théodore Papadopoulo, Rachid Deriche and Demian Wassermann
- Contact: Rachid Deriche

## 6.6. MedInria

KEYWORDS: Segmentation - Health - DWI - Visualization - Medical imaging

## SCIENTIFIC DESCRIPTION

It aims at creating an easily extensible platform for the distribution of research algorithms developed at Inria for medical image processing. This project has been funded by the D2T (ADT MedInria-NT) in 2010 and renewed in 2012. The Visages team leads this Inria national project and participates in the development of the common core architecture and features of the software as well as in the development of specific plugins for the team's algorithm.

## FUNCTIONAL DESCRIPTION

MedInria is a free software platform dedicated to medical data visualization and processing.

- Participants: Jaime Garcia Guevara, Théodore Papadopoulo, Olivier Commowick, Rene-Paul Debroize, Guillaume Pasquier, Laurence Catanese, Olivier Commowick, Alexandre Abadie, Benoit Bleuze, Clement Philipot, Fatih Arslan, Florian Vichot, John Stark, Julien Wintz, Loïc Cadour, Maxime Sermesant, Michael Knopke, Nicolas Toussaint, Olivier Clatz, Pierre Fillard, Sergio Medina, Stephan Schmitt and Hakim Fadil
- Partners: HARVARD Medical School - IHU - LIRYC - IHU - Strasbourg - NIH
- Contact: Olivier Commowick
- URL: <http://med.inria.fr>

## 6.7. OpenMEEG

KEYWORDS: Health - Neuroimaging - Medical imaging



**FUNCTIONAL DESCRIPTION**

OpenMEEG provides state-of-the art tools for processing EEG and MEG data. It incorporates a newly proposed, symmetric BEM for the forward problem, and a distributed source inverse problem, with three different types of regularizations, two of which are original, based on norms of the surface gradient of the source distribution. OpenMEEG is a free, open software written in C++, and can be accessed either through a command line interface or through a user-friendly interface. OpenMEEG is being used for functional neuroimaging, through third-party software (Brainstorm and Fieldtrip), as can be noticed by the citations to our articles [9] and [89].

- Participants: Théodore Papadopoulo, Maureen Clerc, Alexandre Gramfort, Emmanuel Olivi, Kai Dang, Geoffroy Adde, Perrine Landreau, Renaud Keriven and Jan Kybic
- Contact: Théodore Papadopoulo
- URL: <http://openmeeg.github.io/>

## 6.8. OpenViBE

**KEYWORDS:** Neurosciences - Interaction - Virtual reality - Health - Real time - Neurofeedback - Brain-Computer Interface - EEG - 3D interaction

**FUNCTIONAL DESCRIPTION**

OpenViBE is a software platform for real-time neurosciences (that is, for real-time processing of brain signals). It can be used to acquire, filter, process, classify and visualize brain signals in real time from various signal sources. OpenViBE is free and open source software. It works on Windows and Linux operating systems.

- Participants: Yann Renard, Anatole Lécuyer, Fabien Lotte, Bruno Renier, Vincent Delannoy, Laurent Bonnet, Baptiste Payan, Jozef Legeny, Jussi Tapio Lindgren, Alison Cellard, Loic Mahe, Guillaume Serriere, Marsel Mano, Maureen Clerc, Théodore Papadopoulo, Laurent Bougrain, Jeremy Frey and Nathanaël Foy
- Partners: CEA-List - GIPSA-Lab - INSERM
- Contact: Anatole Lécuyer
- URL: <http://openvibe.inria.fr>

## **AYIN Team**

# **5. New Software and Platforms**

## **5.1. Consulting for Industry**

Josiane Zerubia is a scientific consultant for the Galderma company (<http://www.galderma.com/AboutGalderma/Worldwide-presence/R-D-Locations>)

## BIOCORE Project-Team

# 6. New Software and Platforms

## 6.1. In@lgae

Numerical simulator of microalgae based processes

KEYWORDS: Simulation - Microalgae system - Productivity

FUNCTIONAL DESCRIPTION

In@lgae simulates the productivity of a microalgae production system, taking into account both the process type and its location and time of the year. The process is mainly defined by its thermal dynamics and by its associated hydrodynamics. For a given microalgal strain, a set of biological parameters describe the response to nitrogen limitation, temperature and light. As a result, the biomass production, CO<sub>2</sub> and nitrogen fluxes, lipid and sugar accumulation are predicted.

- Participants: Étienne Delclaux, Francis Mairet, Quentin Béchet and Olivier Bernard
- Contact: Olivier Bernard

## 6.2. Odin

Platform for advanced monitoring, control and optimisation of bioprocesses

KEYWORDS: Bioinformatics - Biotechnology

SCIENTIFIC DESCRIPTION

This C++ application enables researchers and industrials to easily develop and deploy advanced control algorithms through the use of a Scilab interpreter. It also contains a Scilab-based process simulator which can be harnessed for experimentation and training purposes. ODIN is primarily developed in the C++ programming language and uses CORBA to define component interfaces and provide component isolation. ODIN is a distributed platform, enabling remote monitoring of the controlled processes as well as remote data acquisition. It is very modular in order to adapt to any plant and to run most of the algorithms, and it can handle the high level of uncertainties that characterises the biological processes through explicit management of confidence indexes.

FUNCTIONAL DESCRIPTION

ODIN is a software framework for bioprocess control and supervision. ODIN is a distributed platform, where algorithms are described with a common structure easy to implement. Finally, ODIN can perform remote data acquisition and process these data to compute the signals to be applied to the actuators, together with estimates of state variables or process state. ODIN can handle the high level of uncertainties that characterises the biological processes through explicit management of confidence indexes.

- Participants: Melaine Gautier, Florian Guenn, Fabien Dilet, Olivier Calabro, Romain Primet, Serigne Sow, Olivier Bernard, Mathieu Lacage and Francesco Novellis
- Contact: Olivier Bernard
- URL: <https://team.inria.fr/biocore/software/odin/>

## BIOVISION Team

# 5. New Software and Platforms

## 5.1. Virtual Retina: A biological retina model with contrast gain control for large scale simulations

KEYWORDS: Neurosciences - Simulation - Biology - Health

SCIENTIFIC DESCRIPTION

The Virtual Retina software allows large-scale simulations of biologically-plausible retinas, with customizable parameters. Virtual Retina has been shown to reproduce a wide range of experimental data from salamander, cat and primate retinas [14], and has been used in several theoretical studies [65], [66], [67], [41], [17]. It has recently been shown to predict spikes in a mouse retina more accurately than linear-nonlinear (LN) models [79]. The underlying model includes a non-separable spatio-temporal linear model of filtering in the Outer Plexiform Layer, a shunting feedback at the level of bipolar cells, and a spike generation process using noisy leaky integrate-and-fire neurons to model RGCs. All parameters for the different stages of the model are customizable so that the visual field can be paved with different RGC types.

FUNCTIONAL DESCRIPTION.

Virtual Retina is a simulation software that allows large-scale simulations of biologically-plausible retinas.

- Participants: Bruno Cessac, Maria-Jose Escobar, Pierre Kornprobst, Selim Kraria, Daniela Pamplona, Selma Souihel, Thierry Vieville and Adrien Wohrer.
- Contact: Pierre Kornprobst
- URL: <https://enas.inria.fr/virtual-retina.html>

## 5.2. ENAS: Event Neural Assembly Simulation

KEYWORDS: Neurosciences - Health - Physiology

SCIENTIFIC DESCRIPTION

As one gains more intuitions and results on the importance of concerted activity in spike trains, models are developed to extract potential canonical principles underlying spike coding. These methods shed a new light on spike train dynamics. However, they require time and expertise to be implemented efficiently, making them hard to use in a daily basis by neuroscientists or modelers. To bridge this gap, we developed the license free multiplatform software ENAS (<https://enas.inria.fr>) integrating tools for individual and collective spike analysis and simulation, with some specificities devoted to the retina. The core of ENAS is the statistical analysis of population codes. One of its main strength is to provide statistical analysis of spike trains using Maximum Entropy-Gibbs distributions taking into account both spatial and temporal correlations as constraints, allowing to introduce causality and memory in statistics. It also generates simulated population raster from an user-specified Gibbs distribution.

We hope that ENAS will become a useful tool for neuroscientists to analyse spike trains and we hope to improve it thanks to user feedback. Our goal is to progressively enrich it with the latest research results, in order to facilitate transfer of new methods to the community.

FUNCTIONAL DESCRIPTION. ENAS is developed jointly by the Biovision, CORTEX/Mnemosyne, and DREAM Inria teams, under CeCILL-C licence, APP logiciel ENAS : IDDN.FR.OO1.190004.000.S.P.2014.000.31235. It can be freely loaded. ENAS has a friendly Graphical User Interface that avoids any scripting or writing code from user. Most methods have been implemented to run in parallel to reduce the time and memory consumption.

- Participants: Bruno Cessac, Pierre Kornprobst, Selim Kraria, Hassan Nasser, Thierry Vieville, Daniela Pamplona, Geoffrey Portelli, Selma Souihel.
- Contact: Bruno Cessac
- URL: <https://enas.inria.fr>

### **5.3. The Enas–Virtual Retina platform**

In 2016 we merged Enas and Virtual Retina to produce the Enas platform <https://enas.inria.fr>. The initial version of Virtual retina has been extended to include lateral connections in the Inner Plexiform Layer. We can then simulate the response of the retina to visual stimuli (movies), including the effect of lateral connectivity, analyse the collective spike response to this stimulus using Gibbs distributions, and reproduce a similar raster using learning methods shaping the connectivity in the Inner Plexiform Layer.

This work has been presented in [27] and submitted to Frontiers in Neuroinformatics [3].

## CAMIN Team

# 6. New Software and Platforms

## 6.1. Software and platforms

### 6.1.1. HILECOP

**Participants:** Baptiste Colombani, David Andreu, Thierry Gil [LIRMM], Robin Passama [LIRMM].

High Level hardware Component Programming

**FUNCTIONAL DESCRIPTION:** Our SENIS (Stimulation Electrique Neurale dIStribuee) based FES architecture relies on distributed stimulation units (DSU) which are interconnected by means of a 2-wire based network. A DSU is a complex digital system since it embeds among others a dedicated processor (micro-machine with a specific reduced instruction set), a monitoring module and a 3-layer protocol stack. To face the complexity of the units digital part and to ease its prototyping on programmable digital devices (e.g. FPGA), we developed an approach for high level hardware component programming (HILECOP). To support the modularity and the reusability of sub-parts of complex hardware systems, the HILECOP methodology is based on components. An HILECOP component has: a Petri Net (PN) based behavior (fig.5), a set of functions whose execution is controlled by the PN, and a set of variables and signals. Its interface contains places and transitions from which its PN model can be inter-connected as well as signals it exports or imports. The interconnection of those components, from a behavioral point of view, consists in the interconnection of places and/or transitions according to well-defined mechanisms: interconnection by means of oriented arcs or by means of the "merging" operator (existing for both places and transitions).

The Eclipse-based version of HILECOP (registered at the french Agence de Protection des Programmes (APP)) has been refactored: for instance, the application ECore model, a new Eclipse E4 architecture and a set of new features (new link types and new views to connect components) have been developed.

Undergoing work concerns the integration, in the HILECOP tool, of the formalism evolutions that allow behavior aggregation as well as exception handling, both for analysis and implementation sides.

Specification of GALS systems (Globally Asynchronous Locally Synchronous) is also an ongoing work, the aim being to take into account deployment properties like connecting different clocks to HILECOP components within a same FPGA, or on a set of interconnected FPGAs (and thus interconnecting them by means of asynchronous signals).

### 6.1.2. *PersoBalance: A Personalized Balance Assessment in Home Rehabilitation*

**Participants:** Maxime Tournier, Alejandro Gonzalez, Philippe Fraisse, Mitsuhiro Hayashibe.

In 2014-2015, the team demonstrated the feasibility of a personalized balance assessment system using low-end sensors for home rehabilitation. The corresponding software (PersoBalance) performs an identification of inertial parameters for a subject using a depth camera and a connected balance board (in this case, a Nintendo Wii BalanceBoard) through a dedicated Kalman filter as the subject assumes various body postures. When the inertial parameters are estimated, the software is then able to compute a stability index for the subject based on criteria found in robotics and biomechanics literature. This year, in order to exploit the newer, more accurate and more robust sensors such as the Microsoft Kinect v2, a new version of the PersoBalance software was engineered. While the core method remains the same, several improvements have been made regarding efficiency, user interface and extensibility. The new system is faster, more accurate and robust. It automatically registers the balance board during identification, and features improved graphical feedback during both identification and stability estimation phases. New stability measures were added, and support for online inverse dynamics is on the way. Most of the new version uses a scripting language (Python) except for time-critical algorithms, making the software easily extensible without recompilation. It is supported by Inria ADT PersoBalance2. Currently the software is being adapted to embedded computers in order to provide monitoring data in the City4Age project.

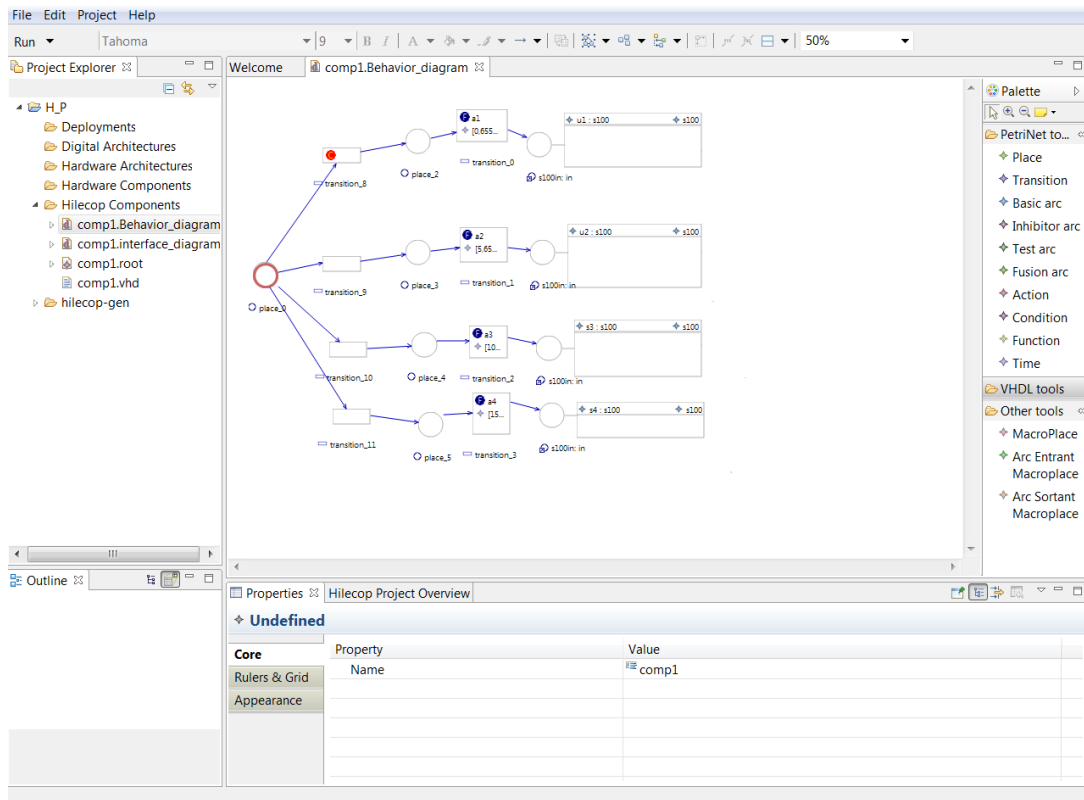

Figure 5. HILECOP screenshot

PersoBalance is registered with the Agency for the Protection of Programs (APP) and deposited at the BNF (Bibliothèque Nationale de France). Its registration number is Antepedia Deposit 20150710154654.



Figure 6. PersoBalance: Online stability estimation, from left to right: as a subject undergoes an unexpected external push, the system automatically estimates the ground reaction forces (pink arrow) and computes a stability index from the position of the ZRAM point relative to the support polygon (white/orange). The skeleton colour changes from green to red as the stability index decreases.

### 6.1.3. Sensbiotk

**Participants:** Christine Azevedo Coste, Roger Pissard-Gibollet, Benoît Sijobert.

Sensbiotk is a toolbox in Python for the calibration, the acquisition, the analysis and visualization of motion capture Inertial Measurement Units (IMU). Motion and Gait parameter reconstruction algorithms are also available.

<http://sensbio.github.io/sensbiotk/>

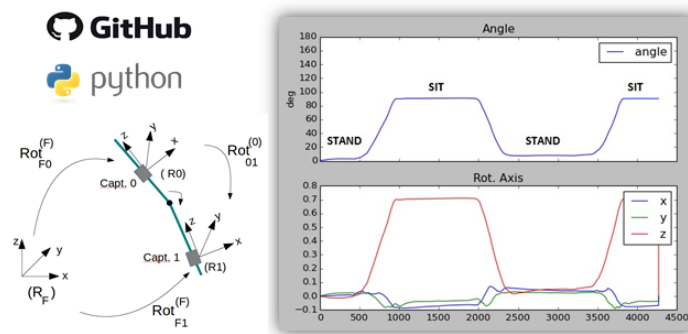

Figure 7. Sensbiotk toolbox for the calibration, the acquisition, the analysis and visualization of motion capture Inertial Measurement Units (IMU)

### 6.1.4. MOS2SENS

**Participants:** Mélissa Dali, Olivier Rossel, David Guiraud.



From Model Optimization and Simulation To Selective Electrical Neural Stimulation: it allows to manipulate 3D modeling of nerve and cuff electrodes taking into account anisotropy and the most advanced HH models of the myelinated axons. Based on optimized computing scheme, it allows to predict the activation areas induced by a complex 3D spreading of the current over a multicontact electrodes. Moreover, the tool allows for performing optimization of the needed current to target a specific cross section of the nerve. Version 1.0 (IDDN.FR.001.490036.000.S.P.2014.000.31230) has been released on december 2014 and v2.0 will be released January 2017. The last version includes full interface with OpenMEEG and COMSOL, and many other enhancements concerning both the model itself and the computation scheme.

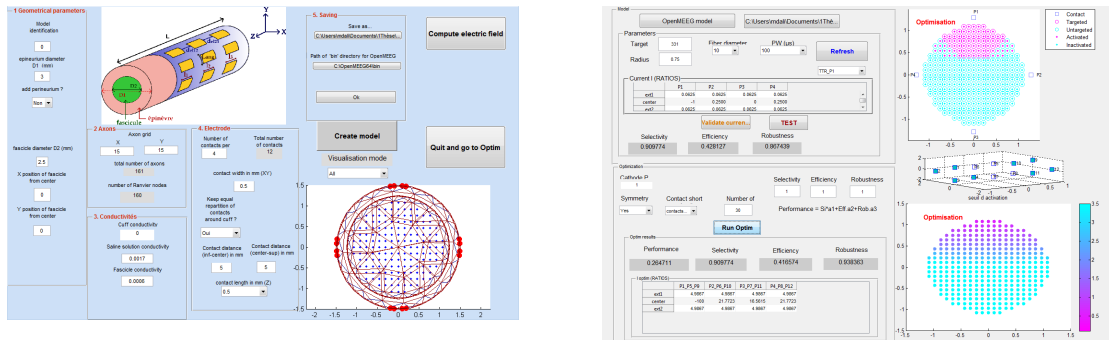

Figure 8. Graphical interface of software MOS2SENS, left: modeling multicontact CUFF electrode, right: optimization for spatial selectivity

### 6.1.5. STIMEP: An advanced real-time stimulation system based on a distributed architecture

**Participants:** Arthur Hiarrassary, David Andreu, David Guiraud, Olivier Rossel, Thomas Guiho.

The STIMEP has been developed within the EPIONE project (see section 9.3.1 ) which aims at assessing the use of invasive stimulation to relieve phantom pain. This innovative wearable stimulator allows to safely manipulate sensory afferent signals of an amputee through 4 TIME-4H intra fascicular electrodes, for a total of 56 channels.

The STIMEP is also designed to be controlled in real-time by a hand-prosthesis to generate feedback sensations; it permits as well a complex impedance follow-up.

The STIMEP is based on a distributed architecture and embeds:

- 1 x controller implemented on  $\mu\text{C}/\text{OS-II}$  RTOS exchanging data with a PC (USB) or an external device (SPI),
- 4 x neural stimulators with efficient modulation mechanisms to drive up to 4 multicontact electrodes simultaneously and independently,
- 6 x fully configurable procedures (formally modeled by Petri nets):
  - Contacts check, thresholds search, sensations characterization, therapy,
  - Real-time modulation of frequency, intensity and pulse-width,
  - Complex impedance measurement.
- 2 x smart and independent synchronization outputs,
- User and technical logs of relevant information.

The STIMEP is currently used in human trials and drives simultaneously 4 multicontact intrafascicular electrodes with real time control of the intensity, pulse-width and frequency of the stimulation to remove phantom pain and elicit very accurate sensation feedback.

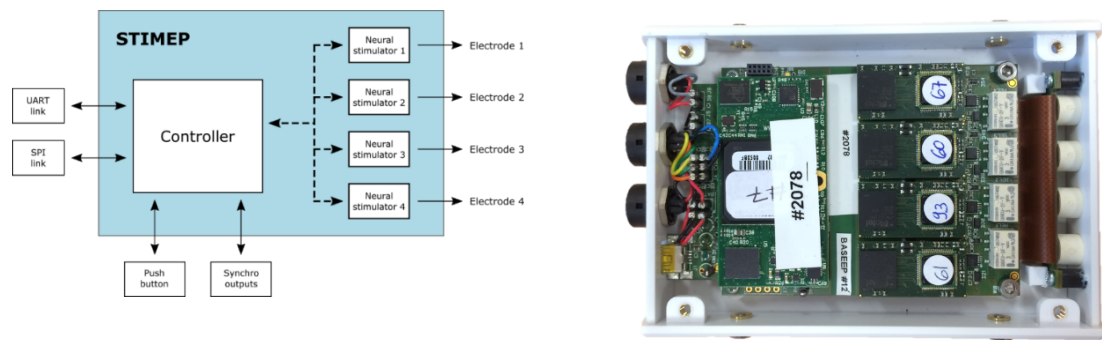

Figure 9. The STIMEP (STIMulator EPione)

## CASTOR Project-Team

# 4. New Software and Platforms

## 4.1. Equinox

### FUNCTIONAL DESCRIPTION

EQUINOX is a code dedicated to the numerical reconstruction of the equilibrium of the plasma in a Tokamak. The problem solved consists in the identification of the plasma current density, a non-linear source in the 2D Grad-Shafranov equation which governs the axisymmetric equilibrium of a plasma in a Tokamak. The experimental measurements that enable this identification are the magnetics on the vacuum vessel, but also polarimetric and interferometric measures on several chords, as well as motional Stark effect measurements. The reconstruction can be obtained in real-time and the numerical method implemented involves a finite element method, a fixed-point algorithm and a least-square optimization procedure. A deposit with APP (Agence pour la protection des programmes) has been done in 2016.

- Participants: Jacques Blum, Cedric Boulbe and Blaise Faugeras
- Contact: Blaise Faugeras

## 4.2. VacTH

### FUNCTIONAL DESCRIPTION

VacTH implements a method based on the use of toroidal harmonics and on a modelization of the poloidal field coils and divertor coils for the 2D interpolation and extrapolation of discrete magnetic measurements in a tokamak. The method is generic and can be used to provide the Cauchy boundary conditions needed as input by a fixed domain equilibrium reconstruction code like EQUINOX. It can also be used to extrapolate the magnetic measurements in order to compute the plasma boundary itself. VacTH is foreseen to be used in the real-time plasma control loop on the WEST tokamak.

- Contact: Blaise Faugeras

## 4.3. CEDRES++

### FUNCTIONAL DESCRIPTION

In Tokamaks, at the slow resistive diffusion time scale, the magnetic configuration in the plasma can be described by the MHD equilibrium equations inside the plasma and the Maxwell equations outside. Moreover, the magnetic field is often supposed not to depend on the azimuthal angle.

Under this assumption of axisymmetric configuration, the equilibrium in the whole space reduces to solving a 2D problem in which the magnetic field in the plasma is described by the well known Grad Shafranov equation. The unknown of this problem is the poloidal magnetic flux. The  $P_1$  finite element code CEDRES++ solves this free boundary equilibrium problem in direct and inverse mode and in static and evolutive formulations. The direct problem consists in the computation of the magnetic configuration and of the plasma boundary, given a plasma current density profile and the total current in each poloidal field coils (PF coils) for the static case and the voltages applied to PF supplies in the evolutive one. The aim of the inverse problem is to find currents in the PF coils in order to best fit a given plasma shape. The code is one of the free boundary codes available in the european Eurofusion - WPCD (WorkPackage Code Development for integrated modelling) platform.

- Participants: Cedric Boulbe, Jacques Blum, Blaise Faugeras and Holger Heumann
- Partners: CEA - CNRS - Université de Nice Sophia Antipolis (UNS)
- Contact: Cédric Boulbe

## 4.4. FEEQS.M

Finite Element Equilibrium Solver in MATLAB

FUNCTIONAL DESCRIPTION

FEEQS.M (Finite Element Equilibrium Solver in Matlab) is a MATLAB implementation of the numerical methods in [Heumann2015] to solve equilibrium problems for toroidal plasmas. Direct and inverse problems for both the static and transient formulations of plasma equilibrium can be solved. FEEQS.M exploits MATLAB's evolved sparse matrix methods and uses heavily the vectorization programming paradigm, which results in running times comparable to C/C++ implementations. FEEQS.M complements the production code CEDRES++ in being considered as fast prototyping test bed for computational methods for equilibrium problems. This includes aspects of numerics such as improved robustness of the Newton iterations or optimization algorithms for inverse problems (see [4]). The recent developments include:

- the comparison of FEM-BEM coupling (with B. Faugeras),
- overlapping mesh methods for free-boundary equilibrium,
- direct and inverse modes for simulations and optimal control approach to breakdown (with Eric Nardon, CEA Cadarache)
- Participant: Holger Heumann
- Contact: Holger Heumann
- URL: <https://scm.gforge.inria.fr/svn/holgerheumann/Matlab/FEEQS.M>

## 4.5. Fluidbox

FUNCTIONAL DESCRIPTION

FluidBox is a software dedicated to the simulation of inert or reactive flows. It is also able to simulate multiphase, multi-material and MDH flows. There exist 2D and 3D dimensional versions. The 2D version is used to test new ideas that are later implemented in 3D. Two classes of schemes are available : a classical finite volume scheme and the more recent residual distribution schemes. Several low Mach number preconditioning are also implemented. The code has been parallelized with and without domain overlapping.

- Participants: Remi Abgrall, Boniface Nkonga, Michael Papin and Mario Ricchiuto
- Contact: Boniface Nkonga

## 4.6. Jorek-Django

FUNCTIONAL DESCRIPTION

Jorek-Django is a new version of the JOREK software, for MHD modelling of plasma dynamic in tokamaks geometries. The numerical approximation is derived in the context of finite elements where 3D basic functions are tensor products of 2D basis functions in the poloidal plane by 1D basis functions in the toroidal direction. More specifically, Jorek uses curved bicubic isoparametric elements in 2D and a spectral decomposition (sine, cosine) in the toroidal axis. Continuity of derivatives and mesh alignment to equilibrium surface fluxes are enforced. Resulting linear systems are solved by the PASTIX software developed at Inria-Bordeaux.

- Participants: Boniface Nkonga, Hervé Guillard, Emmanuel Franck, Ayoub Iaagoubi, Ahmed Rattani
- Contact: Hervé Guillard
- URL: <https://gforge.inria.fr/projects/jorek/>

## 4.7. FBGKI

Full Braginskii

FUNCTIONAL DESCRIPTION

The Full Braginskii solver considers the equations proposed by Braginskii (1965), in order to describe the plasma turbulent transport in the edge part of tokamaks. These equations rely on a two fluid (ion - electron) description of the plasma and on the electroneutrality and electrostatic assumptions. One has then a set of 10 coupled non-linear and strongly anisotropic PDEs. FBGKI makes use in space of high order methods: Fourier in the toroidal periodic direction and spectral elements in the poloidal plane. The integration in time is based on a Strang splitting and Runge-Kutta schemes, with implicit treatment of the Lorentz terms (DIRK scheme). The spectral vanishing viscosity (SVV) technique is implemented for stabilization. Static condensation is used to reduce the computational cost. In its sequential version, a matrix free solver is used to compute the potential. The parallel version of the code is under development.

- Contact: Sebastian Minjeaud

## 4.8. PlaTo

A platform for Tokamak simulation

FUNCTIONAL DESCRIPTION

PlaTo (A platform for Tokamak simulation) is a suite of data and software dedicated to the geometry and physics of Tokamaks. Plato offers interfaces for reading and handling distributed unstructured meshes, numerical templates for parallel discretizations, interfaces for distributed matrices and linear and non-linear equation solvers. Plato provides meshes and solutions corresponding to equilibrium solutions that can be used as initial data for more complex computations as well as tools for visualization using Visit or Paraview. Plato is no more developed and is in the process of being merged with Jorek-Django

- Participants: Boniface Nkonga, Hervé Guillard, Giorgio Giorgiani, Afeintou Sangam and Elise Estivals
- Contact: Hervé Guillard

## COATI Project-Team

# 6. New Software and Platforms

## 6.1. BigGraphs

### FUNCTIONAL DESCRIPTION

The objective of BigGraphs is to provide a distributed platform for very large graphs processing. A typical data set for testing purpose is a sample of the Twitter graph : 240GB on disk, 398M vertices, 23G edges, average degree of 58 and max degree of 24635412.

We started the project in 2014 with the evaluation of existing middlewares (GraphX / Spark and Giraph / Hadoop). After having tested some useful algorithms (written according to the BSP model) we decided to develop our own platform.

This platform is based on the existing BIGGRPH library and we are now in the phasis where we focus on the quality and the improvement of the code. In particular we have designed strong test suites and some non trivial bugs have been fixed. We also have solved problems of scalability, in particular concerning the communication layer with billions of messages exchanged between BSP steps. We also have implemented specific data structures for BSP and support for distributed debugging. This comes along with the implementation of algorithms such as BFS or strongly connected components that are run on the NEF cluster.

- Participants: Luc Hogie, Nicolas Chleq, David Coudert, Michel Syska.
- Partner: This project is a joint work of the three EPI COATI, DIANA and SCALE and is supported by an ADT grant.
- Contact: Luc Hogie
- URL : <http://www.i3s.unice.fr/~hogie/biggrph/>

### ADDITIONAL SOFTWARES

The following software are useful tools that bring basic services to the platform (they are not dedicated to BIGGRPH). Participants : Luc Hogie, Nicolas Chleq

- JAC-A-BOO is a framework aiming at facilitating the deployment and the bootstrapping of distributed Java applications over Share-Nothing Clusters (SNCs). The primary motivation for developing JAC-A-BOO is to have an efficient and comprehensive deployment infrastructure for the BIGGRPH distributed graph library. <http://www.i3s.unice.fr/~hogie/jacaboo>
- LDJO (Live Distributed Java Objects) is a framework for the development and the deployment of Java distributed data structures. Alongside with data aspect of distributed data structures, LDJO comes with mechanisms for processing them in a distributed/parallel way. In particular it provides implementations of Map/Reduce and Bulk Synchronous Parallel (BSP). <http://www.i3s.unice.fr/~hogie/ldjo>
- OCTOJUS provides an object-oriented RPC (Remote Procedure Call) implementation in Java. At a higher abstraction level, OCTOJUS provides a framework for the development of systolic algorithms, a batch scheduler, as well as an implementation of Map/Reduce. The latter is used in the BIGGRPH graph computing platform. <http://www.i3s.unice.fr/~hogie/octojus>

## 6.2. GRPH

The high performance graph library for Java

### FUNCTIONAL DESCRIPTION

GRPH is an open-source Java library for the manipulation of graphs. Its main design objectives are to make it simple to use and extend, efficient, and, according to its initial motivation: useful in the context of graph experimentation and network simulation. GRPH also has the particularity to come with tools like an evolutionary computation engine, a bridge to linear solvers, a framework for distributed computing, etc.

GRPH achieves great efficiency through the use of multiple code optimization techniques such as multi-core parallelism, caching, performant data structures and use of primitive objects, interface to CPLEX linear solver, exploitation of low-level processor caches, on-the-fly compilation of specific C/C++ code, etc.

Unlike other graph libraries which impose the user to first decide if he wants to deal with directed, undirected, hyper (or not) graph, the model offered by GRPH is unified in a very general class that supports mixed graphs made of undirected and directed simple or hyper edges.

We have identified more than 600 users of GRPH since 2013. Inside Inria we collaborate with the AOSTE EPI, for example we recently added a new algorithm (proposed by N. Cohen / LRI) for iterating over the cycles of a given graph in the TimeSquare tool. We also have integrated the discrete-events simulation engine of DRMSIM and some dynamic models (evolution of the connectivity with the mobility of nodes) to GRPH. GRPH includes bridges to other graph libraries such as JUNG, JGraphT, CORESE (a software developed by the WIMMICS team Inria-I3S), LAD (C. Solnon, LIRIS), Nauty (B. D. McKay) or **Sagemath**. L. Viennot has proposed an implementation of the 4-sweep diameter algorithm designed at LIAFA .

- Participants: Luc Hogue, Nathann Cohen, David Coudert and Michel Syska.
- Contact: Luc Hogue
- URL: <http://www.i3s.unice.fr/~hogie/grph/>

### 6.3. Sagemath

SageMath

SageMath is a free open-source mathematics software system, initially created by William Stein (Professor of mathematics at Washington University), and now maintained by a large community of contributors. It builds on top of many existing open-source packages: NumPy, SciPy, matplotlib, Sympy, Maxima, GAP, FLINT, R and many more. Access their combined power through a common, Python-based language or directly via interfaces or wrappers.

We contribute the addition of new graph algorithms along with their documentations and the improvement of underlying data structures.

- Contact: David Coudert
- URL: <http://www.sagemath.org/>

## COFFEE Project-Team

### 5. New Software and Platforms

#### 5.1. APPartFlow

##### FUNCTIONAL DESCRIPTION

We are developing experimental codes, mainly based on Finite Differences, for the simulation of particulate flows. A particular attention is paid to guaranty the asymptotic properties of the scheme, with respect to relaxation parameters.

- Contact: Thierry Goudon

#### 5.2. Compass

##### FUNCTIONAL DESCRIPTION

Compass is a parallel code for the discretization of polyphasic flows by Finite Volumes methods. The code is mainly devoted to applications in porous media. It works on quite general polyhedral meshes.

- Participants: Thierry Goudon, Roland Masson, Cindy Guichard, Chang Yang and Robert Eymard
- Contact: Roland Masson
- URL: <http://math.unice.fr/~massonr/ComPASSHighEnergyGeothermy.html>

#### 5.3. NS2DDV

##### FUNCTIONAL DESCRIPTION

It is devoted to the simulation of non-homogeneous viscous flows, in two-dimensional geometries. The code is based on an original hybrid Finite Volume/Finite Element scheme, it works on unstructured meshes and can include mesh refinements strategies.

- Contact: Creusé Emmanuel
- URL: [math.univ-lille1.fr/~simpaf/SITE-NS2DDV/home.html](http://math.univ-lille1.fr/~simpaf/SITE-NS2DDV/home.html)

#### 5.4. SimBiof

##### FUNCTIONAL DESCRIPTION

We are developing numerical methods, currently by using Finite Differences approaches, for the simulation of biofilms growth. The underlying system of PDEs takes the form of multiphase flows equations with conservation constraints and vanishing phases. The numerical experiments have permitted to bring out the influence of physical parameters on the multidimensional growth dynamics.

- Contact: Thierry Goudon



## **DATASHAPE Team**

# **6. New Software and Platforms**

## **6.1. GUDHI**

Geometric Understanding in Higher Dimensions

SCIENTIFIC DESCRIPTION

The current release of the GUDHI library includes:

- Data structures to represent, construct and manipulate simplicial and cubical complexes.
- Algorithms to compute simplicial complexes from point cloud data.
- Algorithms to compute persistent homology and multi-field persistent homology.
- Simplification methods via implicit representations.

FUNCTIONAL DESCRIPTION

The GUDHI open source library will provide the central data structures and algorithms that underlie applications in geometry understanding in higher dimensions. It is intended to both help the development of new algorithmic solutions inside and outside the project, and to facilitate the transfer of results in applied fields.

- Participants: Jean-Daniel Boissonnat, Marc Glisse, Mariette Yvinec, Clément Maria, David Salinas, Paweł Dłotko, Siargey Kachanovich and Vincent Rouvreau
- Contact: Jean-Daniel Boissonnat
- URL: <http://gudhi.gforge.inria.fr/>

## DIANA Project-Team

### 5. New Software and Platforms

#### 5.1. ACQUA

**Participants:** Chadi Barakat [contact], Thierry Spetebroot, Damien Saucez.

ACQUA is an Application for prediCting Quality of User experience at Internet Access. It was supported by the French ANR CMON project on collaborative monitoring and will be supported in 2016 by both the Inria ADT ACQUA and the ANR Project BottleNet. ACQUA presents a new way for the evaluation of the performance of Internet access. Starting from network-level measurements as the ones we often do today (bandwidth, delay, loss rates, etc), ACQUA targets the estimated quality of experience related to the different applications of interest to the user without the need to run them (e.g. estimated Skype quality, estimated video streaming quality). An application in ACQUA is a function that links the network-level measurements to the expected quality of experience. In its first version (the version available online), ACQUA was concentrating on delay measurements at the access and on the detection and estimation of the impact of delay anomalies (local problems, remote problems, etc). The current work is concentrating on using the ACQUA principle in the estimation and prediction of the quality of experience of main user's applications. An Android version is under development supported by the Inria ADT ACQUA.

- URL: <http://team.inria.fr/diana/acqua/>
- Version: 1.1
- ACM: C.2.2, C.2.3
- Keywords: Internet measurement, Internet Access, Quality of Experience
- License: GPL (3)
- Type of human computer interaction: GUI for client, Web interface for experimentation
- OS/Middleware: MS Windows
- Required library or software: visual studio <http://www.visualstudio.com/en-us/products/visual-studio-express-vs.aspx>
- Programming language: C# for client, java for server, CGI and Dummynet for experimentation

#### 5.2. ElectroSmart

**Participants:** Arnaud Legout [contact], Mondri Ravi.

The Internet and new devices such as smartphones have fundamentally changed the way people communicate, but this technological revolution comes at the price of a higher exposition of the general population to microwave electromagnetic fields (EMF). This exposition is a concern for health agencies and epidemiologists who want to understand the impact of such an exposition on health, for the general public who wants a higher transparency on its exposition and the health hazard it might represent, but also for cellular operators and regulation authorities who want to improve the cellular coverage while limiting the exposition, and for computer scientists who want to better understand the network connectivity in order to optimize communication protocols. Despite the fundamental importance to understand the exposition of the general public to EMF, it is poorly understood because of the formidable difficulty to measure, model, and analyze this exposition. The goal of the ElectroSmart project is to develop the instrument, methods, and models to compute the exposition of the general public to microwave electromagnetic fields used by wireless protocols and infrastructures such as Wi-Fi, Bluetooth, or cellular. Using a pluri-disciplinary approach combining crowd-based measurements, in-lab experiments, and modeling using sparse and noisy data, we address challenges such as designing and implementing a measuring instrument leveraging on crowd-based measurements from mobile devices such as smartphones, modeling the exposition of the general public to EMF to compute

the most accurate estimation of the exposition, and analyzing the evolution of the exposition to EMF with time. This technological breakthrough will have scientific, technical, and societal applications, notably on public health politics, by providing the scientific community and potential users with a unique measuring instrument, methods, and models to exploit the invaluable data gathered by the instrument. This project is supported by the UCN@Sophia Labex in 2016/2017 (funding the engineer Mondri Ravi) In August 2016, we released the first stable public release of ElectroSmart. On the 20th December 2016 we had 1502 downloads in Google Play, an average score of 4,66/5, 800 active users, 22 millions measured signals and 500k measured geographic zones.

- URL: <http://es.inria.fr>
- Version: 1.1
- Keywords: background electromagnetic radiations
- License: Inria proprietary licence
- Type of human computer interaction: Android application
- OS/Middleware: Android
- Required library or software: Android
- Programming language: Java
- Documentation: javadoc

### 5.3. nepi-ng

**Participants:** Thierry Parmentelat [correspondant], Thierry Turletti, Mario Antonio Zancanaro.

During the past couple of years, we had developed NEPI, the Network Experimentation Programming Interface, as a wide spectrum tool for orchestrating network experiments on network experimentation platforms.

In the more specific context of R2lab, we have been facing more stringent requirements in terms of response time, especially when synchronizing the parallel parts of a wireless experiment. For that reason, and also because the NEPI codebase was starting to feel much too large for its actual usage, and consequently very brittle, we have decided to start and put together a new set of components, named **nepi-ng** for nepi new generation.

At this point, nepi-ng has a much smaller scope than NEPI used to have, in that it only supports remote control of network experiments over ssh. As a matter of fact, in practice, this is the only access mechanism that we need to have for running experiments on both R2lab, and PlanetLab Europe.

For that reason, the actual size of the nepi-ng codebase is about 12 times smaller than the one of NEPI. However, running the same experiment on R2lab turns out to be about 10 times faster using nepi-ng rather than NEPI, that in this context is impeded by its generic model for resources, that prevents NEPI from being as reactive as what can be achieved with nepi-ng.

The design of nepi-ng of course is modular, so that it will be perfectly possible to add other control mechanisms to this core if and when this becomes necessary.

- URL: <http://nepi-ng.inria.fr>
- Version: 0.5
- Keywords: networking experimentation, orchestration
- License: CC BY-SA 4.0
- Type of human computer interaction: python library
- OS/Middleware: Linux
- Required library or software: python-3.5 / asyncio
- Programming language: python3

## 5.4. OpenLISP

**Participant:** Damien Saucez [contact].

Among many options tackling the scalability issues of the current Internet routing architecture, the Locator/Identifier Separation Protocol (LISP) appears as a viable solution. LISP improves a network's scalability, flexibility, and traffic engineering, enabling mobility with limited overhead. As for any new technology, implementation and deployment are essential to gather and master the real benefits that it provides. We propose a complete open source implementation of the LISP control plane. Our implementation is deployed in the worldwide LISP Beta Network and the French LISP-Lab testbed, and includes the key standardized control plane features. Our control plane software is the companion of the existing OpenLISP dataplane implementation, allowing the deployment of a fully functional open source LISP network compatible with any implementation respecting the standards. As of 2016, OpenLISP is used to provide connectivity between satellite sites of the LISP-Lab project.

- <http://www.lisp-lab.org/>
- Version: 3.2
- ACM: C.2.1, C.2.2, C.2.6
- Keywords: routing, LISP, control-plane
- License: BSD
- Type of human computer interaction: XML, CLI
- OS/Middleware: POSIX
- Required library or software: Expat 2
- Programming language: C
- Documentation: Unix man
- Deployment: <http://ddt-root.org>

## 5.5. Platforms

### 5.5.1. *Reproducible research laboratory* (R<sup>2</sup>lab)

Scientific evaluation of network protocols requires for experiment results to be reproducible before they can be considered as valid. This is particularly difficult to obtain in the wireless networking domain, where characteristics of wireless channels are known to be variable, unpredictable and hardly controllable.

We have built at Inria Sophia-Antipolis, in the last couple of years, an anechoic chamber, with RF absorbers preventing radio waves reflections and with a Faraday cage blocking external interferences. This lab, named R<sup>2</sup>lab, represents an ideal environment for experiments reproducibility.

R<sup>2</sup>lab has been operated for 2 years now, in the context of the FIT Equipment of Excellence project, and as such, it is now federated with the other testbeds that are part of the FIT initiative. This testbed is for the long-haul, and is scheduled to remain operational until at least 2020.

During 2016, our focus regarding R<sup>2</sup>lab has been set on the following aspects. First, we have deployed USRPs (Universal Software Radio Peripherals) together with hardware devices for controlling these USRP extensions. This is extremely interesting, as it considerably widens the fields of application for the testbed. In particular, and that was our second angle for improvements this year, we have taken advantage of the USRP hardware to provide support for OpenAirInterface-based deployments in the chamber. That feature was demonstrated for example during the formal opening that took place on November 9 this year, where it was demonstrated how to set up a private LTE network in 3 minutes.

For more details see <http://r2lab.inria.fr>.

## ECUADOR Project-Team

# 5. New Software and Platforms

## 5.1. AIRONUM

Aironum is an experimental software that solves the unsteady compressible Navier-Stokes equations with k-, LES-VMS (Large Eddy Simulation - Variational Multi-Scale) and hybrid turbulence modelling on parallel platforms, using MPI. The mesh model is unstructured tetrahedrization, with possible mesh motion.

Aironum was developed by Inria and University of Montpellier. It is used by Inria, University of Montpellier and University of Pisa. Aironum is used as an experimental platform for:

- Numerical approximation of compressible flows, such as upwind mixed element volume approximation with superconvergence on regular meshes.
- Numerical solution algorithms for the implicit time advancing of the compressible Navier-Stokes equations, such as parallel scalable deflated additive Schwarz algorithms.
- Turbulence modelling such as the Variational Multiscale Large eddy Simulation and its hybridization with RANS (Reynolds Averaged Navier-Stokes) statistical models.
- Participant: Alain Dervieux
- Contact: Alain Dervieux
- URL: <http://www-sop.inria.fr/tropics/aironum>

## 5.2. TAPENADE

KEYWORDS: Static analysis - Optimization - Compilation - Gradients

Tapenade [10] is an Algorithmic Differentiation tool that transforms an original program into a new program that computes derivatives of the original program. Being an AD tool, Tapenade produces analytical derivatives exact up to machine precision, and in adjoint mode computes gradients at a cost independent of the number of input variables.

Tapenade implements the results of our research about models and static analyses for AD. Tapenade can be downloaded and installed on most architectures. Alternatively, it can be used as a web server. Higher-order derivatives can be obtained through repeated application. Tapenade accepts source programs written in Fortran77, Fortran90, or C. It provides differentiation in the following modes: tangent, vector tangent, adjoint, and vector adjoint.

Tapenade performs sophisticated data-flow analysis, flow-sensitive and context-sensitive, on the complete source program to produce an efficient differentiated code. Analyses performed are Type-Checking, Read-Write analysis, Pointer analysis, and AD-specific analyses including Activity analysis, Adjoint Liveness analysis, and TBR analysis.

- Participants: Laurent Hascoët, Valérie Pascual
- Contact: Laurent Hascoët
- URL: <http://www-sop.inria.fr/tropics/tapenade.html>

## **FOCUS Project-Team**

# **6. New Software and Platforms**

## **6.1. AIOCJ**

Adaptive Interaction-Oriented Choreographies in Jolie

SCIENTIFIC DESCRIPTION

AIOCJ is a framework for programming adaptive distributed systems based on message passing. AIOCJ comes as a plugin for Eclipse, AIOCJ-ecl, allowing one to edit descriptions of distributed systems as adaptive interaction-oriented choreographies (AIOC). From interaction-oriented choreographies the description of single participants can be automatically derived. Adaptation is specified by rules allowing to replace predetermined parts of the AIOC with a new behaviour. A suitable protocol ensures that all the participants are updated in a coordinated way. As a result, the distributed system follows the specification given by the AIOC under all changing sets of adaptation rules and environment conditions. In particular, the system is always deadlock-free. AIOCJ can interact with external services, seen as functions, by specifying their URL and the protocol they support (HTTP, SOAP, ...). Deadlock-freedom guarantees of the application are preserved provided that those services do not block.

FUNCTIONAL DESCRIPTION

AIOCJ is an open-source choreography programming language for developing adaptive systems.

- Participants: Saverio Giallorenzo, Mila Dalla Preda, Maurizio Gabbrielli, Ivan Lanese and Jacopo Mauro
- Contact: Saverio Giallorenzo
- URL: <http://www.cs.unibo.it/projects/jolie/aioj.html>

## **6.2. DF4ABS**

Deadlock Framework for ABS

SCIENTIFIC DESCRIPTION

We have prototyped a framework for statically detecting deadlocks in a concurrent object-oriented language with asynchronous method calls and cooperative scheduling of method activations (the language is ABS, which has been developed in the EU project HATS and is currently extended with primitives for cloud-computing in the EU project ENVISAGE. ABS is very similar to ASP, developed by the former OASIS team.). Since this language features recursion and dynamic resource creation, deadlock detection is extremely complex and state-of-the-art solutions either give imprecise answers or do not scale. In order to augment precision and scalability we propose a modular framework that allows several techniques to be combined. The basic component of the framework is a front-end inference algorithm that extracts abstract behavioural descriptions of methods that retain resource dependency information. Then these behavioural descriptions are analyzed by a back-end that uses a fix-point technique to derive in a deterministic way the deadlock information.

- Contact: Cosimo Laneve
- URL: <http://df4abs.nws.cs.unibo.it/>

## **6.3. HoCA**

Higher-Order Complexity Analysis

SCIENTIFIC DESCRIPTION

Over the last decade, various tools for the static analysis of resource properties of programs have emerged. In particular, the rewriting community has recently developed several tools for the time complexity analysis of term rewrite systems. These tools have matured and are nowadays able to treat non-trivial programs, in a fully automatic setting. However, none of these automatic complexity analysers can deal with higher-order functions, a pervasive feature of functional programs. HoCA (Higher-Order Complexity Analyser) overcomes this limitation by translating higher-order programs – in the form of side-effect free OCaml programs - into equivalent first-order rewrite systems. At the heart of our tool lies Reynold’s defunctionalization technique. Defunctionalization however is not enough. Resulting programs have a recursive structure too complicated to be analyzed automatically in all but trivial cases. To overcome this issue, HoCA integrates a handful of well-established program transformation techniques, noteworthy dead-code elimination, inlining, instantiation and uncurrying. All these techniques have been specifically suited to the methods integrated in modern first-order complexity analyzers. A complexity bound on the resulting first-order program can be relayed back reliably to the higher-order program of interest. A detailed description of HoCA is available on <http://arxiv.org/abs/1506.05043>

#### FUNCTIONAL DESCRIPTION

HOCA is an abbreviation for Higher-Order Complexity Analysis, and is meant as a laboratory for the automated complexity analysis of higher-order functional programs. Currently, HOCA consists of one executable `pcf2trs` which translates a pure subset of OCaml to term rewrite systems, in a complexity-reflecting manner. As a first step, HOCA desugars the given program to a variation of Plotkin’s PCF with data-constructors. Via Reynold’s defunctionalization, the PCF program is turned into an applicative term rewrite system (ATRS for short), and call-by-value reductions of the PCF program are simulated by the ATRS step-by-step. On the ATRS, various complexity reflecting transformations are performed: inlining, dead-code-elimination, instantiation of higher-order variables through a call-flow-analysis and finally uncurrying. This results in a first-order rewrite system, whose runtime-complexity asymptotically reflects the complexity of the initial program.

- Participants: Ugo Dal Lago and Martin Avanzini
- Contact: Ugo Dal Lago
- URL: <http://cbr.uibk.ac.at/tools/hoca/>

## 6.4. JOLIE

Java Orchestration Language Interpreter Engine

KEYWORD: Microservices

SCIENTIFIC DESCRIPTION

Jolie is a service-oriented programming language. Jolie can be used to program services that interact over the Internet using different communication protocols.

Differently from other Web Services programming languages such as WS-BPEL, Jolie is based on a user-friendly C/Java-like syntax (more readable than the verbose XML syntax of WS-BPEL) and, moreover, the language is equipped with a formal operational semantics. This language is used for the *proof of concepts* developed around Focus activities. For instance, contract theories can be exploited for checking the conformance of a Jolie program with respect to a given contract.

DEVELOPMENTS IN 2016

Jolie has transitioned from version 1.4.1 to version 1.6. The last version of Jolie that supports Java 1.6 is Jolie 1.5. Jolie 1.6 transitions from Java 1.6 to Java 1.8 and makes use of the new features and libraries found in the new version of Java. Version 1.6 of Jolie features:

- general performance improvements and bug fixes, in particular regarding concurrent data structures using Java lambdas,
- improvements of the standard library of the language,
- better error messages and improved compatibility with the main operating systems,
- support for type choices (AKA type sums),
- support of for-loop construct to iterate over arrays without explicit indexes,
- improved support for the HTTP protocol (and, by extension, web applications).
- Participants: Claudio Guidi, Fabrizio Montesi, Saverio Giallorenzo and Maurizio Gabbrielli
- Contact: Fabrizio Montesi
- URL: <http://www.jolie-lang.org/>

## 6.5. SRA

Static Resource Analyzer for ABS  
SCIENTIFIC DESCRIPTION

We prototype a static analysis technique that computes upper bounds of virtual machine usages in a concurrent language with explicit acquire and release operations of virtual machines. In our language it is possible to delegate other (ad-hoc or third party) concurrent code to release virtual machines (by passing them as arguments of invocations, a feature that is used by Amazon Elastic Cloud Computing or by the Docker FiWare). Our technique is modular and consists of (i) a type system associating programs with behavioural descriptions that record relevant information for resource usage (creations, releases, and concurrent operations), (ii) a translation function that takes behavioural types and returns cost equations, and (iii) an automatic off-the-shelf solver for the cost equations.

- Contact: Cosimo Laneve
- URL: <http://sra.cs.unibo.it/>

## 6.6. SUNNY-CP

SCIENTIFIC DESCRIPTION

Within the Constraint Programming paradigm, a portfolio solver combines different constraint solvers in order to create a globally better solver. Sunny-cp is a parallel portfolio solver that allows one to solve a Constraint (Satisfaction/Optimization) Problem defined in the MiniZinc language. It essentially implements the SUNNY algorithm introduced in the team. Sunny-cp is built on top of state-of-the-art constraint solvers, including: Choco, Chuffed, CPX, G12/LazyFD, G12/FD, G12/Gurobi, G12/CBC, Gecode, HaifaCSP, iZplus, MinisatID, Opturion, OR-Tools.

FUNCTIONAL DESCRIPTION

SUNNY-CP is a portfolio solver for solving both Constraint Satisfaction Problems and Constraint Optimization Problems. The goal of SUNNY-CP is to provide a flexible, configurable, and usable CP portfolio solver that can be set up and executed just like a regular individual CP solver.

- Contact: Maurizio Gabbrielli
- URL: <https://github.com/CP-Unibo/sunny-cp>

## 6.7. Blender

Aeolus Blender



KEYWORDS: Automatic deployment - Cloud applications management

SCIENTIFIC DESCRIPTION

The various tools developed in the Aeolus project (Zephyrus, Metis, Armonic) have been combined in this software which represents an integrated solution for the declarative specification of cloud applications, and its subsequent automatic deployment on an OpenStack cloud system. In particular, a web-based interface is used to specify the basic software artifacts to include in the application, indicate their level of replication, and specify co-installability conflicts (i.e. when two components cannot be installed on the same virtual machines). The tool Zephyrus is then used to synthesize the final architecture of the application, the tool Metis indicates the plan of configuration actions, and the Armonic platform provides the library of components and the low-level scripts to actually install and configure the entire application.

- Partners: IRILL - Mandriva
- Contact: Gianluigi Zavattaro
- URL: <https://github.com/aeolus-project/blender>

## GRAPHDECO Project-Team

# 5. New Software and Platforms

## 5.1. SWARPI-Unity

SWARPI-Unity (for Superpixel Warp for Image-based rendering for Unity)

This is a software module developed in collaboration with Testaluna in the context of the CR-PLAY EU project. It involves an implementation of the Image-Based rendering algorithms of the group in the Unity3D framework. The software was improved this year to support mobile Android devices and was used in the evaluation step of the CR-PLAY project and for multiple demos.

- Participants: Sebastien Bonopera, Jerome Esnault, George Drettakis and Gaurav Chaurasia
- Contact: George Drettakis

## 5.2. SIBR

SIBR (for Simple Image-Based Rendering)

This is a framework containing libraries and tools used internally for research projects based on Image-Base Rendering. It includes both preprocessing tools (computing data used for rendering) and rendering utilities. This new framework replaces the previously used IBR-COMMON tools.

- Participants: George Drettakis, Abdelaziz Djelouah, Rodrigo Ortiz Canyon, Theo Thonat, Sebastien Bonopera
- Contact: George Drettakis

## 5.3. MVIIR

MVIIR (for Multi-View Image Intrinsic Images and Relighting)

This package is the software implementation of the intrinsic image algorithm of Duchêne et al. It includes two libraries; one general-purpose that can be used to augment the functionalities of the previously mentioned SIBR framework, and another for specific logic concerning the relighting task. This package includes also programs to compute preprocess data required for the relighting of a dataset.

- Participants: George Drettakis, Sebastien Bonopera, Adrien Bousseau
- Contact: George Drettakis

## 5.4. SGTDP

SGTDP (for Synthetic Ground Truth Data Generation Platform)

We have started the development of a ground truth data generation platform based on complex and realistically rendered scenes built in 3D modelling packages such as 3DS Max. The platform includes an export module from 3DSMax with support for complex materials and shade trees such as those developed for the physically based rendering V-Ray platform. This module exports to the Mitsuba opensource renderer, and includes support for various operations using Mitsuba, as well as rendering on the Inria cluster. The platform is designed to generate ground truth data for learning as well as data for ground truth comparisons for image-based rendering projects in the group.

- Participants: George Drettakis, George Kopanas, Sai Bangaru
- Contact: George Drettakis

## GRAPHIK Project-Team

# 5. New Software and Platforms

## 5.1. SudoQual

**Participants:** Michel Leclère, Michel Chein, Alain Gutierrez, Clément Sipieter, Brett Choquet.

**Contact:** Michel Leclère

SudoQual is a software suite that allows discovering and evaluating coreference links between individual entities references. It has been developed during the ANR project Qualinca. This software suite comprises:

- a generic API allowing to implement (thanks to a graphical interface) applications computing “same-as” and “different-from” links in knowledge bases;
- a generic application (whose specific parameters are defined in a configuration file) evaluating the quality of a knowledge base; it is available either as a standalone client or as a web service;
- a library dedicated to the comparison of individual entities’ attributes;
- the specific configuration file dedicated to evaluating the quality of links in ABES’ Sudoc catalogue.

Main developments this year are:

- adapting the API’s architecture to the NetBeans IDE in order to benefit from its better edition functionalities;
- finalizing, testing and optimizing the linkage application;
- specifying and implementing the quality evaluation application;
- implementing this latter application as a web service.

## 5.2. GRAAL

**Participants:** Clément Sipieter, Jean-François Baget, Michel Leclère, Marie-Laure Mugnier, Swan Rocher.

**Contact:** Marie-Laure Mugnier (scientific contact), Clément Sipieter (technical contact)

**Keywords:** Data management - Ontologies - Query Answering

**Web site:** <https://graphik-team.github.io/graal/>

**Scientific Description** Graal is a generic platform for ontological query answering with existential rules. It implements various paradigms that fall into that framework. It is an open source software written in Java.

**Functional Description** See last year’s report for a description of GRAAL’s features <http://raweb.inria.fr/rapportsactivite/RA2015/graphik/uid49.html>.

**New Features** The main features developed in 2016 are:

- improvement of the semi-saturation algorithm with compilable rules;
- implementation of mappings allowing to query an existing database as it is, without prior loading it in GRAAL;
- design and implementation of classes that manage a knowledge base (i.e., the rules and the data). In particular, the results of the rule analyser Kiabora (that has been integrated within GRAAL) are used to automatically select the most appropriate algorithms for querying the knowledge base.

## 5.3. Cogui

**Participants:** Alain Gutierrez, Marie-Laure Mugnier, Michel Leclère, Michel Chein.

**Contact:** Marie-Laure Mugnier (scientific contact), Alain Gutierrez (technical contact)

**Keywords:** Graphical knowledge bases - Ontology Editor - Conceptual Graphs

**Web site:** <http://www.lirmm.fr/cogui/>

**Scientific Description** Cogui is a tool for building and verifying graphical knowledge bases. It is a freeware written in Java.

**Functional Description** See last year's report for a description of CoGui's features <http://raweb.inria.fr/rappportsactivite/RA2015/graphik/uid41.html>.

**New features** Cogui is currently under heavy refactoring to benefit from NetBeans graphical libraries.

## 5.4. CoGui-Capex

CoGui-Capex is a decision support tool dedicated to food industry. Its knowledge base represents the causal links between food descriptors and actions which can be undertaken by operators to control food quality on the line. The new version of CoGui-Capex developed in 2016 in a Neatbeans environnement is coupled with the so-called "Knowledge book" developed by INRA I2M team in Bordeaux [49]. This collaboration will be extended in the CASDAR Docamex national project (funded by the French Ministry of Agriculture), which will begin in January 2017 for 4 years with several cheese makers.

## 5.5. @Web

An extension of the 5 stars/FAIRS scientific data annotation platform called @Web (<http://www6.inra.fr/cati-icat-atweb>), managed by INRA, has been developed by Leandro Lovisolo (UBA master student) co-supervised by Federico Ulliana and Patrice Buche using semantic web languages (OWL, SPARQL, RDF). This extension permits to represent negative constraints expressed on annotated data and will be used in data curation phase.

## HEPHAISTOS Project-Team

# 6. New Software and Platforms

## 6.1. ALIAS

Algorithms Library of Interval Analysis for Systems

FUNCTIONAL DESCRIPTION

The ALIAS library whose development started in 1998, is a collection of procedures based on interval analysis for systems solving and optimization.

ALIAS is made of two parts:

ALIAS-C++ : the C++ library (87 000 code lines) which is the core of the algorithms

ALIAS-Maple : the Maple interface for ALIAS-C++ (55 000 code lines). This interface allows one to specify a solving problem within Maple and get the results within the same Maple session. The role of this interface is not only to generate the C++ code automatically, but also to perform an analysis of the problem in order to improve the efficiency of the solver. Furthermore, a distributed implementation of the algorithms is available directly within the interface.

- Participants: Odile Pourtallier and Jean-Pierre Merlet
- Contact: Jean-Pierre Merlet
- URL: <http://www-sop.inria.fr/hephaistos/developpements/main.html>

## 6.2. Platforms

We describe here only the new platforms that have been developed in 2016 while we maintain a very large number of platforms (e.g. the cable-driven parallel robots of the MARIONET family, the ANG family of walking aids or our experimental flat).

### 6.2.1. GMSIVE ADT: virtual reality and rehabilitation

Inria has agreed to fund us for developing the platform GMSIVE whose purpose is to introduce end-user motion and their analysis in a virtual reality environment in order to make rehabilitation exercises more attractive and more appropriate for the rehabilitation process. For example we have developed an active treadmill whose slope will change according to the user place in the virtual world while the lateral inclination may be changed in order to regulate the load between the left and right leg. Such a system may be used in rehabilitation to simulate a walk in the mountain while increasing on-demand the load on an injured leg (that is usually avoided by the user) for a shorter rehabilitation time. At the same time the walking pattern is analyzed in order to assess the efficiency of the rehabilitation exercise.

The motion system is composed of two vertical columns whose height may be adjusted (they are used for actuating the treadmill), a 6 d.o.f motion base and a cable-driven parallel robot which may lift the user (in the walking experiment this robot may be used to support partly the user while he is walking allowing frail people to start the rehabilitation earlier). We intend to develop sailing and ski simulators as additional rehabilitation environment. Currently the columns and motion base are effective while the robot has been installed but not tested yet and we have started to study the coupling between the motion generators and the 3D visualization.

### 6.2.2. Activities detection platform

For non intrusive activities detection we use low cost distance and motion sensors that are incorporated in a 3D printed box (figure 1 ) and constitute a detection station. Several such station are implemented at appropriate place in the location that has to be monitored (e.g. the Valrose EHPAD where 15 such stations has been deployed at the end of 2016 while 17 stations will be deployed at Institut Claude Pompidou at the very beginning of 2017). Although the information provided by each station is relatively poor an appropriate network of such station allow us to provide the information requested by the medical community.

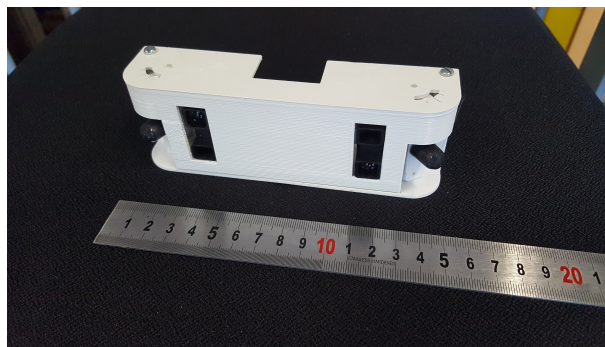

*Figure 1. A station for activities detection. The 4 sensors allow to determine the presence of the subject in a given zone, his/her direction of motion and speed even at night*

## INDES Project-Team

# 4. New Software and Platforms

## 4.1. Hop

KEYWORDS: Domotique - Web 2.0 - Iot - Functional language - Programming  
SCIENTIFIC DESCRIPTION

Hop.js is a platform for web, cloud, and IoT applications. Its development environment is composed of:

- a programming language named HopScript, which is based on ECMAScript 262, //aka// JavaScript;
- an optimized web server;
- on-the-fly compilers for generating HTML, CSS, and client-side JavaScript;
- an ahead-of-time compiler for compiling JavaScript to native code;
- numerous APIs for networking, multimedia, robotics, IoT, etc.

The HopScript language extends JavaScript to consistently define the server and client part of web applications and IoT applications. HopScript supports syntactic forms that help creating HTML elements. It supports services that enable function calls over HTTP. Being at higher level than traditional Ajax programming, Hop.js services avoid the burden and pitfalls of URL management and explicit data marshalling. They combine the benefits of a high level RPC mechanism and low level HTTP compatibility.

Although Hop.js can be used to develop traditional web servers, it is particularly adapted to the development of web applications embedded into devices, where the server and client part of the application are intimately interoperating with each other. The programming model of Hop.js fosters the joint specification of server and client code, and allows the rapid development of web user interfaces, on the client, controlling the execution of the distributed application. By defining a single data model, providing functions that can run indifferently on both sides, and almost forgetting about client-server protocols, Hop.js seems well suited for agile development of web applications for this class of applications.

- Participants: Manuel Serrano and Vincent Prunet
- Contact: Manuel Serrano
- URL: <http://hop.inria.fr>

## 4.2. Mashic

FUNCTIONAL DESCRIPTION

The Mashic compiler is applied to mashups with untrusted scripts. The compiler generates mashups with sandboxed scripts, secured by the same origin policy of the browsers. The compiler is written in Bigloo.

- Contact: Tamara Rezk
- URL: <http://web.ist.utl.pt/~ana.matos/Mashic/mashic.html>

## 4.3. Webstats

Webstats is a follow-up of the internship on JavaScript constructs used in top Alexa sites, started in summer 2015 by Dolière Francis Some. He analyzed the top 10,000 Alexa sites, and provided statistics about them. Among those statistics, their are:

- the most popular JavaScript libraries
- the most recurrent JavaScript constructs
- the adoption of security features such as:
  - The Content Security Policy, a policy for defending against Cross-Site-Script attacks
  - HttpOnly and Secure cookies, that prevents attacks like session hijacking.

Starting from April, 2016, this study is performed periodically, at the end of each month. The results are accessible online at <https://webstats.inria.fr>.

- Contact: Francis Some
- URL: <https://webstats.inria.fr>

## LAGADIC Project-Team

# 6. New Software and Platforms

## 6.1. DESlam

Dense Egocentric SLAM

KEYWORDS: Depth Perception - Robotics - Localization

FUNCTIONAL DESCRIPTION

This software proposes a full and self content solution to the dense Slam problem. Based on a generic RGB-D representation valid for various types of sensors (stereovision, multi-cameras, RGB-D sensors...), it provides a 3D textured representation of complex large indoor and outdoor environments and it allows localizing in real time (45Hz) a robot or a person carrying out a mobile camera.

- Participants: Maxime Meilland, Andrew Ian Comport and Patrick Rives
- Contact: Patrick Rives
- URL: <http://team.inria.fr/lagadic>

## 6.2. HandiViz

KEYWORDS: Health - Persons attendant - Handicap

FUNCTIONAL DESCRIPTION

The HandiViz software proposes a semi-autonomous navigation framework of a wheelchair relying on visual servoing.

It has been registered to the APP (“Agence de Protection des Programmes”) as an INSA software (IDDN.FR.001.440021.000.S.P.2013.000.10000) and is under GPL license.

- Participants: Francois Pasteau and Marie Babel
- Contact: Marie Babel
- URL: <https://team.inria.fr/lagadic/>

## 6.3. Perception360

Robot vision and 3D mapping with omnidirectional RGB-D sensors.

KEYWORDS: Depth Perception - 3D rendering - Computer vision - Robotics - Image registration - Sensors - Realistic rendering - 3D reconstruction - Localization

FUNCTIONAL DESCRIPTION

This software is a collection of libraries and applications for robot vision and 3D mapping with omnidirectional RGB-D sensors or standard perspective cameras. It provides the functionalities to do image acquisition, semantic annotation, dense registration, localization and 3D mapping. The omnidirectional RGB-D sensors used within this software have been developed at Inria Sophia Antipolis.

- Participants: Eduardo Fernandez Moral, Renato José Martins and Patrick Rives
- Contact: Patrick Rives
- URL: <https://team.inria.fr/lagadic>

## 6.4. Sinatrack

KEYWORDS: Computer vision - Robotics

FUNCTIONAL DESCRIPTION



Sinatrack is a tracking software that performs the 3D localization (translation and rotation) of an object with respect to a monocular camera. It allows considering objects with complex shape. The underlying approach is a model-based tracking technique. It has been developed for satellite localization and on-orbit service applications but is also suitable for augmented reality purpose.

- Participants: Antoine Petit, Eric Marchand and Francois Chaumette
- Contact: Eric Marchand
- URL: <http://team.inria.fr/lagadic>

## 6.5. UsTk

Ultrasound Toolkit

KEYWORDS: Echographic imagery - Image reconstruction - Active contours - Medical robotics

FUNCTIONAL DESCRIPTION

UsTk, standing for Ultrasound Toolkit, is a cross-platform library for two- and three-dimensional ultrasound image processing and visual servoing based on ultrasound images. Written in C++, UsTk provides tools for ultrasound image acquisition, processing, and display, as well as control of ultrasound probe motion by ultrasound visual servoing. This year we started the development of a new version. The objective is first to consolidate existing developments, to improve the quality of the software, to add new state-of-the-art algorithms, and then to disseminate them within the community as an open-source software.

- Participants: Marc Pouliquen, Alexandre Krupa, Pierre Chatelain and Fabien Spindler
- Contact: Alexandre Krupa
- URL: <https://team.inria.fr/lagadic/>

## 6.6. ViSP

KEYWORDS: Computer vision - Robotics - Augmented reality - Visual servoing

SCIENTIFIC DESCRIPTION

Since 2005, we have been developing and releasing ViSP [5], an open source library available from <http://visp.inria.fr>. ViSP standing for Visual Servoing Platform allows prototyping and developing applications using visual tracking and visual servoing techniques at the heart of the Lagadic research. ViSP was designed to be independent from the hardware, to be simple to use, expandable and cross-platform. ViSP allows to design vision-based tasks for eye-in-hand and eye-to-hand visual servoing that contains the most classical visual features that are used in practice. It involves a large set of elementary positioning tasks with respect to various visual features (points, segments, straight lines, circles, spheres, cylinders, image moments, pose...) that can be combined together, and image processing algorithms that allow tracking of visual cues (dots, segments, ellipses...) or 3D model-based tracking of known objects or template tracking. Simulation capabilities are also available.

FUNCTIONAL DESCRIPTION

ViSP provides simple ways to integrate and validate new algorithms with already existing tools. It follows a module-based software engineering design where data types, algorithms, sensors, viewers and user interaction are made available. Written in C++, ViSP is based on open-source cross-platform libraries (such as OpenCV) and builds with CMake. Several platforms are supported, including OSX, Windows and Linux. ViSP online documentation allows to ease learning. More than 250 fully documented classes organized in 16 different modules, with more than 200 examples and 35 tutorials are proposed to the user. ViSP is released under a dual licensing model. It is open-source with a GNU GPLv2 license. A professional edition license that replaces GNU GPLv2 is also available.

- Participants: François Chaumette, Eric Marchand, Fabien Spindler, Aurélien Yol and Souriya Trinh
- Partner: Inria, Université de Rennes 1
- Contact: Fabien Spindler
- URL: <http://visp.inria.fr>

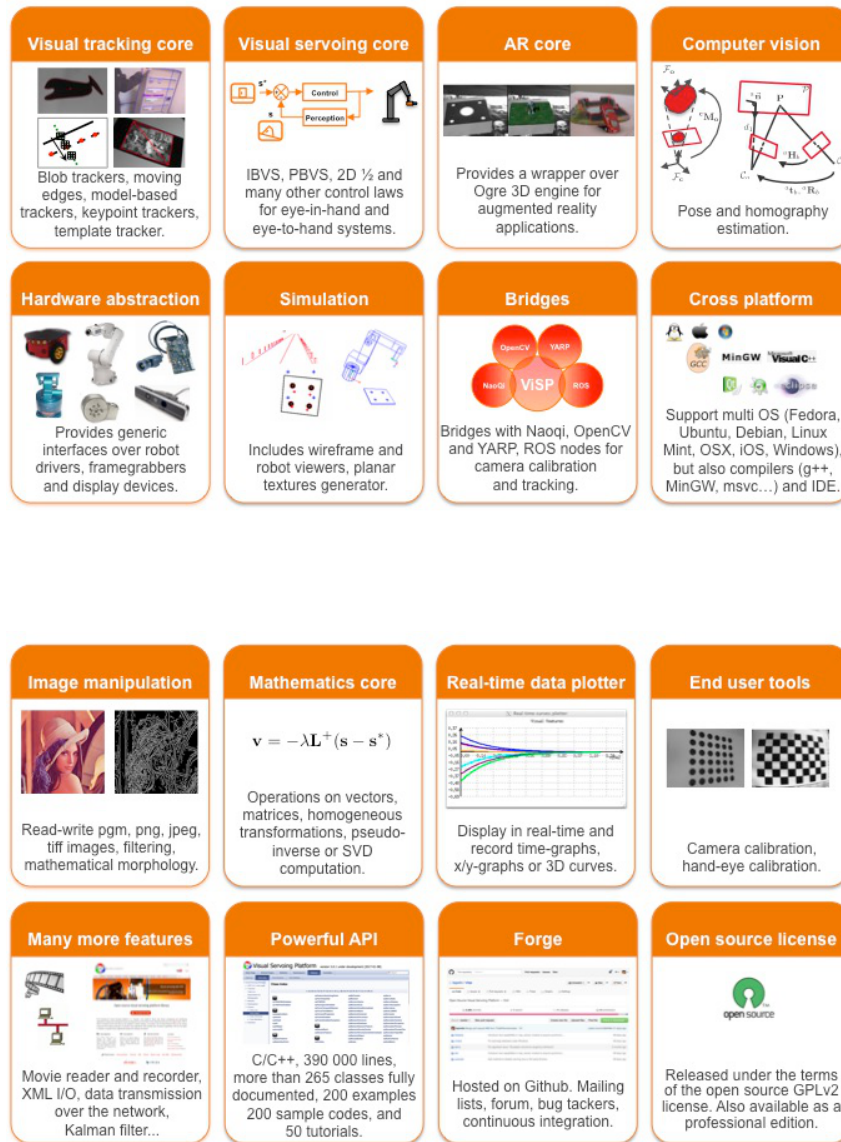

Figure 1. This figure highlights ViSP main capabilities for visual tracking, visual servoing, and augmented reality that may benefit from computer vision algorithms. ViSP allows controlling specific platforms through hardware abstraction or in simulation. ViSP provides also bridges over other frameworks such as OpenCV and ROS. All these capabilities are cross-platform. Moreover, for easing the prototyping of applications, ViSP provides tools for image manipulation, mathematics, data plotting, camera calibration, and many other features. ViSP powerful API is fully documented and available on Github as an open source software under GPLv2 license.

In December 2015, ViSP 3.0.0 new modular architecture was released. The corresponding source code tarball was downloaded 2138 times, much more than the previous 2.10.0 release that was downloaded 1412 times. This confirms that ViSP popularity is increasing and motivates the efforts we are doing since more than 10 years to improve the software. ViSP 3.0.0 last release was packaged for Debian, Ubuntu 16.04 LTS, Arch Linux, OSX and ROS. ViSP 3.0.1 next release is in preparation and should be released at the beginning of 2017. This release will be also packaged for iOS devices. In this new version we introduced new wrapper for USB-3 or GigE PointGrey cameras, Haption haptic device, ATI force/torque sensors, Intel RealSense RGB-D devices. We also make an effort to optimize some critical code sections using SSE and make possible cross-compilation for Raspberry PI and iOS targets, and also Nao, Romeo and Pepper robots from SoftBank Robotics. We also introduce a new version of the 3D model-based tracker dedicated to stereo tracking, fixed some issues, improved the documentation by providing new tutorials and by updating the existing ones.

Concerning ROS community, all the existing packages in “`vision_visp`” ROS stack (see [http://wiki.ros.org/vision\\_visp](http://wiki.ros.org/vision_visp)) were updated and ported to kinetic build system. To ease ViSP usage in the ROS framework, the releases of the year were packaged for ROS.

ViSP is used in research labs in France, USA, Canada, Japan, Korea, India, China, Italy, Spain, Portugal, etc. For instance, it is used as a support in graduate courses at IFMA Clermont-Ferrand, University of Picardie in Amiens, Télécom Physique in Strasbourg and ESIR in Rennes. Last August, during the Intel Developer Forum opening keynote, Intel CEO Brian Krzanich introduced the Intel Joule compute module. Using an Intel Joule with glasses from French company PivotHead, Intel demonstrated an augmented reality application that was using ViSP (<https://www.youtube.com/watch?v=QRBofzL4MDY>).

## 6.7. WarpDriver

KEYWORDS: Crowd Simulation - Pedestrian Simulation - Collision Avoidance - Reactive Navigation

FUNCTIONAL DESCRIPTION

WarpDriver is a microscopic crowd simulation software, which simulates the collision-free locomotion of many individual agents among the obstacles of a given environment. The originality of the algorithm relies on motion prediction mechanism which allows each agent to predict the probability of colliding other agents with respect to their current motion, their past motion, and the presence of obstacles forcing agents to follow some paths in the environment. Agents then move to their goal whilst they minimize their probability of colliding obstacles.

- Participants: David Wolinski and Julien Pettré
- Contact: Julien Pettré
- URL: <http://team.inria.fr/lagadic>

## 6.8. bib2html

FUNCTIONAL DESCRIPTION

The purpose of this software is to automatically produce html pages from BibTEX files, and to provide access to the BibTEX entries by several criteria: year of publication, category of publication, keywords, author name. Moreover cross-linking is generating between pages to provide an easy navigation through the pages without going back to the index.

- Contact: Eric Marchand
- URL: <http://www.irisa.fr/lagadic/soft/bib2html/bib2html.html>

## 6.9. Platforms

### 6.9.1. Robot vision platform

**Participant:** Fabien Spindler [contact].

We exploit two industrial robotic systems built by Afma Robots in the nineties to validate our researches in visual servoing and active vision. The first one is a Gantry robot with six degrees of freedom, the other one is a cylindrical robot with four degrees of freedom (see Fig. 2 .a). These robots are equipped with cameras. The Gantry robot also allows embedding grippers on its end-effector.

This year we completed the platform with a haptic Virtuose 6D device from Haption company (see Fig. 2 .b). This device is used for visual-based shared control (see Section 9.3.1.3 ).

Note that 3 papers published by Lagadic in 2016 enclose results validated on this platform [21][48][46].

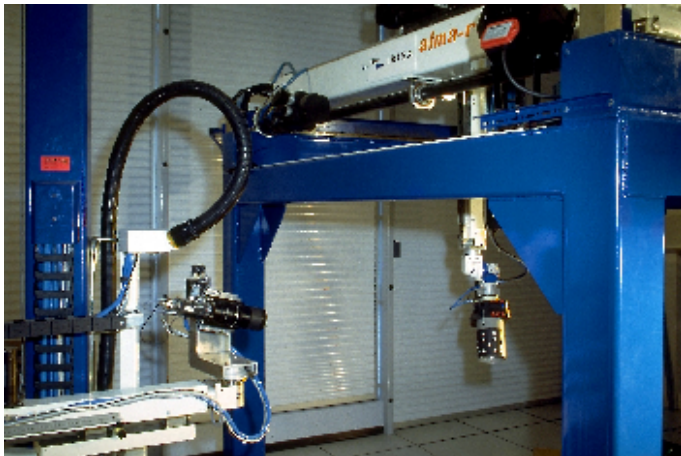

(a)



(b)

Figure 2. a) Lagadic robotics platform for vision-based manipulation, b) Virtuose 6D haptic device

## 6.9.2. Mobile robots

**Participants:** Fabien Spindler [contact], Marie Babel, Patrick Rives.

### 6.9.2.1. Indoor mobile robots

For fast prototyping of algorithms in perception, control and autonomous navigation, the team uses Hannibal in Sophia Antipolis, a cart-like platform built by Neobotix (see Fig. 3 .a), and, in Rennes, a Pioneer 3DX from Adept (see Fig. 3 .b). These platforms are equipped with various sensors needed for Slam purposes, autonomous navigation and sensor-based control.

Moreover, to validate the researches in personally assisted living topic (see Section 7.4.5 ), we have three electric wheelchairs in Rennes, one from Permobil, one from Sunrise and the last from YouQ (see Fig. 3 .c). The control of the wheelchair is performed using a plug and play system between the joystick and the low level control of the wheelchair. Such a system lets us acquire the user intention through the joystick position and control the wheelchair by applying corrections to its motion. The wheelchairs have been fitted with cameras and ultrasound sensors to perform the required servoing for assisting handicapped people.

Note that 11 papers exploiting the indoors mobile robots were published this year [67][26][61][37][62][30][55][38][71][64][66].

### 6.9.2.2. Outdoor vehicles

A camera rig has been developed in Sophia Antipolis. It can be fixed to a standard car (see Fig. 4 ), which is driven at a variable speed depending on the road/traffic conditions, with an average of 30 km/h and a maximum

speed of 80 km/h. The sequences are recorded at a frame rate of 20 Hz, where the six global shutter cameras of the stereo system are synchronized, producing spherical images with a resolution of 2048x665 (see Fig. 4 ). Such sequences are fused offline to obtain maps that can be used later for localization or for scene rendering (in a similar fashion to Google Street View) as shown in the video <http://www-sop.inria.fr/members/Renato-Jose.Martins/iros15.html>.

Paper [68] contains experimental results obtained with this camera rig.

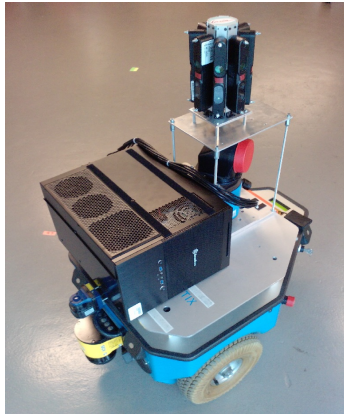

(a)



(b)



(c)

Figure 3. a) Hannibal platform, b) Pioneer P3-DX robot, c) wheelchairs from Permobil, Sunrise and YouQ.

### 6.9.3. Medical robots

**Participants:** Fabien Spindler [contact], Alexandre Krupa.

This testbed is of primary interest for researches and experiments concerning ultrasound visual servoing applied to probe positioning, soft tissue tracking or robotic needle insertion tasks (see Section 7.3 ).



*Figure 4. Globeye stereo sensor and acquisition system.*

This platform is composed by two Adept Viper six degrees of freedom arms (see Fig. 5 .a). Ultrasound probes connected either to a SonoSite 180 Plus or an Ultrasonix SonixTouch imaging system can be mounted on a force torque sensor attached to each robot end-effector.

This year we replaced the F/T sensor attached to one of the Viper robot in order to use a DAQ acquisition board able to provide measures at a higher frame rate (up to 1 kHz). This feature is especially useful for flexible needle steering by ultrasound visual servoing (see Fig. 5 .b).

Notice that 10 papers published this year include experimental results obtained with this platform [40][31][34][58][57][70][52][59] [50][51].

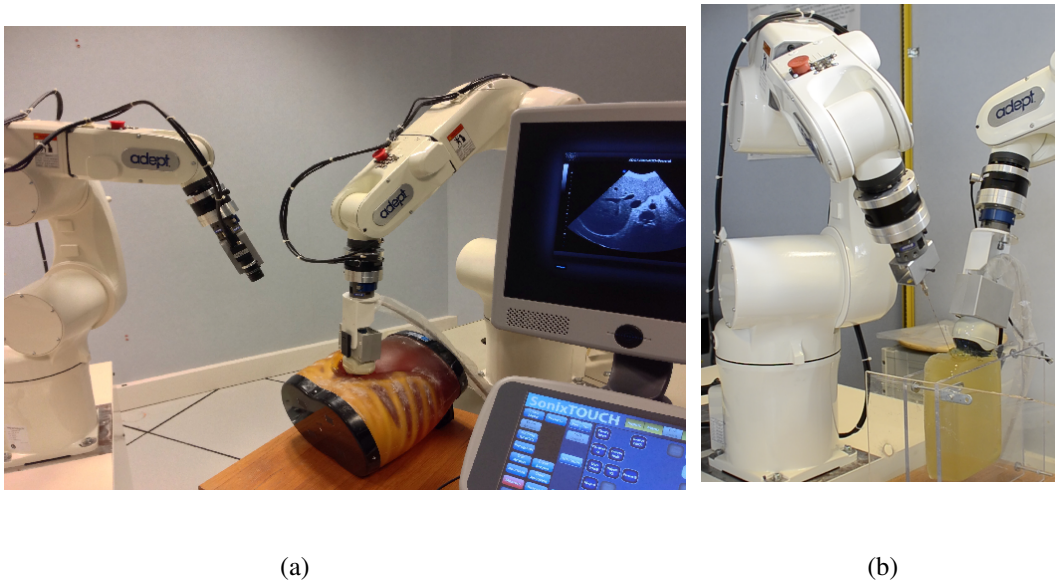

Figure 5. a) Lagadic medical robotics platforms. On the right Viper S850 robot arm equipped with a SonixTouch 3D ultrasound probe. On the left Viper S650 equipped with a tool changer that allows to attach a classical camera or biopsy needles. b) Robotic setup for autonomous needle insertion by visual servoing.

#### 6.9.4. Humanoid robots

**Participants:** Giovanni Claudio, Fabien Spindler [contact].

Romeo is a humanoid robot from SoftBank Robotics which is intended to be a genuine personal assistant and companion. For the moment only the upper part of the body (trunk, arms, neck, head, eyes) is working. This research platform is used to validate our researches in visual servoing and visual tracking for object manipulation (see Fig. 6 .a).

In July, this platform was extended with Pepper, another human-shaped robot designed by SoftBank Robotics to be a genuine day-to-day companion (see Fig. 6 .b). It has 17 degrees of freedom mounted on a wheeled holonomic base and a set of sensors (cameras, laser, ultrasound, inertial) that makes this platform interesting for researches in vision-based manipulation and navigation. Our first developments were devoted to visual servoing for controlling the gaze of the robot exploiting the redundancy of the head and mobile base and adding the capability to follow a person.

Note that 4 papers published this year include experimental results obtained with these platforms [53][81][65][20].

#### 6.9.5. Unmanned Aerial Vehicles (UAVs)

**Participants:** Thomas Bellavoir, Paolo Robuffo Giordano [contact].

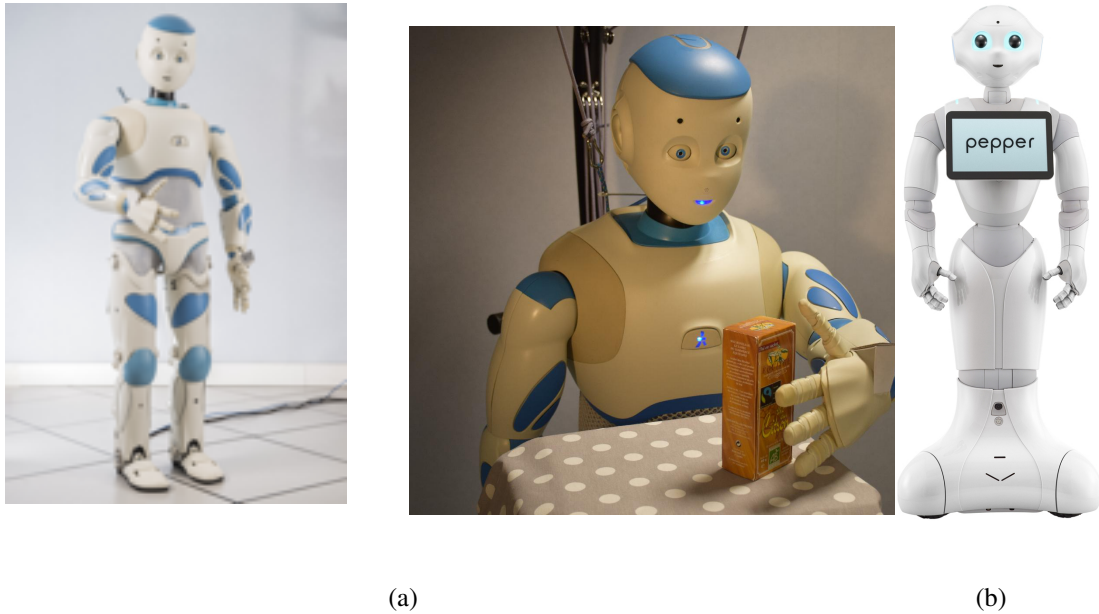

Figure 6. a) Romeo experimental platform, b) Pepper human-shaped robot

From 2014, Lagadic also started some activities involving perception and control for single and multiple quadrotor UAVs, especially thanks to a grant from “Rennes Métropole” (see Section 9.1.5 ) and the ANR project “SenseFly” (see Section 9.2.5 ). To this end, we purchased four quadrotors from Mikrokopter GmbH, Germany (see Fig. 7 .a), and one quadrotor from 3DRobotics, USA (see Fig. 7 .b). The Mikrokopter quadrotors have been heavily customized by: (i) reprogramming from scratch the low-level attitude controller onboard the microcontroller of the quadrotors, (ii) equipping each quadrotor with an Odroid XU4 board (see Fig. 7 .d) running Linux Ubuntu and the TeleKyb software (the middleware used for managing the experiment flows and the communication among the UAVs and the base station), and (iii) purchasing the Flea Color USB3 cameras together with the gimbal needed to mount them on the UAVs (see Fig. 7 .c). The quadrotor group is used as robotic platforms for testing a number of single and multiple flight control schemes with a special attention on the use of onboard vision as main sensory modality.

Two papers published this year enclose experimental results obtained with this platform [72][64].





(a)



(b)



(c)

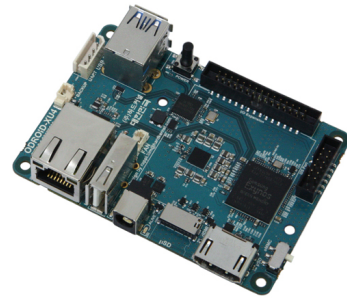

(d)

Figure 7. a) Quadrotor XLI from Mikrokopter, b) Quadrotor Iris from 3DRobotics, c) Flea Color USB3 camera, d) Odroid XU4 board

## LEMON Team

# 6. New Software and Platforms

## 6.1. TsunamiLab

**Participant:** Antoine Rousseau.

Tsunami-Lab is an educational platform enabling simulation and visualization of tsunami effects in real time, with several historical scenarios and the possibility to build your own one. The target of this project is to provide students as well as general audience with an educational tool, intended to reduce tsunamis impact in Chile and help sparing human lives.

Tsunami-Lab was initiated by José Galaz, engineer in mathematics and civil engineering, when he was working at the National Research Center for Integrated Gestion of Natural Hazards (CIGIDEN). The app is born with the match of a need - teach general audience more efficient methods to decrease tsunamis impact and spare human lives - and the use of new technologies. Later, a collaboration came up between CIGIDEN, Inria Chile and Inria (team LEMON) in order to optimize this project development.

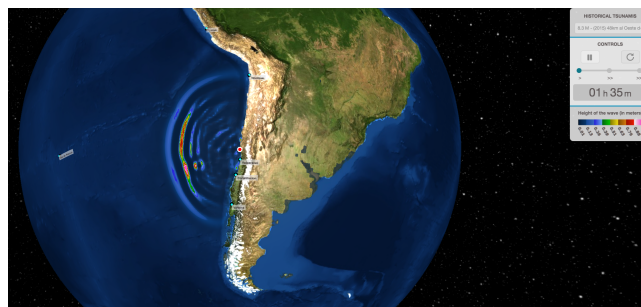

Figure 2. Propagation of a tsunami wave created by the a 8.3M earthquake in Chile (2015) using the TsunamiLab platform.

- Participant: Antoine Rousseau
- Contact: José Galaz, [jdgalmaz@gmail.com](mailto:jdgalmaz@gmail.com)
- URL: <https://tsunamilab.inria.fr/>

## 6.2. SW2D

**Participants:** Carole Delenne, Vincent Guinot.

Urban floods are usually simulated using two-dimensional shallow water models. A correct representation of the urban geometry and hydraulics would require that the average computational cell size be between 0.1 m and 1 m. The meshing and computation costs make the simulation of entire districts/conurbations impracticable in the current state of computer technology.

An alternative approach consists in upscaling the shallow water equations using averaging techniques. This leads to introducing storage and conveyance porosities, as well as additional source terms, in the mass and momentum balance equations. Various versions of porosity-based shallow water models have been proposed in the literature. The Shallow Water 2 Dimensions (SW2D) computational code embeds various finite volume discretizations of these models. It uses fully unstructured meshes with arbitrary numbers of edges. The key features of the models and numerical techniques embedded in SW2D are

- specific momentum/energy dissipation models that are active only under transient conditions. Such models, that are not present in classical shallow water models, stem from the upscaling of the shallow water equations and prove essential in modeling the features of fast urban flow transients accurately
- three different closure relationships between the averaged flow variables and porosity-based fluxes
- modified HLLC solvers for an improved discretization of the momentum source terms stemming from porosity gradients
- higher-order reconstruction techniques that allow for faster and more stable calculations in the presence of wetting/drying fronts.

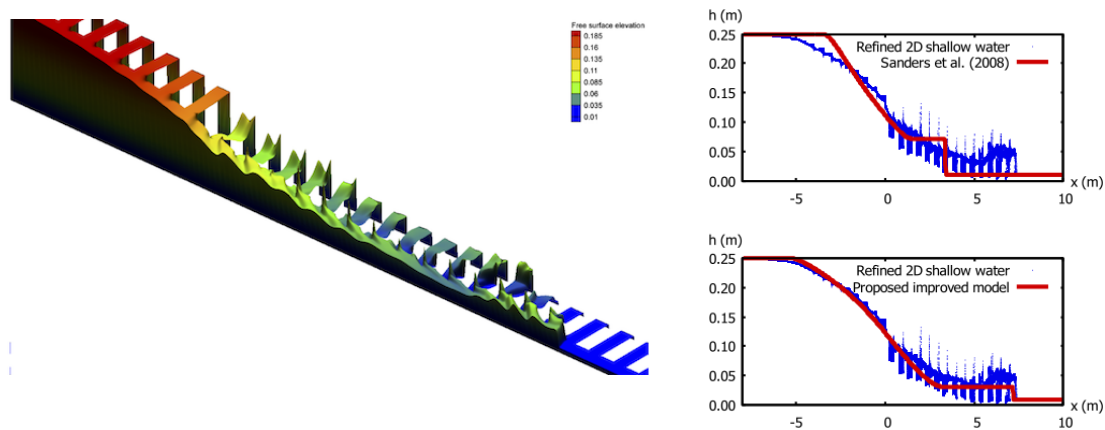

Figure 3. Propagation of a flood wave into a channel with lateral storage. Refined 2D simulation using the SW2D computational code

- Contact: Vincent Guinot
- URL: <http://vincentguinot.free.fr>

### 6.3. WindPoS

**Participant:** Antoine Rousseau.

The computation of the wind at small scale and the estimation of its uncertainties is of particular importance for applications such as wind energy resource estimation. To this aim, starting in 2005, we have developed a new method based on the combination of an existing Numerical Weather Prediction model providing a coarse prediction, and a Lagrangian Stochastic Model for turbulent flows. This Stochastic Downscaling Method (SDM) requires a specific modeling of the turbulence closure, and involves various simulation techniques whose combination is totally original (such as Poisson solvers, optimal transportation mass algorithm, original Euler scheme for confined Langevin stochastic processes, and stochastic particle methods).

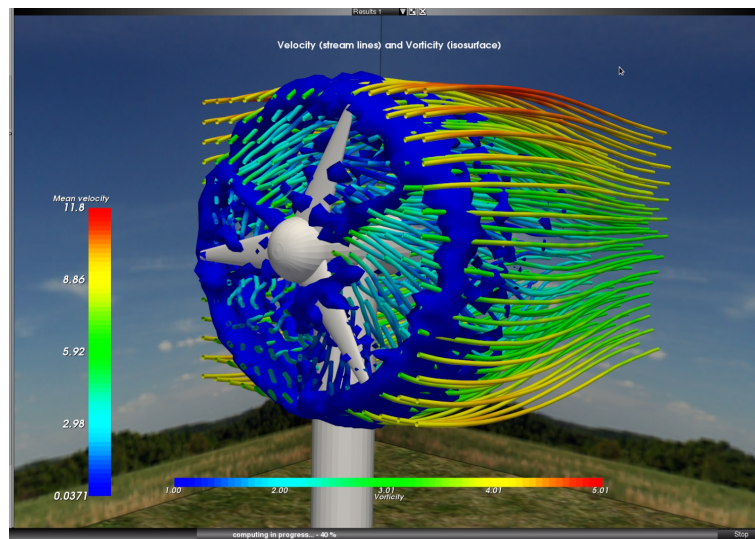

Figure 4. Velocity streamlines and vorticity around a wind mill (artistic view). WINDPOS Project.

In 2013, WindPoS became the kernel of the wind farm modeling of the Fundacion Inria Chile. In France, its development is going on through the collaborative Modéol project on the evaluation of wind potential.

This is a joint work with Mireille Bossy from the team TOSCA.

- Contact: Mireille Bossy, mireille.bossy@inria.fr
- URL: <http://windpos.inria.fr>

## MAESTRO Project-Team

# 6. New Software and Platforms

## 6.1. marmoteCore

Markov Modeling Tools and Environments - the Core

KEYWORDS: Modeling - Stochastic models - Markov model

FUNCTIONAL DESCRIPTION

marmoteCore is a C++ environment for modeling with Markov chains. It consists in a reduced set of high-level abstractions for constructing state spaces, transition structures and Markov chains (discrete-time and continuous-time). It provides the ability of constructing hierarchies of Markov models, from the most general to the particular, and equip each level with specifically optimized solution methods.

This software is developed within the ANR MARMOTE project: ANR-12-MONU-00019.

- Participants: Alain Jean-Marie, Issam Rabhi
- Partner: UVSQ (Univ. Versailles Saint-Quentin)
- Contact: Alain Jean-Marie
- URL: <http://marmotecore.gforge.inria.fr/>

## 6.2. ns-3

KEYWORDS: Simulation - Communication networks

FUNCTIONAL DESCRIPTION

ns-3 is a discrete-event network simulator for Internet systems, targeted primarily for research and educational use.

In the framework of the research project with ALSTOM Transport (see §8.1.3 ), we have extensively validated several modules of ns-3, related to the PHY and the MAC layers. We have implemented a directional antenna using 3-dimensional data for the radiation diagram. Modules related to the Automatic Train Protection function used in train systems have been implemented and validated. We have also developed a generator of video traffic and objects that allow to generate easily simulation scenarios.

We have made available the code related to the communication based train control and the one generating video traffic. Some of our contribution to the ns-3 simulator and selected results illustrating some of the issues that can be addressed using our contribution are presented and discussed in [35].

- Participants: Sara Alouf, Giovanni Neglia and Alina Tuholukova
- Contact: Alina Tuholukova
- ns-3 codereview issue of the cbtc module: <https://codereview.appspot.com/289110043>
- ns-3 codereview issue of the video generator: <https://codereview.appspot.com/286160043>

## MARELLE Project-Team

# 4. New Software and Platforms

## 4.1. Coq

The Coq Proof Assistant

KEYWORDS: Proof - Certification - Formalisation

FUNCTIONAL DESCRIPTION

Coq provides both a dependently-typed functional programming language and a logical formalism, which, altogether, support the formalisation of mathematical theories and the specification and certification of properties of programs. Coq also provides a large and extensible set of automatic or semi-automatic proof methods. Coq's programs are extractible to OCaml, Haskell, Scheme, ...

- Participants: Benjamin Gregoire, Enrico Tassi, Bruno Barras, Yves Bertot, Pierre Boutillier, Xavier Clerc, Pierre Courtieu, Maxime Dénès, Stephane Glondu, Vincent Gross, Hugo Herbelin, Pierre Letouzey, Assia Mahboubi, Julien Narboux, Jean-Marc Notin, Christine Paulin-Mohring, Pierre-Marie Pedrot, Loic Pottier, Matthias Puech, Yann Regis-Gianas, François Ripault, Matthieu Sozeau, Arnaud Spiwack, Pierre-Yves Strub, Benjamin Werner, Guillaume Melquiond and Jean-Christophe Filliatre
- Partners: CNRS - ENS Lyon - Université Paris-Diderot - Université Paris-Sud
- Contact: Matthieu Sozeau
- URL: <http://coq.inria.fr/>

The Marelle team, in collaboration with the pi.r2 team, plays an important role in the development of Coq. During this year, we contributed to the 8.6 version of Coq, released in December. As the *release manager*, Maxime Dénès led the implementation of a time-based release process, aiming at shorter and more predictable release cycles. We successfully transitioned to 10-month cycles and hope to soon move to 6-month cycles, making it easier for users to benefit from the latest improvements.

At a more detailed level, members of the Marelle team attended the Coq developer meetings (organized in Paris by Maxime Dénès and Matthieu Sozeau) and contributed to the development of Coq concerning bug fixes for virtual machine execution (Benjamin Grégoire and Maxime Dénès), cleaning up the API for plug-in developers (Matej Košík), improving the State Transaction Machine (Enrico Tassi), setting up a package index based on OPAM (Enrico Tassi), introducing a system to discuss Coq Enhancement Proposals (Enrico Tassi), and implementing a new configurable system of warnings (Maxime Dénès).

We supervise of an engineer working at MIT on questions related to efficient proof construction and proof development environments, in cooperation with researchers from the pi.r2 team. The collaboration with MIT was also an occasion to reflect on the licence framework governing collaborations around the Coq system.

We also prepared the set-up of a consortium to gather intensive users and contributors to the development of Coq. This was an occasion to work with the promoters of the InriaSoft structure which is expected to host the consortium in the long run.

## 4.2. Easycrypt

FUNCTIONAL DESCRIPTION

EasyCrypt is a toolset for reasoning about relational properties of probabilistic computations with adversarial code. Its main application is the construction and verification of game-based cryptographic proofs. EasyCrypt can also be used for reasoning about differential privacy.

- Participants: Gilles Barthe, Benjamin Gregoire and Pierre-Yves Strub
- Contact: Benjamin Grégoire
- URL: <https://www.easycrypt.info/trac/>

This year, development on this software system concerned the development of new logical settings to work on differential privacy problems: a Hoare logic based on union bound and a logic based on probabilistic couplings.

### 4.3. Math-Components

Mathematical Components library

FUNCTIONAL DESCRIPTION

The Mathematical Components library is a set of Coq libraries that cover the mechanization of the proof of the Odd Order Theorem.

- Participants: Andrea Asperti, Jeremy Avigad, Yves Bertot, Cyril Cohen, Francois Garillot, Georges Gonthier, Stéphane Le Roux, Assia Mahboubi, Sidi Ould Biha, Ioana Pasca, Laurence Rideau, Alexey Solovyev, Enrico Tassi, Laurent Théry and Russell O'Connor
- Contact: Assia Mahboubi
- URL: <http://www.msr-inria.fr/projects/mathematical-components-2/>

This year we contributed to the library by adding a new module to cover finite sets within potentially infinite finite types, organizing tutorials and schools to teach its usage:

- in January in Sophia Antipolis (one-week format) <https://team.inria.fr/marelle/en/advanced-coq-winter-school-2016/> (organized by Enrico Tassi, with contributions by Cyril Cohen, Laurence Rideau, Laurent Théry)
- in August in Nancy (one-day tutorial format, colocated with the ITP conference, organized by Assia Mahboubi and Enrico Tassi, with contributions by Yves Bertot, Cyril Cohen, and Laurent Théry) <https://github.com/math-comp/wiki/wiki/tutorial-ity2016>
- in November in Sophia Antipolis <https://team.inria.fr/marelle/en/advanced-coq-winter-school-2016-2017/> (organized by Enrico Tassi, with contributions by Yves Bertot, Cyril Cohen, Laurence Rideau).

### 4.4. Ssreflect

FUNCTIONAL DESCRIPTION

Ssreflect is a tactic language extension to the Coq system, developed by the Mathematical Components team.

- Participants: Cyril Cohen, Yves Bertot, Laurence Rideau, Enrico Tassi, Laurent Théry, Assia Mahboubi and Georges Gonthier
- Contact: Yves Bertot
- URL: <http://ssr.msr-inria.inria.fr/>

This year we mainly performed maintenance operations on this software extension to the Coq system (Enrico Tassi).

### 4.5. Zoocrypt

FUNCTIONAL DESCRIPTION

ZooCrypt is an automated tool for analyzing the security of padding-based public-key encryption schemes (i.e. schemes built from trapdoor permutations and hash functions). This year, we extended the tool to be able to deal with schemes based on cyclic groups and bilinear maps.

- Participants: Benjamin Gregoire, Gilles Barthe and Pierre-Yves Strub
- Contact: Benjamin Grégoire
- URL: <https://www.easycrypt.info/zoocrypt/>

## MATHNEURO Team

# 4. New Software and Platforms

## 4.1. New Software

### 4.1.1. Julia library *LSODA.jl*

**LSODA.jl** is a Julia package that interfaces to the **liblsoda** library, developed by Simon Frost (University of Cambridge), thereby providing a way to use the LSODA algorithm from Linda Petzold and Alan Hindmarsh from Julia.

### 4.1.2. Julia library *PDMP.jl*

**PDMP.jl** This is a joint work of Romain Veltz and Simon Frost.

**PDMP.jl** is a Julia package that allows simulation of Piecewise Deterministic Markov Processes (PDMP); this encompasses hybrid systems, comprising of continuous and discrete components, as well as processes with time-varying rates. It is based on an implementation of the True Jump Method for performing stochastic simulations of PDMP, and requires solving stiff ODEs in an efficient manner. **Sundials.jl** is used, but other solvers could be easily added.



## **MCTAO Project-Team**

# **5. New Software and Platforms**

## **5.1. Hampath**

KEYWORDS: Geometric control - Second order conditions - Differential homotopy - Ordinary differential equations

FUNCTIONAL DESCRIPTION

Hampath is an open-source software developed to solve optimal control problems by coupling shooting and homotopy methods. More generally, it can be used to solve general Hamiltonian boundary value problems. It also implements an efficient computation of Jacobi fields (allowing in particular second order optimality condition checks) based on the repeated use of automatic differentiation.

- Participants: Jean-Baptiste Caillau, Olivier Cots and Joseph Gergaud
- Contact: Oliver Cots
- URL: <http://www.hampath.org>

## **MORPHEME Project-Team**

### **4. New Software and Platforms**

#### **4.1. SPADE: Small Particle DEtection**

FUNCTIONAL DESCRIPTION SPADE is an algorithm primarily designed to detect objects whose size is smaller than a few pixels (particles) on fluorescence microscopy images. It is a simplified version of a marked point process based on a shape dictionary.

- Participants: N. Cedilnik, E. Debreuve, and X. Descombes
- Contact: Xavier Descombes

## NACHOS Project-Team

# 5. New Software and Platforms

## 5.1. DIOGENeS

Discontinuous Galerkin Nanoscale Solvers

KEYWORDS: High-Performance Computing - Computational electromagnetics - Discontinuous Galerkin - Computational nanophotonics

FUNCTIONAL DESCRIPTION

DIOGENeS is a software suite dedicated to the numerical modeling of light interaction with nanometer scale structures with applications to nanophotonics and nanoplasmonics. DIOGENeS relies on a two layer architecture. The core of the suite is a library of generic software components (data structures and algorithms) for the implementation of high order DG (Discontinuous Galerkin) and HDG (Hybridizable Discontinuous Galerkin) schemes formulated on unstructured tetrahedral and hybrid structured/unstructured (cubic/tetrahedral) meshes. This library is used to develop dedicated simulation software for time-domain and frequency-domain problems relevant to nanophotonics and nanoplasmonics, considering various material models.

- Contact: Stéphane Lanteri
- URL: <http://www-sop.inria.fr/nachos/index.php/Software/DIOGENeS>

## 5.2. GERShWIN

discontinuous Galerkin Solver for microWave Interaction with biological tissues

KEYWORDS: High-Performance Computing - Computational electromagnetics - Discontinuous Galerkin - Computational bioelectromagnetics

FUNCTIONAL DESCRIPTION

GERShWIN is based on a high order DG method formulated on unstructured tetrahedral meshes for solving the 3D system of time-domain Maxwell equations coupled to a Debye dispersion model.

- Contact: Stéphane Lanteri
- URL: <http://www-sop.inria.fr/nachos/index.php/Software/GERShWIN>

## 5.3. HORSE

High Order solver for Radar cross Section Evaluation

KEYWORDS: High-Performance Computing - Computational electromagnetics - Discontinuous Galerkin

FUNCTIONAL DESCRIPTION

HORSE is based on a high order HDG (Hybridizable Discontinuous Galerkin) method formulated on unstructured tetrahedral and hybrid structured/unstructured (cubic/tetrahedral) meshes for the discretization of the 3D system of frequency-domain Maxwell equations, coupled to domain decomposition solvers.

- Contact: Stéphane Lanteri
- URL: <http://www-sop.inria.fr/nachos/index.php/Software/HORSE>

## STARS Project-Team

# 5. New Software and Platforms

## 5.1. CLEM

### FUNCTIONAL DESCRIPTION

The Clem Toolkit is a set of tools devoted to design, simulate, verify and generate code for LE programs. LE is a synchronous language supporting a modular compilation. It also supports automata possibly designed with a dedicated graphical editor and implicit Mealy machine definition.

- Participants: Daniel Gaffe and Annie Ressouche
- Contact: Annie Ressouche
- URL: <http://www-sop.inria.fr/teams/pulsar/projects/Clem/>

## 5.2. EGMM-BGS

### FUNCTIONAL DESCRIPTION

This software implements a generic background subtraction algorithm for video and RGB-D cameras, which can take feedback from people detection and tracking processes. Embedded in a people detection framework, it does not classify foreground / background at pixel level but provides useful information for the framework to remove noise. Noise is only removed when the framework has all the information from background subtraction, classification and object tracking. In our experiment, our background subtraction algorithm outperforms GMM, a popular background subtraction algorithm, in detecting people and removing noise.

- Participants: Anh Tuan Nghiem, Francois Bremond and Vasanth Bathrinarayanan
- Contact: Francois Bremond

## 5.3. MTS

### FUNCTIONAL DESCRIPTION

This software consists of a retrieval tool for a human operator to select a person of interest in a network of cameras. The multi-camera system can re-identify the person of interest, wherever and whenever (s)he has been observed in the camera network. This task is particularly hard due to camera variations, different lighting conditions, different color responses and different camera viewpoints. Moreover, we focus on non-rigid objects (i.e. humans) that change their pose and orientation contributing to the complexity of the problem. In this work we design two methods for appearance matching across non-overlapping cameras. One particular aspect is the choice of the image descriptor. A good descriptor should capture the most distinguishing characteristics of an appearance, while being invariant to camera changes. We chose to describe the object appearance by using the covariance descriptor as its performance is found to be superior to other methods. By averaging descriptors on a Riemannian manifold, we incorporate information from multiple images. This produces mean Riemannian covariance that yields a compact and robust representation. This new software has made digital video surveillance systems a product highly asked by security operators, especially the ones monitoring large critical infrastructures, such as public transportation (subways, airports, and harbours), industrials (gas plants), and supermarkets.

- Participants: Slawomir Bak and Francois Bremond
- Contact: Francois Bremond

## 5.4. Person Manual Tracking in a Static Camera Network (PMT-SCN)

### FUNCTIONAL DESCRIPTION

This software allows tracking a person in a heterogeneous camera network. The tracking is done manually. The advantage of this software is to give the opportunity to operators in video-surveillance to focus on tracking the activity of a person without knowing the positions of the cameras in a considered area. When the tracked person leaves the field-of-view (FOV) of a first camera, and enters the FOV of a second one, the second camera is automatically showed to the operator. This software was developed conjointly by Inria and Neosensys.

- Participants: Bernard Boulay, Anais Ducoffe, Sofia Zaidenberg, Annunziato Polimeni and Julien Gueytat
- Partner: Neosensys
- Contact: Anais Ducoffe

## 5.5. PrintFoot Tracker

### FUNCTIONAL DESCRIPTION

This software implements a new algorithm for tracking multiple persons in a single camera. This algorithm computes many different appearance-based descriptors to characterize the visual appearance of an object and to track it over time. Object tracking quality usually depends on video scene conditions (e.g. illumination, density of objects, object occlusion level). In order to overcome this limitation, this algorithm presents a new control approach to adapt the object tracking process to the scene condition variations. More precisely, this approach learns how to tune the tracker parameters to cope with the tracking context variations. The tracking context, or video context, of a video sequence is defined as a set of six features: density of mobile objects, their occlusion level, their contrast with regard to the surrounding background, their contrast variance, their 2D area and their 2D area variance. The software has been experimented with three different tracking algorithms and on long, complex video datasets.

- Participants: Duc Phu Chau and Francois Bremond
- Contact: Francois Bremond

## 5.6. Proof Of Concept Néosensys (Poc-NS)

### FUNCTIONAL DESCRIPTION

This is a demonstration software which gathers different technologies from Inria and Neosensys: PMT-SCN, re-identification and auto-side switch. This software is used to approach potential clients of Neosensys.

- Participants: Bernard Boulay, Sofia Zaidenberg, Julien Gueytat, Slawomir Bak, Francois Bremond, Annunziato Polimeni and Yves Pichon
- Partner: Neosensys
- Contact: Francois Bremond

## 5.7. SUP

Scene Understanding Platform

KEYWORDS: Activity recognition - 3D - Dynamic scene

### FUNCTIONAL DESCRIPTION

SUP is a software platform for perceiving, analyzing and interpreting a 3D dynamic scene observed through a network of sensors. It encompasses algorithms allowing for the modeling of interesting activities for users to enable their recognition in real-world applications requiring high-throughput.

- Participants: François Brémond, Carlos Fernando Crispim Junior and Etienne Corvée
- Partners: CEA - CHU Nice - I2R - Université de Hamburg - USC Californie
- Contact: Francois Bremond
- URL: <https://team.inria.fr/stars/software>

## 5.8. VISEVAL

### FUNCTIONAL DESCRIPTION

ViSEval is a software dedicated to the evaluation and visualization of video processing algorithm outputs. The evaluation of video processing algorithm results is an important step in video analysis research. In video processing, we identify 4 different tasks to evaluate: detection, classification and tracking of physical objects of interest and event recognition.

- Participants: Bernard Boulay and Francois Bremond
- Contact: Francois Bremond
- URL: [http://www-sop.inria.fr/teams/pulsar/EvaluationTool/ViSEvAl\\_Description.html](http://www-sop.inria.fr/teams/pulsar/EvaluationTool/ViSEvAl_Description.html)

## 5.9. py\_ad

py action detection

### FUNCTIONAL DESCRIPTION

Action Detection framework Allows user to detect action in video stream. It uses model trained in py\_ar.

- Participants: Michal Koperski and Francois Bremond
- Contact: Michal Koperski

## 5.10. py\_ar

py action recognition

### FUNCTIONAL DESCRIPTION

Action Recognition training/evaluation framework. It allows user do define action recognition experiment (on clipped videos). Train, test model, save the results and print the statistics.

- Participants: Michal Koperski and Francois Bremond
- Contact: Michal Koperski

## 5.11. py\_sup\_reader

### FUNCTIONAL DESCRIPTION

This is a library which allows to read video saved in SUP format in Python.

- Participant: Michal Koperski
- Contact: Michal Koperski

## 5.12. py\_tra3d

py trajectories 3d

### SCIENTIFIC DESCRIPTION

New video descriptor which fuse trajectory information with 3D information from depth sensor.

### FUNCTIONAL DESCRIPTION

3D Trajectories descriptor Compute 3D trajectories descriptor proposed in (<http://hal.inria.fr/docs/01/05/49/49/PDF/koperski-icip.pdf>)

- Participants: Michal Koperski and Francois Bremond
- Contact: Michal Koperski

## 5.13. sup\_ad

sup action detection

**SCIENTIFIC DESCRIPTION**

This software introduces the framework for online/real-time action recognition using state-of-the-art features and sliding window technique.

**FUNCTIONAL DESCRIPTION**

SUP Action Detection Plugin Plugin for SUP platform which performs action detection using sliding window and Bag of Words. It uses an input data model trained in py\_ar project.

- Participants: Michal Koperski and Francois Bremond
- Contact: Michal Koperski

## TITANE Project-Team

# 6. New Software and Platforms

## 6.1. CGAL Barycentric\_coordinates\_2

This CGAL software component offers an efficient and robust implementation of two-dimensional closed-form generalized barycentric coordinates defined for simple two-dimensional polygons.

- Participants: Pierre Alliez
- Contact: Pierre Alliez
- URL: [http://doc.cgal.org/latest/Barycentric\\_coordinates\\_2/index.html#Chapter\\_2D\\_Generalized\\_Barycentric\\_Coordinates](http://doc.cgal.org/latest/Barycentric_coordinates_2/index.html#Chapter_2D_Generalized_Barycentric_Coordinates)

## 6.2. MeshMantics

This software component implements an approach that reconstructs 3D urban scenes in the form of levels of detail (LODs). Starting from raw data sets such as surface meshes generated by multi-view stereo systems, the algorithm proceeds in three main steps: classification, abstraction and reconstruction. From geometric attributes and a set of semantic rules combined with a Markov random field, we classify the scene into four meaningful classes. The abstraction step detects and regularizes planar structures on buildings, fits icons on trees, roofs and facades, and performs filtering and simplification for LOD generation. The abstracted data are then provided as input to the reconstruction step which generates watertight buildings through a min-cut formulation on a set of 3D arrangements.

- Participants: Florent Lafarge and Pierre Alliez
- Contact: Pierre Alliez
- URL: <https://bil.inria.fr>

## 6.3. Module CGAL : Point Set Processing

This CGAL component implements methods to analyze and process unorganized point sets. The input is an unorganized point set, possibly with normal attributes (unoriented or oriented). The point set can be analyzed to measure its average spacing, and processed through functions devoted to the simplification, outlier removal, smoothing, normal estimation, normal orientation and feature edges estimation.

- Participants: Pierre Alliez and Clément Jamin
- Contact: Pierre Alliez
- URL: [http://doc.cgal.org/latest/Point\\_set\\_processing\\_3/index.html#Chapter\\_Point\\_Set\\_Processing](http://doc.cgal.org/latest/Point_set_processing_3/index.html#Chapter_Point_Set_Processing)

## 6.4. Module CGAL : Scale space surface reconstruction

This method allows to reconstruct a surface that interpolates a set of 3D points. This method provides an efficient alternative to the Poisson surface reconstruction method. The main difference in output is that this method reconstructs a surface that interpolates the point set (as opposed to approximating the point set). How the surface connects the points depends on a scale variable, which can be estimated semi-automatically.

- Participants: Pierre Alliez
- Contact: Pierre Alliez
- URL: [http://doc.cgal.org/latest/Scale\\_space\\_reconstruction\\_3/index.html#Chapter\\_Scale\\_space\\_reconstruction](http://doc.cgal.org/latest/Scale_space_reconstruction_3/index.html#Chapter_Scale_space_reconstruction)



## 6.5. Skeleton-Blockers

Skeleton-Blockers is a compact, efficient and generic data-structure that can represent any simplicial complex. The implementation is in C++11.

- Participant: David Salinas
- Contact: David Salinas
- URL: <https://project.inria.fr/gudhi/software/>

## 6.6. APP Deposits

WALLEMME is a software for classifying large-scale urban areas from dense textured 3D meshes in a supervised manner.

- Participants: Mohammad Rouhani, Florent Lafarge and Pierre Alliez.

DIMUVIC is a software for reconstructing in 3D a polyline-sketch using contextual knowledge contained in multiview stereo images.

- Participants: Jean-Dominique Favreau, Florent Lafarge and Adrien Bousseau.

ROOFEXTRACTOR is a software for reconstructing roofs from dense defect-laden meshes as compact piecewise-planar surface representations.

- Participants: Sven Oesau and Florent Lafarge.

## TOSCA Project-Team

# 5. New Software and Platforms

## 5.1. AGH

### FUNCTIONAL DESCRIPTION

AGH (for Analysis of Galton-Watson Harris paths) is a Matlab toolbox providing methods for statistical analysis of ordered trees from their Harris paths in a user-friendly environment. More precisely it allows to easily compute estimators of the relative scale of trees which share the same shape. These estimators have been introduced for Galton-Watson trees conditioned on their number of nodes but may be computed for any ordered tree.

- Participants: Romain Azaïs, Alexandre Genadot, Benoît Henry
- Contact: Benoît Henry
- URL: <http://agh.gforge.inria.fr/>

## 5.2. ExitBM

### FUNCTIONAL DESCRIPTION

The exitbm library provides methods to simulate random variables related to the first exit time and position of the Brownian motion from simple domains, namely intervals, squares and rectangles.

- Participants: Madalina Deaconu and Antoine Lejay
- Contact: Antoine Lejay
- URL: <http://exitbm.gforge.inria.fr/>

## 5.3. SDM-WindPoS

### Stochastic Downscaling Method and Wind Power Simulation

#### FUNCTIONAL DESCRIPTION

The computation of the wind at small scale and the estimation of its uncertainties is of particular importance for applications such as wind energy resource estimation. To this aim, we have developed a computer code belonging to the family of codes of atmospheric flow calculation, in the atmospheric boundary layer. SDM-windpos especially concerns the simulation of wind at small space scales (meaning that the horizontal resolution is one kilometer or less), based on the combination of an existing Numerical Weather Prediction model providing a coarse prediction, and a Lagrangian Stochastic Model for turbulent flows.

The ability of SDM-WindPoS to regamma the wind computation in the horizontal scale but also in the vertical scale is of particular interest for wind farm power production assessment. WindPoS couples direct actuator disk approach and SDM Atmospheric Boundary Layer (ABL) model for wind farm simulation.

This year we start to introduce more accurate ABL convection models in SDM. Moreover, we start to add the possibility to introduce more accurate topography when SDM is running with some coarse scale atmospheric input data. Our dedicated GUI was also improved (better rendering for the 2D and 3D views).

- Participants: Mireille Bossy
- Contact: Mireille Bossy
- URL: <http://windpos.inria.fr>

## VIRTUAL PLANTS Project-Team

### 5. New Software and Platforms

#### 5.1. OpenAleaLab

KEYWORDS: Bioinformatics - Biology - Workflow - Modelling Environment

FUNCTIONAL DESCRIPTION

OpenAleaLab is an integrated modelling environment (IME) designed for scientists based on IPython and on OpenAlea components. This open source environment is extensible via plug-ins and allows user to work with a set of diverse modelling paradigms like imperative languages (Python, R), scientific workflows (visual programming) or rule-based language (L-System). This IME, built using PyQt, provides an IPython shell, a text editor, a project manager, a graphical package installer and a world, containing the objects and state variables shared by the different paradigms. The world can be graphically interpreted in 3D or 2D. Different paradigms and tools for plant modelling are available as plug-ins, such as a visual programming environment, a L-system language, a 3D viewer, and an R editor and interpreter. The plug-in system is based on setuptools entry-points and provide both functional and GUI components. This environment is designed to be easily extensible in order to include new plant modelling paradigms in the future or to be customized for other scientific domains. Several dedicated extensions (TissueLab, PlantLab) have been developed or are in development.

- Participants: Christophe Pradal, Christophe Godin.
- Contact: Christophe Pradal, Christophe Godin
- URL: <http://virtualplants.github.io/>

#### 5.2. TissueLab

KEYWORDS: Bioinformatics - Biology - Modelling Environment

FUNCTIONAL DESCRIPTION

TissueLab is an OpenAleaLab extension dedicated to study plant morphogenesis at the scale of the tissues. This extension was built on the basis of several key concepts of OpenAleaLab (project, world, interactive panels, etc.) and using its plugin mechanism (dynamically discovered, modular, extensible, etc.). TissueLab provides a framework for the visualization, exploration, interaction, reconstruction, analysis and simulation of tissue development based on image sequences. It contains for instance the PyThor module, dedicated to 3D real-time interaction and modification of segmented images for the creation of ground truth segmentations.

- Participants: Sophie Ribes, Guillaume Baty, Guillaume Cerutti, Alizon Konig, Grégoire Malandain, Christophe Pradal, Christophe Godin.
- Contact: Christophe Godin
- URL: <https://github.com/virtualplants/tissuelab>

#### 5.3. Draco-Stem

KEYWORDS: 3D Reconstruction - Triangular Mesh - Biomechanical Simulations

FUNCTIONAL DESCRIPTION

A computational tool called DRACO-STEM (Dual Reconstruction by Adjacency Complex Optimization - SAM Tissue Enhanced Mesh) has been made available, with the aim of bridging the gap between experimental data and tissue biomechanics models. It provides the necessary tools to generate a FEM-ready, topologically accurate, complete 3D triangular mesh of meristematic tissue, based on a segmented image obtained from a confocal microscopy acquisition. The produced meshes proved to be useable as an input for computational simulations of biomechanical and physiological cellular processes.

- Participants: Guillaume Cerutti, Christophe Godin, Olivier Ali
- Contact: Guillaume Cerutti
- URL: [https://github.com/VirtualPlants/draco\\_stem/](https://github.com/VirtualPlants/draco_stem/)

## 5.4. ASTEC

KEYWORDS: Segmentation - Tracking - High resolution

FUNCTIONAL DESCRIPTION

A new algorithmic pipeline, ASTEC (Adaptative Segmentation and Tracking of Embryonic Cells), has been developed to segment and track cell shapes in 3D from movies with high spatio-temporal resolution of embryos where the membranes have been labeled (using dye or genetic markers for example). To segment the 3D embryo image at a given time-point, ASTEC takes advantage of the high spatial resolution of the movie in order to propagate the segmentation of the previous time points. This, coupled to biological knowledge on the studied system, allows to constrain the segmentation and to track cells throughout time simultaneously. Moreover, the propagation allows to bound the potential mistakes of segmentation (e.g. a cells cannot disappear) which enables powerful post-correction based on the study of the resulting tracking.

- Participants: Léo Guignard, Emmanuel Faure, Grégoire Malandain, Patrick Lemaire, Christophe Godin
- Contact: Christophe Godin
- URL: <https://gforge.inria.fr/projects/marsalt/>

## 5.5. AutoWIG

KEYWORDS: Syntactic Analysis

FUNCTIONAL DESCRIPTION

High-level programming languages, such as Python and R, are popular among scientists. They are concise, readable, lead to rapid development cycles, but suffer from performance drawback compared to compiled languages. However, these languages allow to interface C, C++ and Fortran code. In this way, most of the scientific packages incorporate compiled scientific libraries to both speed up the code and reuse legacy libraries. While several semi-automatic solutions and tools exist to wrap these compiled libraries, the process of wrapping a large library is cumbersome and time consuming. We developed AutoWIG [40], [47], a Python library that wraps automatically compiled libraries into high-level languages. Our approach consists in parsing C++ code using the LLVM/Clang technologies and generating the wrappers using the Mako templating engine. Our approach is automatic, extensible, and applies to very complex C++ libraries, composed of thousands of classes or incorporating modern meta-programming constructs. The usage and extension of AutoWIG have been illustrated on a set of statistical libraries (StructureAnalysis).

- Participants: Pierre Fernique, Christophe Pradal
- Contact: Pierre Fernique
- URL: <https://github.com/VirtualPlants/AutoWIG>

## 5.6. Phenomenal

KEYWORDS: Image Analysis, Phenotyping

FUNCTIONAL DESCRIPTION

Phenomenal [65] is a Python library dedicated to the analysis of high throughput phenotyping data and models. It has been developed in the frame of the Phenome high throughput phenotyping infrastructure. It is based on the OpenAlea platform [76], [77] that provides methods and softwares for the modelling of plants, together with a user-friendly interface for the design and execution of scientific workflows. OpenAlea is also part of the InfraPhenoGrid infrastructure that allows high throughput computation and recording of provenance during the execution [26].

- Participants: Simon Artzet, Jérôme Chopard, Tsu-Wei Chen, Nicolas Brichet, Christian Fournier, Christophe Pradal
- Contact: Christian Fournier, Christophe Pradal
- URL: <https://gitlab.inria.fr/phenome/phenomenal>

## 5.7. Platforms

### 5.7.1. Platform OpenAlea

*OpenAlea* is an open-software platform for interdisciplinary research in plant modeling and simulation. This scientific workflow platform is used for the integration and comparison of different models and tools provided by the research community. It is based on the Python (<http://www.python.org>) language that aims at being both a *glue* language for the different modules and an efficient modeling language for developing new models and tools. *OpenAlea* currently includes modules for plant simulation, analysis and modeling at different scales (*V-Plants* modules), for modeling ecophysiological processes (*Alinea* modules) such as radiative transfer, transpiration and photosynthesis (*RATP*, *Caribu*, *Adel*, *TopVine*, *Ecomeristem*) and for 3D visualization of plant architecture at different scales (*PlantGL*).

*OpenAlea* is the result of a collaborative effort associating 20 french research teams in plant modeling from Inria, CIRAD, INRA and ENS Lyon. The Virtual Plants team coordinates both development and modeling consortia, and is more particularly in charge of the development of the kernel and of some of the main data structures such as multi-scale tree graphs and statistical sequences.

*OpenAlea* is a fundamental tool to share models and methods in interdisciplinary research (comprising botany, ecophysiology, forestry, agronomy, applied mathematics and computer science approaches). Embedded in Python and its scientific libraries, the platform may be used as a flexible and useful toolbox by biologists and modelers for various purposes (research, teaching, rapid model prototyping, communication, etc.).

New methodological developments around scientific workflows in *OpenAlea* have been done recently.

### 5.7.2. Platform Sofa

Our team is increasingly using the platform SOFA developed at Inria by other teams, in conjunction with OpenAlea, to model biomechanics of plant tissues. SOFA (<https://www.sofa-framework.org>) is an Open Source framework primarily targeted at real-time simulation, with an emphasis on biological simulation. It is mostly intended for the research community to help develop new algorithms, but can also be used as an efficient prototyping tool. Based on an advanced software architecture, it allows the creation of complex and evolving simulations by combining new algorithms with algorithms already included in SOFA, the modification of most parameters of the simulation (deformable behavior, surface representation, solver, constraints, collision algorithm, etc. ) by simply editing an XML file, the building of complex models from simpler ones using a scene-graph description, the efficient simulation of the dynamics of interacting objects using abstract equation solvers, the reuse and easy comparison of a variety of available methods. It has been extensively used by our team in the recent years to conduct virtual mechanical experiments on plant tissues (see section 6.2.3 ).

## WIMMICS Project-Team

# 6. New Software and Platforms

## 6.1. Corese

COncceptual REsource Search Engine

KEYWORDS: Semantic Web - Web of Data - Search Engine - RDF - SPARQL

FUNCTIONAL DESCRIPTION

Corese is a Semantic Web Factory that implements W3C RDF, RDFS, SPARQL 1.1 Query and Update. Furthermore, Corese query language integrates original features such as approximate search. It provides a SPARQL Template Transformation Language for RDF, a SPARQL based Inference Rule Language for RDF and a Linked Data Script Language. Corese also provides distributed federated query processing, a Semantic Web server and a SPARQL endpoint. Corese development is supported by an Inria grant (ADT).

- Participants: Olivier Corby, Erwan Demairy, Catherine Faron-Zucker, Fabien Gandon. Alumni: Virginie Bottollier, Olivier Savoie, and Fuqi Song.
- Partners: I3S - Mnemotix
- Contact: Olivier Corby
- URL: <http://wimmics.inria.fr/corese>, <http://corese.inria.fr>

## 6.2. DBpedia.fr

FUNCTIONAL DESCRIPTION

DBpedia is an international crowd-sourced community effort to extract structured information from Wikipedia and make this information available on the Semantic Web as Linked Open Data. The DBpedia triple stores allow anyone to solve sophisticated queries against Wikipedia extracted data, and to link the different data sets on these data. The French chapter of DBpedia was created and deployed by Wimmics and is now an online running platform providing data to several projects such as: QAKIS, Izipedia, zone47, Sépage, HdA Lab, JocondeLab, etc. In addition, Wimmics extended the open source DBpedia platform with new capabilities and in particular DBpedia Historic to extract the entire edition history of a chapter as linked data.

- Participants: Fabien Gandon and Raphaël Boyer
- Contact: Fabien Gandon
- URL: <http://dbpedia.fr>

## 6.3. Discovery Hub

Discovery Hub Exploratory Search Engine

KEYWORD: Search Engine

FUNCTIONAL DESCRIPTION

Discovery Hub is an exploratory search engine built on top of linked data sources and, in particular, DBpedia. The exploratory search is a new way to search the web to find new topics the users were not aware of but which may be interesting for them. It allows users performing queries in an innovative way and helps them navigate rich results. As a hub, it proposes redirections to others platforms to let users benefit from their discoveries. It relies on an extension of spreading activation algorithms over linked data to recommend and explain results.

- Participants: Nicolas Marie, Fabien Gandon, Emilie Palagi and Alain Giboin
- Partner: Alcatel-Lucent
- Contact: Fabien Gandon
- URL: <http://discoveryhub.co/>

## 6.4. Licentia

License you Data

KEYWORDS: Licenses - Normative Reasoning - Semantic Web - RDF

FUNCTIONAL DESCRIPTION

Licentia is a web service application with the aim to support users in licensing data. Our goal is to provide a full suite of services to help in the process of choosing the most suitable license depending on the data to be licensed. The core technology used in our services is powered by the SPINdle Reasoner and the use of Defeasible Deontic Logic to reason over the licenses and conditions. The dataset of RDF licenses we use in Licentia is the RDF licenses dataset where the Creative Commons Vocabulary and Open Digital Rights Language (ODRL) Ontology are used to express the licenses.

- Participants: Serena Villata, Fabien Gandon. Alumni: Cristian Cardellino
- Partners: I3S
- Contact: Serena Villata
- URL: <http://licentia.inria.fr/>

## 6.5. Qakis

Question-Answering wiki framework based system

FUNCTIONAL DESCRIPTION

The QAKiS system (figure 2 ) implements question answering over DBpedia. QAKiS allows end users to submit a query to an RDF triple store in English and obtain the answer in the same language, hiding the complexity of the non-intuitive formal query languages involved in the resolution process. At the same time, the expressiveness of these standards is exploited to scale to the huge amounts of available semantic data. Its major novelty is to implement a relation-based match for question interpretation, to convert the user question into a query language (e.g. SPARQL). English, French and German DBpedia chapters are the RDF data sets to be queried using a natural language interface.

- Participants: Elena Cabrio, Julien Cojan, Amine Hallili, Alessio Palmero Aprosio, Fabien Gandon and Serena Villata.
- Contact: Elena Cabrio
- URL: <http://www.qakis.org/>

## 6.6. KNEWS

Versatile Text-to-Knowledge Pipeline

KEYWORD: NLP

FUNCTIONAL DESCRIPTION

KNEWS is a versatile text-to-knowledge pipeline for machine reading, configurable to use different external modules for word sense disambiguation and entity linking. KNEWS works by running these components separately on a text, then it aligns the output of a semantic parser (Boxer) to the output of the other two modules, to produce complete semantic structures linked to DBpedia and Wordnet and represented as RDF graphs. KNEWS provides different kind of outputs: frame instances (based on the FrameBase scheme), word-aligned frames, and first-order logic formulas.

- Participants: Valerio Basile, Elena Cabrio and Fabien Gandon.
- Contact: Valerio Basile & Elena Cabrio
- URL: <https://github.com/valeribasile/learningbyreading>

## ZENITH Project-Team

# 6. New Software and Platforms

## 6.1. Pl@ntNet

**Participants:** Antoine Affouard, Jean-Christophe Lombardo, Hervé Goëau, Alexis Joly [contact].

Pl@ntNet is an image sharing and retrieval application for the identification of plants. It is developed in the context of the Floris'tic project that involves Inria, CIRAD, INRA, IRD and Tela Botanica. The key feature of the iOS and Android front ends is to help identifying plant species from photographs, through a server-side visual search engine. Since its first release in march 2013 on the apple store, the application has been downloaded by 3M users in more than 170 countries, with between 15,000 and 50,000 active users daily. The collaborative training set that allows the content-based identification is continuously enriched by the users of the application and the members of Tela Botanica social network. At the time of writing, it includes about 300K images covering more than 10K species in the world (and about 60% of the West European flora).

## 6.2. The Plant Game: crowdsourced plants identification

**Participants:** Maximilien Servajean, Alexis Joly [contact], Antoine Affouard.

URL: <http://theplantgame.com/>

The Plant Game is a participatory game whose purpose is the production of large masses of taxonomic data to improve our knowledge of biodiversity. The objective is to learn botany with fun and participate to a large citizen sciences project in biodiversity. The game relies on consistent research contributions in scalable crowdsourcing models and algorithms that can deal with thousands of complex classes such as plant species. One major contribution is the active training of the users based on innovative sub-task creation and assignment processes that are adaptive to the increasing skills of the user. The first public version of the game was released in july 2015. As of today, about 22K players are registered and produce hundreds of new validated plant observations per day. The accuracy of the produced taxonomic tags is about 94%, which is quite impressive considering the fact that a majority of users are beginners when they start playing.

## 6.3. Smart'Flore

**Participants:** Antoine Affouard [contact], Alexis Joly, Hervé Goëau.

URL: <http://otmedia.lirmm.fr/>

Smart'Flore is an Android mobile application for the discovery of the surrounding vegetal biodiversity. It has three main features: (i) the geo-based exploration of the world's largest repository of biodiversity occurrences (GBIF, <http://www.gbif.org/>), (ii) the exploration of virtual botanical trails (created offline through a dedicated web application hosted by TelaBotanica NGO) and (iii) the access to a variety of information about the plants. Smart'Flore is the first mobile app in the world making use of the GBIF web services which makes it a remarkable and possibly highly visible realization. The first public version of the application was released in may 2016. Since then, it has been downloaded by more than 22K users and the daily number of sessions is about 250.

## 6.4. Snoop & SnoopIm

**Participants:** Alexis Joly, Julien Champ, Jean-Christophe Lombardo.

URL: <http://otmedia.lirmm.fr/>



Snoop is a generalist C++ library dedicated to high-dimensional data management and efficient similarity search. Its main features are dimension reduction, high-dimensional feature vector hashing, approximate k-nearest neighbors search and Hamming embedding. Snoop is a refactoring of a previous library called PMH developed jointly with INA. SnoopIm is a content-based image search engine built on top of Snoop that allows retrieving small visual patterns or objects in large collections of pictures. The software is used as the visual search engine of the PI@ntNet applications and it is used in several other contexts, including a logo retrieval application in collaboration with INA, a whale's individuals matching application in collaboration with the CetaMada NGO, and a hieroglyph recognition application in collaboration with the Egyptology department of University Montpellier 3.

## 6.5. MultiSite-Rec

**Participants:** Mohamed Reda Bouadjenek, Florent Masegla, Esther Pacitti.

Recommender systems are used as a mean to supply users with content that may be of interest to them. They have become a popular research topic, where many aspects and dimensions have been studied to make them more accurate and effective. In practice, recommender systems suffer from cold-start problems. However, users use many online services, which can provide information about their interest and the content of items (e.g. Google search engine, Facebook, Twitter, etc.). These services may be valuable data sources, which supply information to help a recommender system in modeling users and items' preferences, and thus, make the recommender system more precise. Moreover, these data sources are distributed, and geographically distant from each other, which raise many research problems and challenges to design a distributed recommendation algorithm. MultiSite-Rec is a distributed collaborative filtering algorithm, which exploits and combine these multiple and heterogeneous data sources to improve the recommendation quality.

## 6.6. Chiaroscuro

**Participants:** Tristan Allard, Florent Masegla, Esther Pacitti.

URL: <http://people.irisa.fr/Tristan.Allard/chiaroscuro/>

Chiaroscuro is a software developed in the context of a research contract with EDF. It aims at clustering time series with privacy preserving guarantees. It is a distributed system, working in a P2P environment. It is used by the team for experiments and by EDF as a proof-of-concept. Chiaroscuro is the first software for that purpose. It is written in Java. The distributed algorithm implemented in Chiaroscuro has been filed by EDF in a patent (with Inria and University of Montpellier)

## 6.7. LogMagnet

**Participant:** Florent Masegla.

URL: <https://team.inria.fr/zenith/software/LogMagnet>

LogMagnet is a software for analyzing streaming data, and in particular log data. Log data usually arrive in the form of lines containing activities of human or machines. In the case of human activities, it may be the behavior on a Web site or the usage of an application. In the case of machines, such log may contain the activities of software and hardware components (say, for each node of a computing cluster, the calls to system functions or some hardware alerts). Analyzing such data is often difficult and crucial in the meanwhile. LogMagnet allows to summarize this data, and to provide a first analysis as a clustering. This summary may also be exploited as easily as the original data.

## 6.8. FP-Hadoop

**Participants:** Reza Akbarinia, Patrick Valduriez.

<https://gforge.inria.fr/plugins/mediawiki/wiki/fp-hadoop>

FP-Hadoop is an extension of Hadoop that efficiently deals with the problem of data skew in MapReduce jobs. In FP-Hadoop, there is a new phase, called intermediate reduce (IR), in which blocks of intermediate values, constructed dynamically, are processed by intermediate reduce workers in parallel, by using a scheduling strategy.

## 6.9. CloudMdsQL Compiler

**Participants:** Carlyna Bondiombouy, Boyan Kolev, Oleksandra Levchenko, Patrick Valduriez.

URL: <http://cloudmssql.gforge.inria.fr>

The CloudMdsQL (Cloud Multi-datastore Query Language) compiler transforms queries expressed in a common SQL-like query language into an optimized query execution plan to be executed over multiple cloud data stores (SQL, NoSQL, HDFS, etc.) through a query engine. The compiler/optimizer is implemented in C++ and uses the Boost.Spirit framework for parsing context-free grammars. CloudMdsQL has been validated on relational, document and graph data stores, as well as Spark/HDF in the context of the CoherentPaaS European project.

## 6.10. AgroLD

**Participants:** Pierre Larmande, Patrick Valduriez.

URL: <http://www.agrold.org>

Agronomic Linked Data (AgroLD) is a portal to help bioinformatics and domain experts exploiting the homogenized data models towards efficiently generating research hypotheses. AgroLD is an RDF knowledge base that is designed to integrate data from various publicly available plant centric data sources and ontologies, using Web Ontology Language (OWL) and the SPARQL Query Language (SPARQL).

## 6.11. SciFloware

**Participants:** Benjamin Billet, Didier Parigot.

URL: <http://www-sop.inria.fr/members/Didier.Parigot/pmwiki/Scifloware>

SciFloware is an action of technology development (ADT Inria) with the goal of developing a middleware for the execution of scientific workflows in a distributed and parallel way. It capitalizes on our experience with SON and an innovative algebraic approach to the management of scientific workflows. SciFloware provides a development environment and a runtime environment for scientific workflows, interoperable with existing systems. We validate SciFloware with workflows for analyzing biological data provided by our partners CIRAD, INRA and IRD.